

Neural Networks

Learning the network: Part 3

11-785, Fall 2024

Lecture 5

Poll: @394

Training neural nets through Empirical Risk Minimization: Problem Setup

- Given a training set of input-output pairs $(X_1, d_1), (X_2, d_2), \dots, (X_T, d_T)$
- The divergence on the i^{th} instance is $\text{div}(Y_i, d_i)$
 - $Y_i = f(X_i; W)$
- The loss (empirical risk)

$$\text{Loss}(W) = \frac{1}{T} \sum_i \text{div}(Y_i, d_i)$$

- Minimize Loss w.r.t $\{w_{ij}^{(k)}, b_j^{(k)}\}$ using gradient descent

Notation

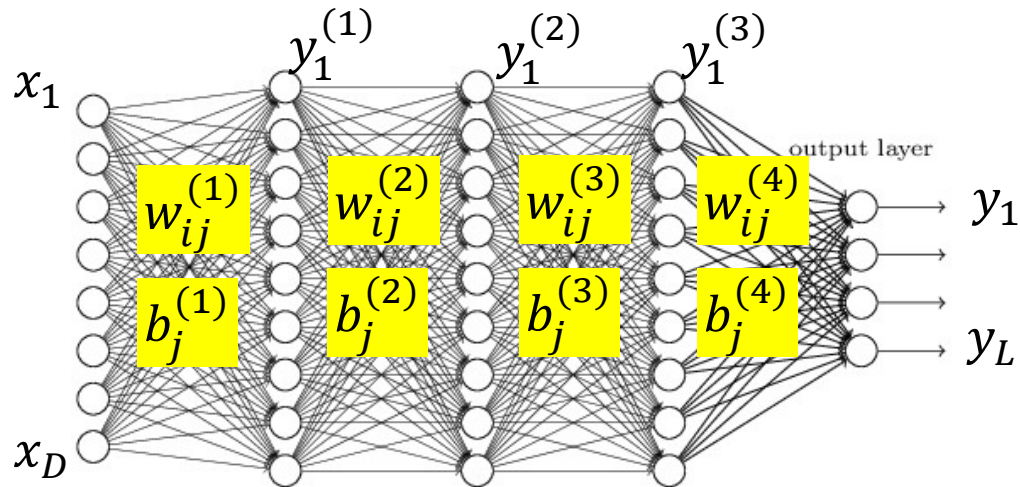

- The input layer is the 0th layer
- We will represent the output of the i -th perceptron of the k th layer as $y_i^{(k)}$
 - **Input to network:** $y_i^{(0)} = x_i$
 - **Output of network:** $y_i = y_i^{(N)}$
- We will represent the weight of the connection between the i -th unit of the $k-1$ th layer and the j th unit of the k -th layer as $w_{ij}^{(k)}$
 - The bias to the j th unit of the k -th layer is $b_j^{(k)}$

Recap: Gradient Descent Algorithm

- Initialize: To minimize any function $Loss(W)$ w.r.t W
 - W^0
 - $k = 0$
- do
 - $W^{k+1} = W^k - \eta^k \nabla Loss(W^k)^T$
 - $k = k + 1$
- while $|Loss(W^k) - Loss(W^{k-1})| > \epsilon$

Recap: Gradient Descent Algorithm

- In order to minimize $L(W)$ w.r.t. W
- Initialize:
 - W^0
 - $k = 0$

- do

- For every component i

- $W_i^{k+1} = W_i^k - \eta^k \frac{\partial L}{\partial W_i}$

Explicitly stating it by component

- $k = k + 1$

- while $|L(W^k) - L(W^{k-1})| > \varepsilon$

Training Neural Nets through Gradient Descent

Total training Loss:

$$Loss = \frac{1}{T} \sum_t Div(\mathbf{Y}_t, \mathbf{d}_t)$$

- Gradient descent algorithm:
- Initialize all weights and biases $\{w_{ij}^{(k)}\}$
 - Using the extended notation: the bias is also a weight
- Do:
 - For every layer k for all i, j , update:

$$\bullet w_{i,j}^{(k)} = w_{i,j}^{(k)} - \eta \frac{dLoss}{dw_{i,j}^{(k)}}$$

- Until *Loss* has converged

Assuming the bias is also represented as a weight

Training Neural Nets through Gradient Descent

Total training Loss:

$$Loss = \frac{1}{T} \sum_t Div(\mathbf{Y}_t, \mathbf{d}_t)$$

- Gradient descent algorithm:
- Initialize all weights and biases $\{w_{ij}^{(k)}\}$
 - Using the extended notation: the bias is also a weight
- Do:
 - For every layer k for all i, j , update:

$$\bullet w_{i,j}^{(k)} = w_{i,j}^{(k)} - \eta \frac{dLoss}{dw_{i,j}^{(k)}}$$

- Until *Loss* has converged

Assuming the bias is also represented as a weight

The derivative

Total training Loss:

$$Loss = \frac{1}{T} \sum_t Div(\mathbf{Y}_t, \mathbf{d}_t)$$

- Computing the derivative

Total derivative:

$$\frac{dLoss}{dw_{i,j}^{(k)}} = \frac{1}{T} \sum_t \frac{dDiv(\mathbf{Y}_t, \mathbf{d}_t)}{dw_{i,j}^{(k)}}$$

The derivative

Total training Loss:

$$Loss = \frac{1}{T} \sum_t Div(\mathbf{Y}_t, \mathbf{d}_t)$$

- Computing the derivative

Total derivative:

$$\frac{dLoss}{dw_{i,j}^{(k)}} = \frac{1}{T} \sum_t \frac{dDiv(\mathbf{Y}_t, \mathbf{d}_t)}{dw_{i,j}^{(k)}}$$

- So we must first figure out how to compute the derivative of divergences of individual training inputs

Calculus Refresher: Basic rules of calculus

For any differentiable function

$$y = f(x)$$

with derivative

$$\frac{dy}{dx}$$

the following must hold for sufficiently small Δx  $\Delta y \approx \frac{dy}{dx} \Delta x$

Calculus Refresher: Basic rules of calculus

For any differentiable function

$$y = f(x)$$

with derivative

$$\frac{dy}{dx}$$

the following must hold for sufficiently small Δx

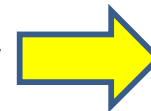

$$\Delta y \approx \frac{dy}{dx} \Delta x$$

x



y

Introducing the
"influence" diagram:
x influences y

Calculus Refresher: Basic rules of calculus

For any differentiable function

$$y = f(x)$$

with derivative

$$\frac{dy}{dx}$$

the following must hold for sufficiently small Δx

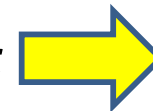

$$\Delta y \approx \frac{dy}{dx} \Delta x$$

x



y

Introducing the "influence" diagram: x influences y

Δx



Δy

$$\frac{dy}{dx}$$

$$\Delta y = \frac{dy}{dx} \Delta x$$

The derivative graph: The edge carries the derivative.

Node and edge weights multiply

Calculus Refresher: Basic rules of calculus

For any differentiable function

$$y = f(x_1, x_2, \dots, x_M)$$

What is the influence diagram relating x_1, x_2, \dots, x_M and y ?

Calculus Refresher: Basic rules of calculus

For any differentiable function

$$y = f(x_1, x_2, \dots, x_M)$$

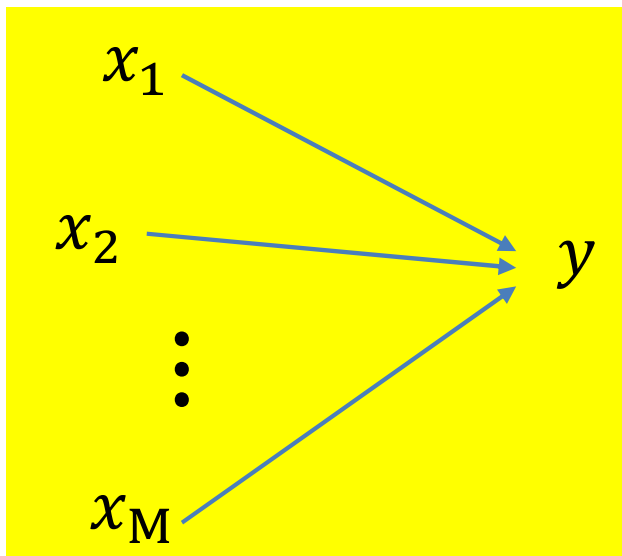

The derivative diagram?

Calculus Refresher: Basic rules of calculus

For any differentiable function

$$y = f(x_1, x_2, \dots, x_M)$$

with partial derivatives

$$\frac{\partial y}{\partial x_1}, \frac{\partial y}{\partial x_2}, \dots, \frac{\partial y}{\partial x_M}$$

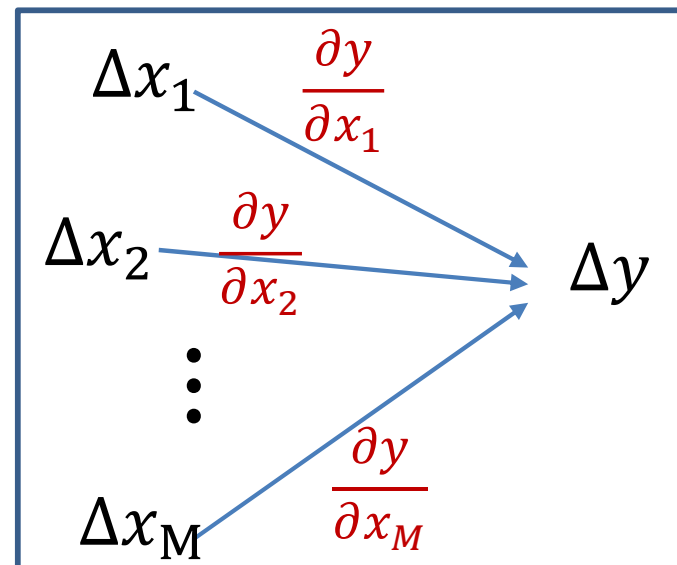
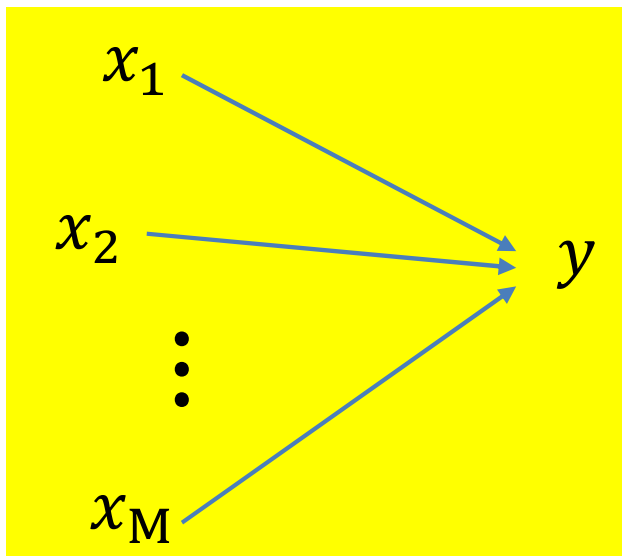

Calculus Refresher: Basic rules of calculus

For any differentiable function

$$y = f(x_1, x_2, \dots, x_M)$$

with partial derivatives

$$\frac{\partial y}{\partial x_1}, \frac{\partial y}{\partial x_2}, \dots, \frac{\partial y}{\partial x_M}$$

the following must hold for sufficiently small $\Delta x_1, \Delta x_2, \dots, \Delta x_M$

$$\Delta y \approx \frac{\partial y}{\partial x_1} \Delta x_1 + \frac{\partial y}{\partial x_2} \Delta x_2 + \dots + \frac{\partial y}{\partial x_M} \Delta x_M$$

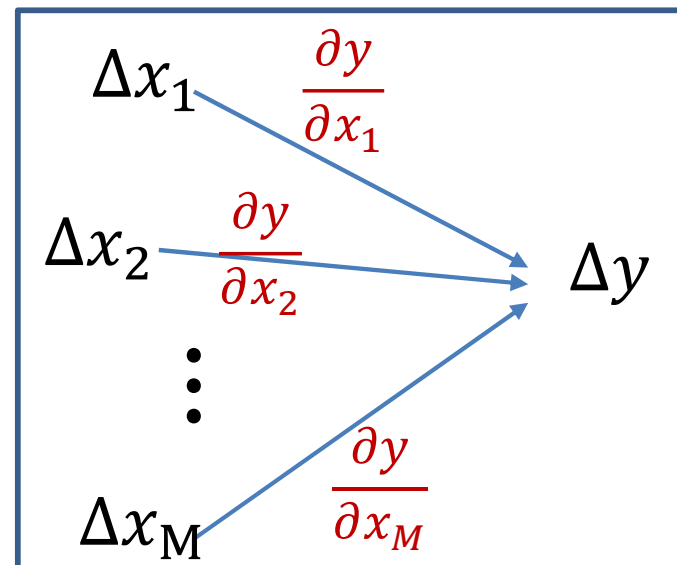
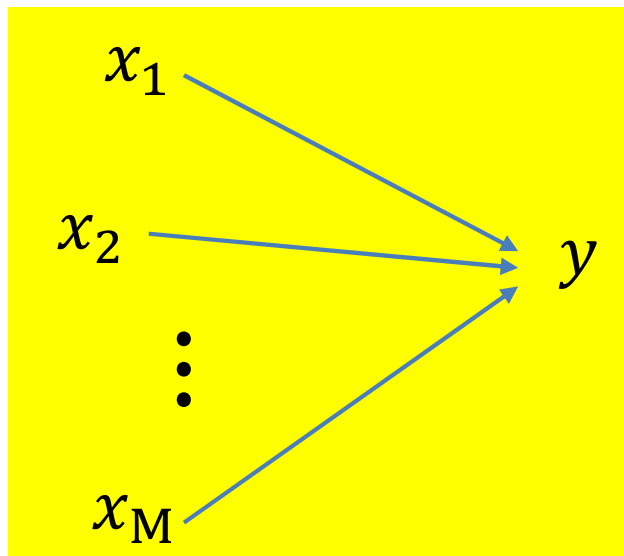

Calculus Refresher: Chain rule

For any nested function $y = f(g(x))$

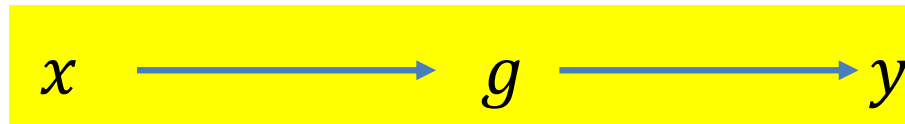

Calculus Refresher: Chain rule

For any nested function $y = f(g(x))$

$$\frac{dy}{dx} = \frac{dy}{dg(x)} \frac{dg(x)}{dx}$$

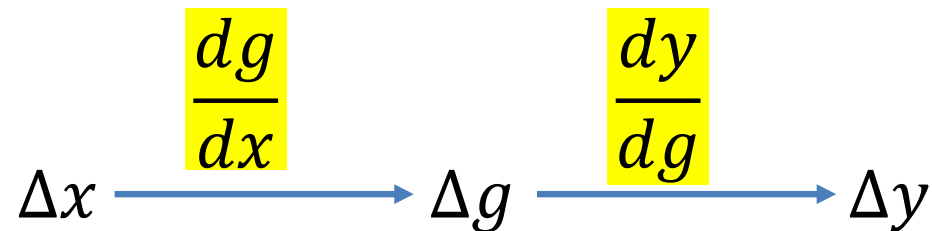
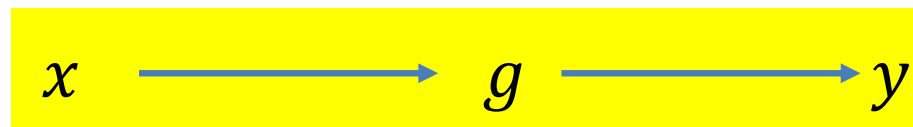

$$\Delta y = \frac{dy}{dg(x)} \frac{dg(x)}{dx} \Delta x$$

Distributed Chain Rule: Influence Diagram

$$y = f(g_1(x), g_1(x), \dots, g_M(x))$$

Shorthand: $z_i = g_i(x)$

Distributed Chain Rule: Influence Diagram

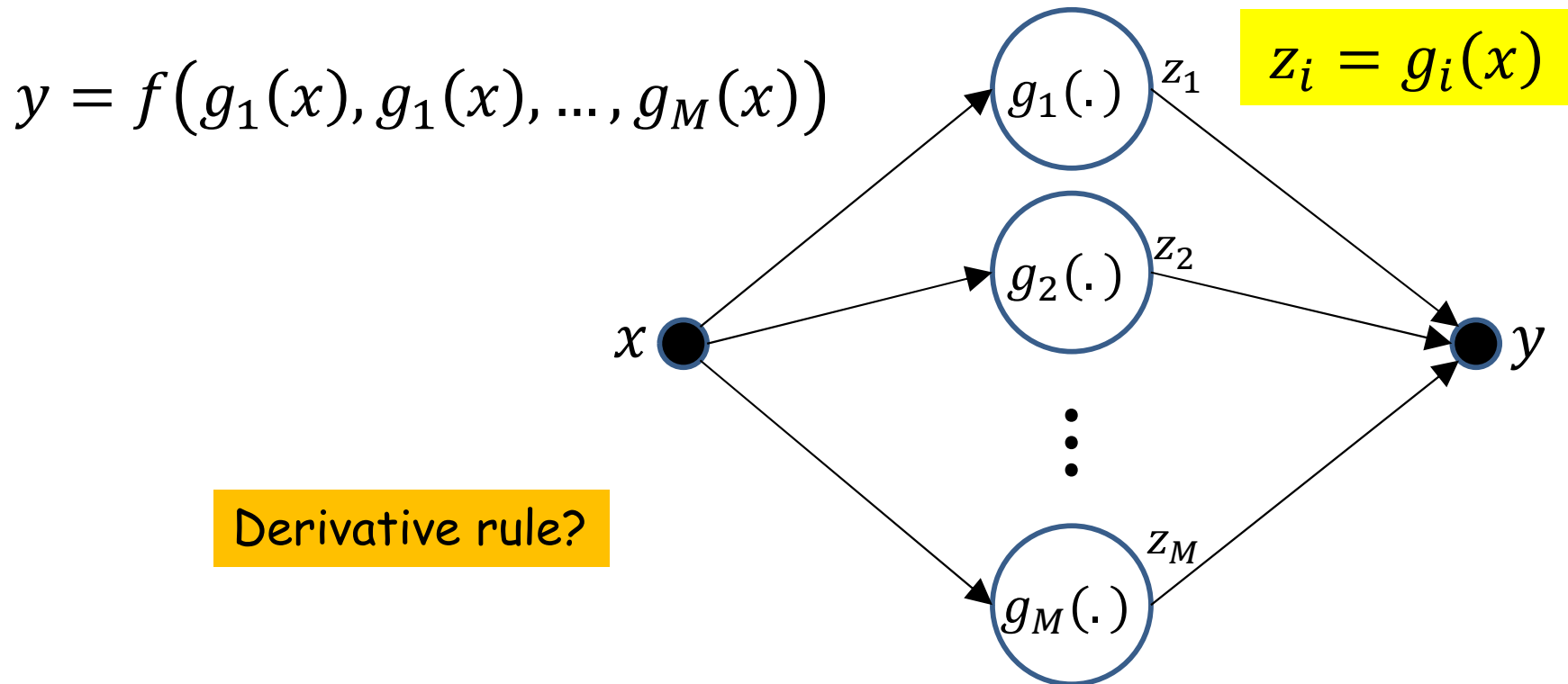

- x affects y through each of $g_1 \dots g_M$

Distributed Chain Rule: Influence Diagram

$$y = f(g_1(x), g_1(x), \dots, g_M(x))$$

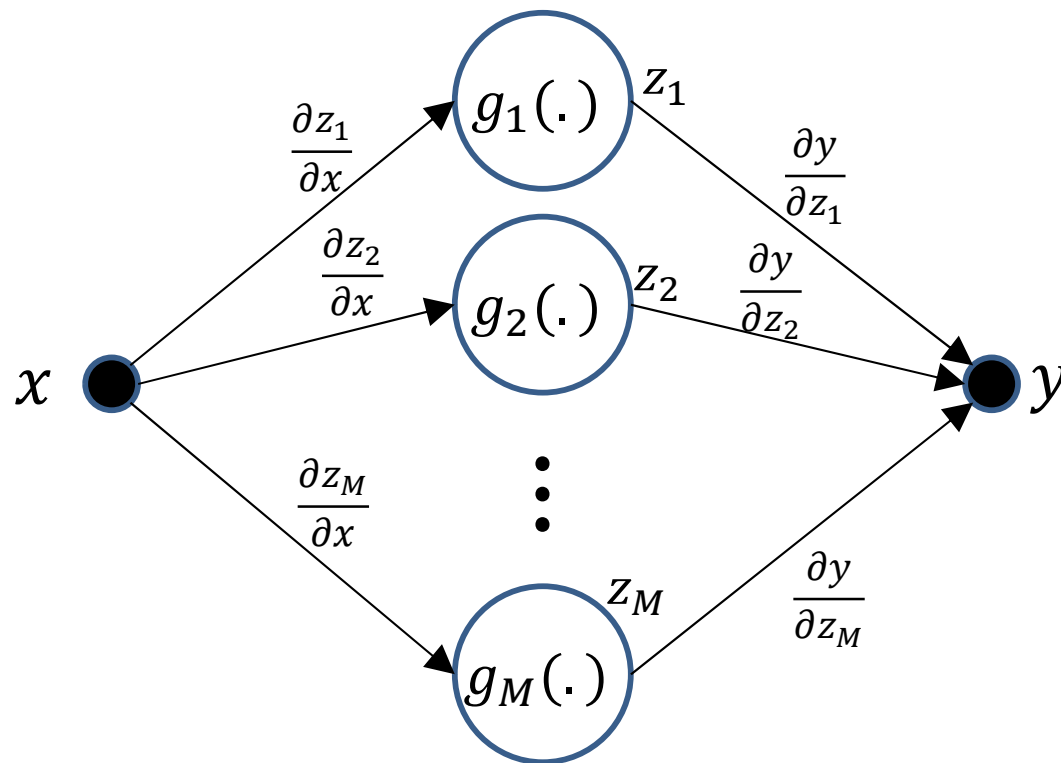

Calculus Refresher: Chain rule summary

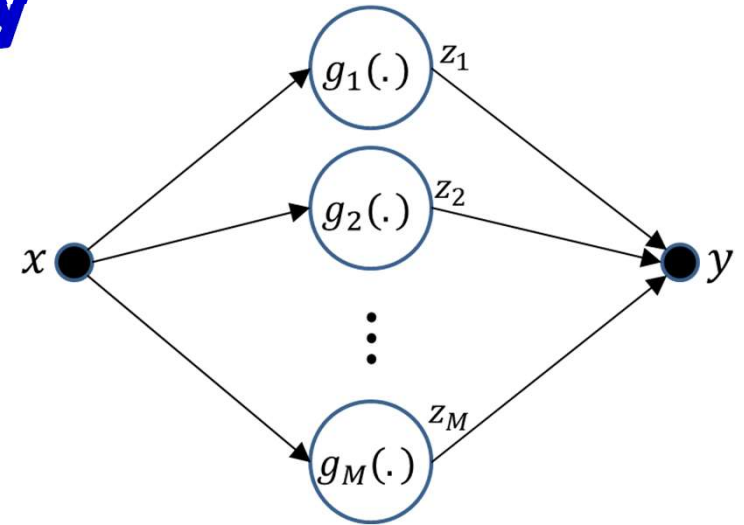

For $y = f(z_1, z_2, \dots, z_M)$
 where $z_i = g_i(x)$

$$\Delta y = \sum_i \frac{\partial y}{\partial z_i} \Delta z_i \quad \Delta z_i = \frac{dz_i}{dx} \Delta x$$

$$\frac{dy}{dx} = \frac{\partial y}{\partial z_1} \frac{dz_1}{dx} + \frac{\partial y}{\partial z_2} \frac{dz_2}{dx} + \dots + \frac{\partial y}{\partial z_M} \frac{dz_M}{dx}$$

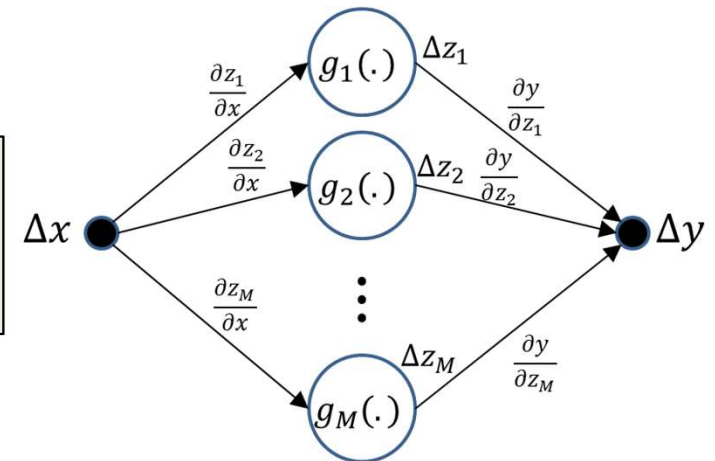

Calculus Refresher: Chain rule summary

For any nested function $l = f(y)$ where $y = g(z)$

$$\frac{dl}{dz} = \frac{dl}{dy} \frac{dy}{dz}$$

For $l = f(z_1, z_2, \dots, z_M)$
where $z_i = g_i(x)$

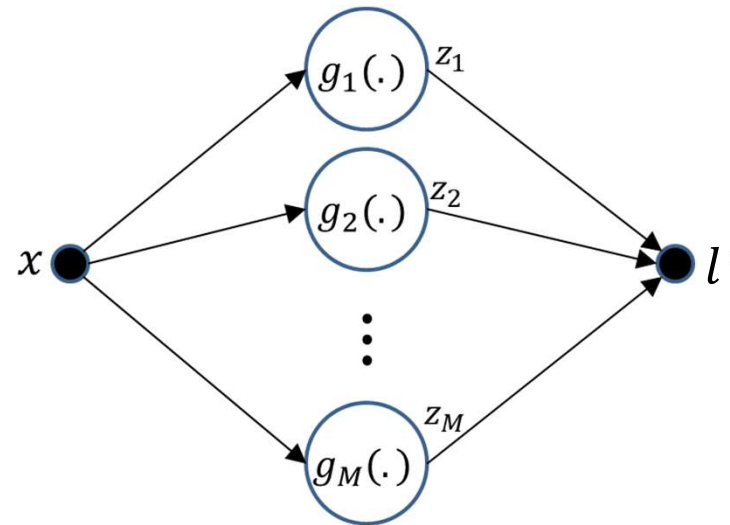

$$\frac{dl}{dx} = \frac{\partial l}{\partial z_1} \frac{dz_1}{dx} + \frac{\partial l}{\partial z_2} \frac{dz_2}{dx} + \dots + \frac{\partial l}{\partial z_M} \frac{dz_M}{dx}$$

Our problem for today

- How to compute $\frac{dDiv(\mathbf{Y}, d)}{dw_{i,j}^{(k)}}$ for a single data instance

Poll 1 (@387, @388)

1. The chain rule of derivatives can be derived from the basic definition of derivatives, $dy = \text{derivative} * dx$, true or false
 - True
 - False

2. Which of the following is true of the “influence diagram”
 - It graphically shows all paths (and variables) through which one variable influences the other
 - The derivative of the influenced (outcome) variable with respect to the influencer (input) variable must be summed over all outgoing paths from the influencer variable

Poll 1

1. The chain rule of derivatives can be derived from the basic definition of derivatives, $dy = \text{derivative} * dx$, true or false
 - True **(correct)**
 - False

2. Which of the following is true of the “influence diagram”
 - It graphically shows all paths (and variables) through which one variable influences the other **(true)**
 - The derivative of the influenced (outcome) variable with respect to the influencer (input) variable must be summed over all outgoing paths from the influencer variable **(true)**

A first closer look at the network

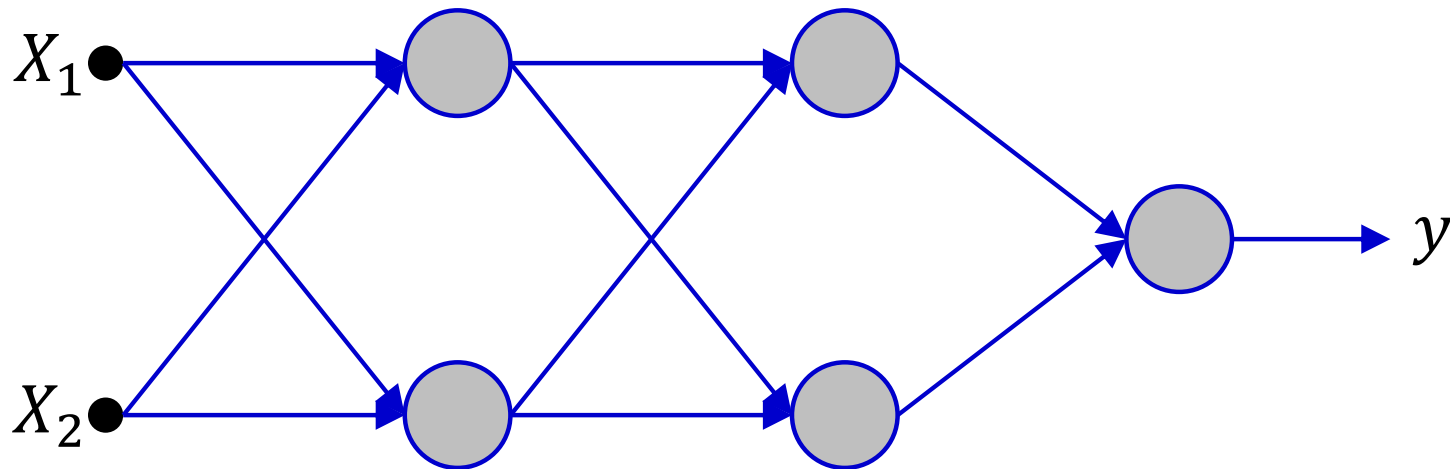

- Showing a tiny 2-input network for illustration
 - Actual network would have many more neurons and inputs

A first closer look at the network

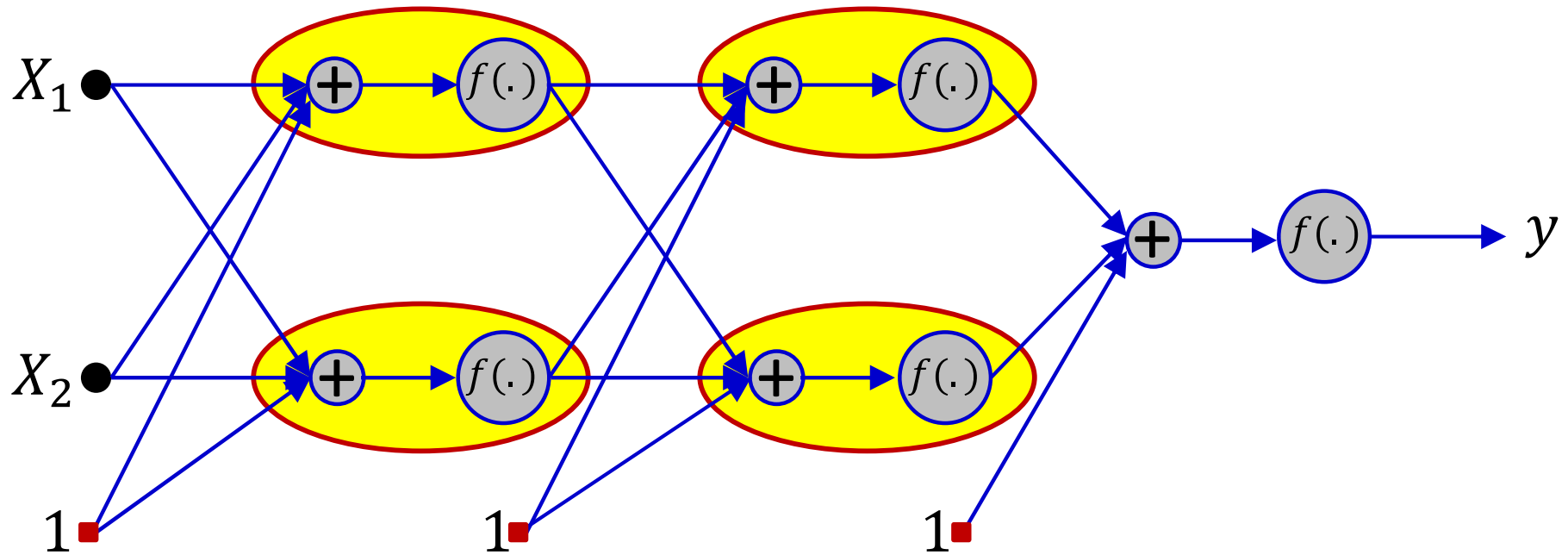

- Showing a tiny 2-input network for illustration
 - Actual network would have many more neurons and inputs
- Explicitly separating the affine function of inputs from the activation

A first closer look at the network

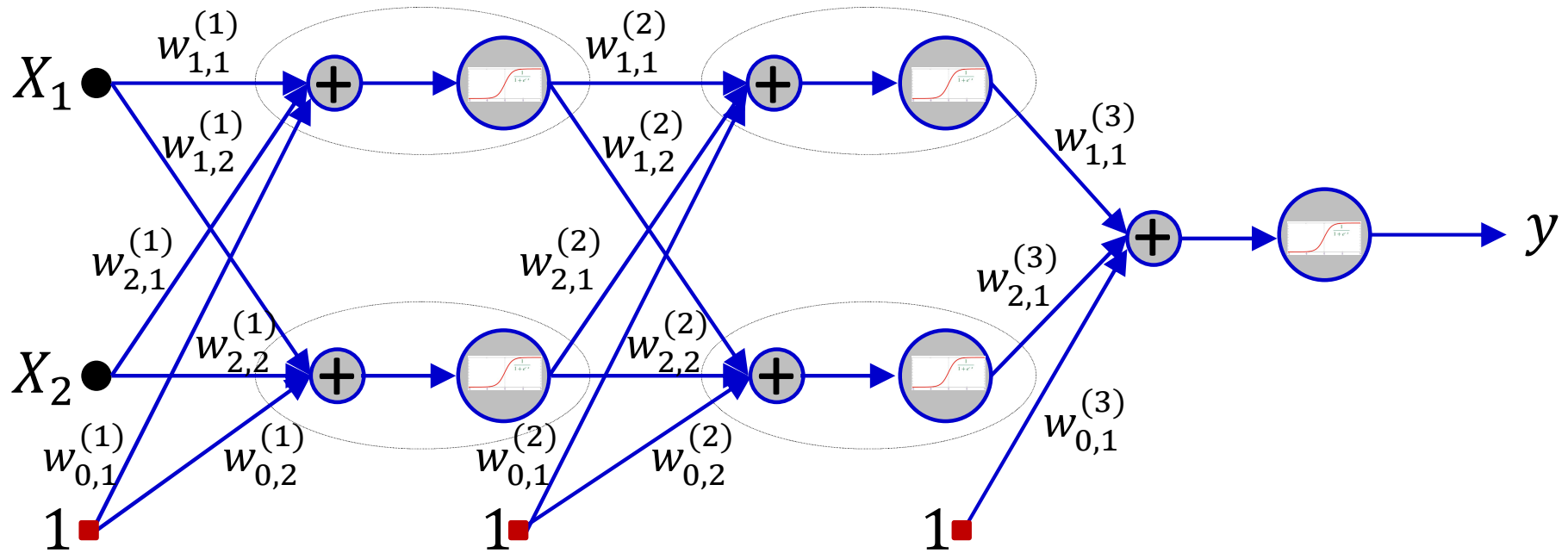

- Showing a tiny 2-input network for illustration
 - Actual network would have many more neurons and inputs
- Expanded **with all weights shown**
- Let's label the other variables too...

Computing the derivative for a *single* input

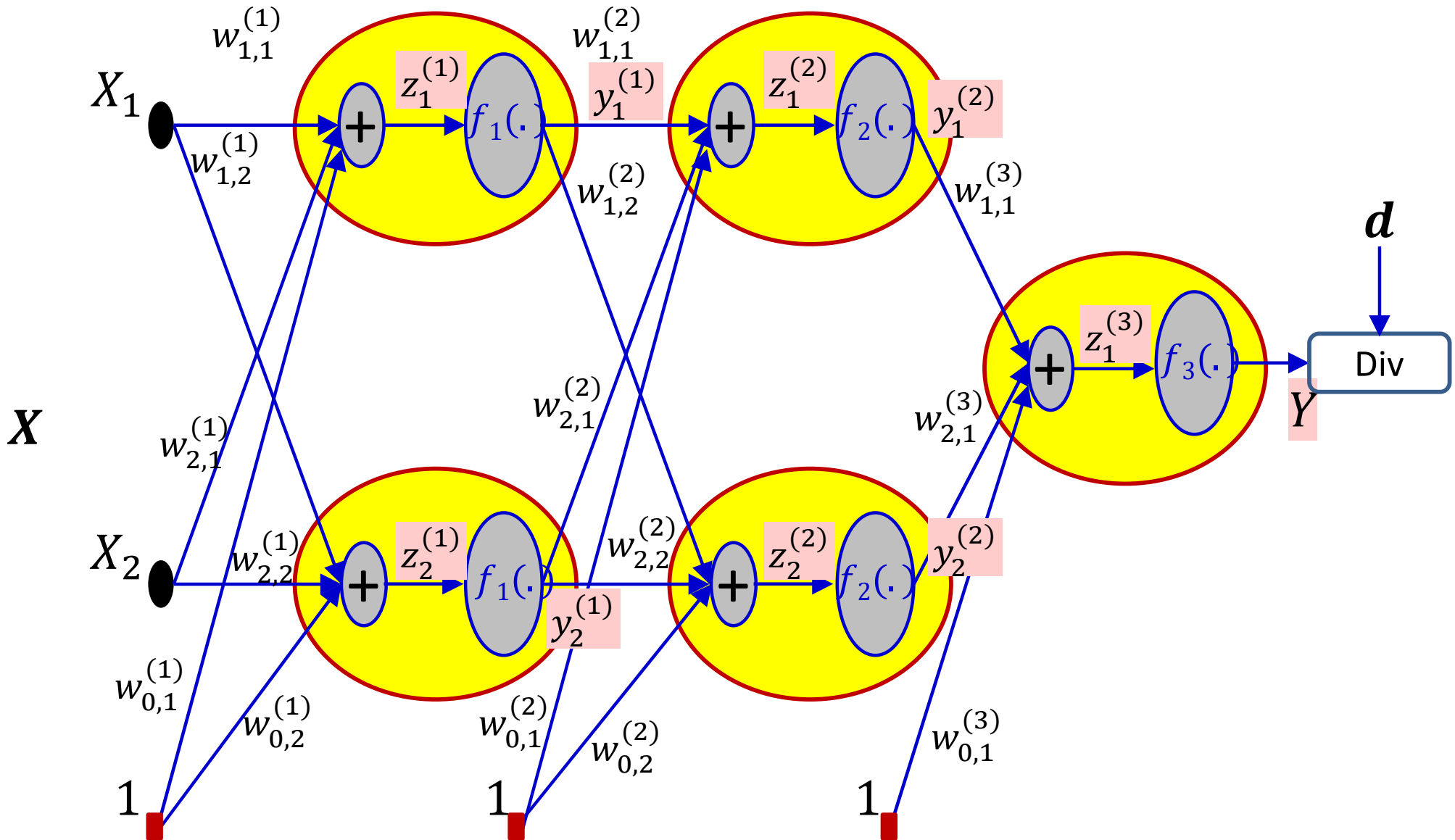

Computing the derivative for a *single* input

What is: $\frac{dDiv(Y,d)}{dw_{i,j}^{(k)}}$

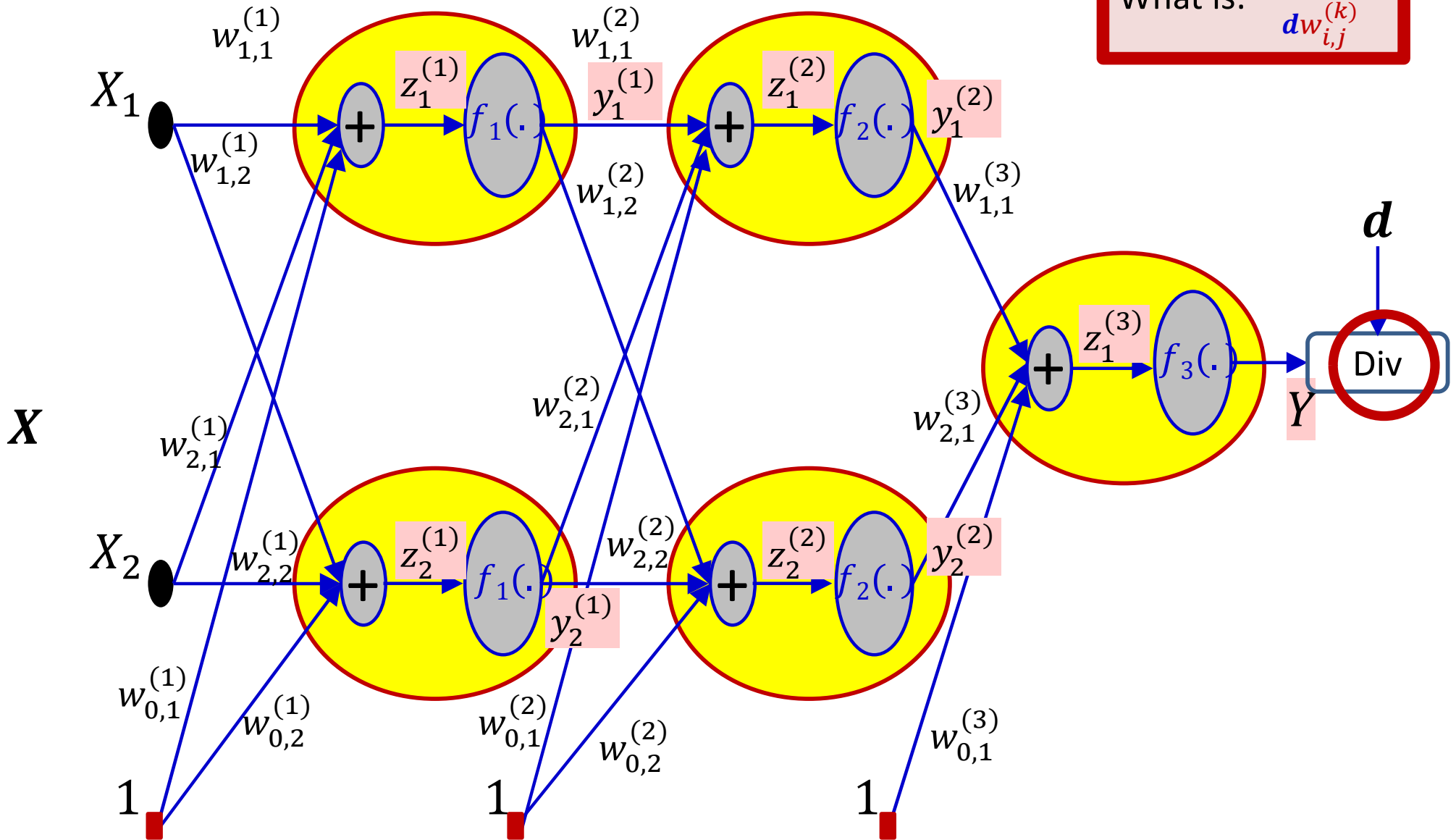

Computing the gradient

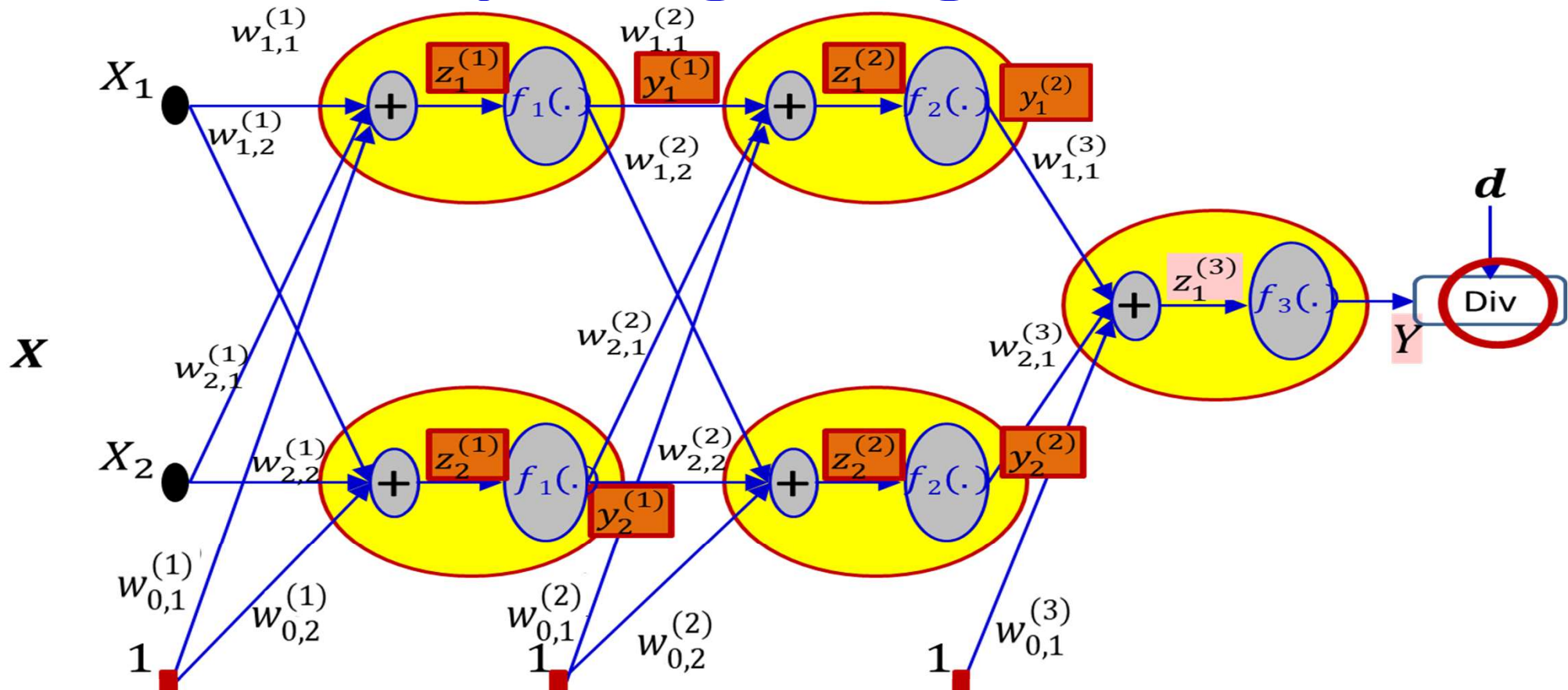

- Note: computation of the derivative $\frac{dDiv(Y,d)}{dw_{i,j}^{(k)}}$ requires intermediate and final output values of the network in response to the input

The “forward pass”

$$y^{(0)} = x$$

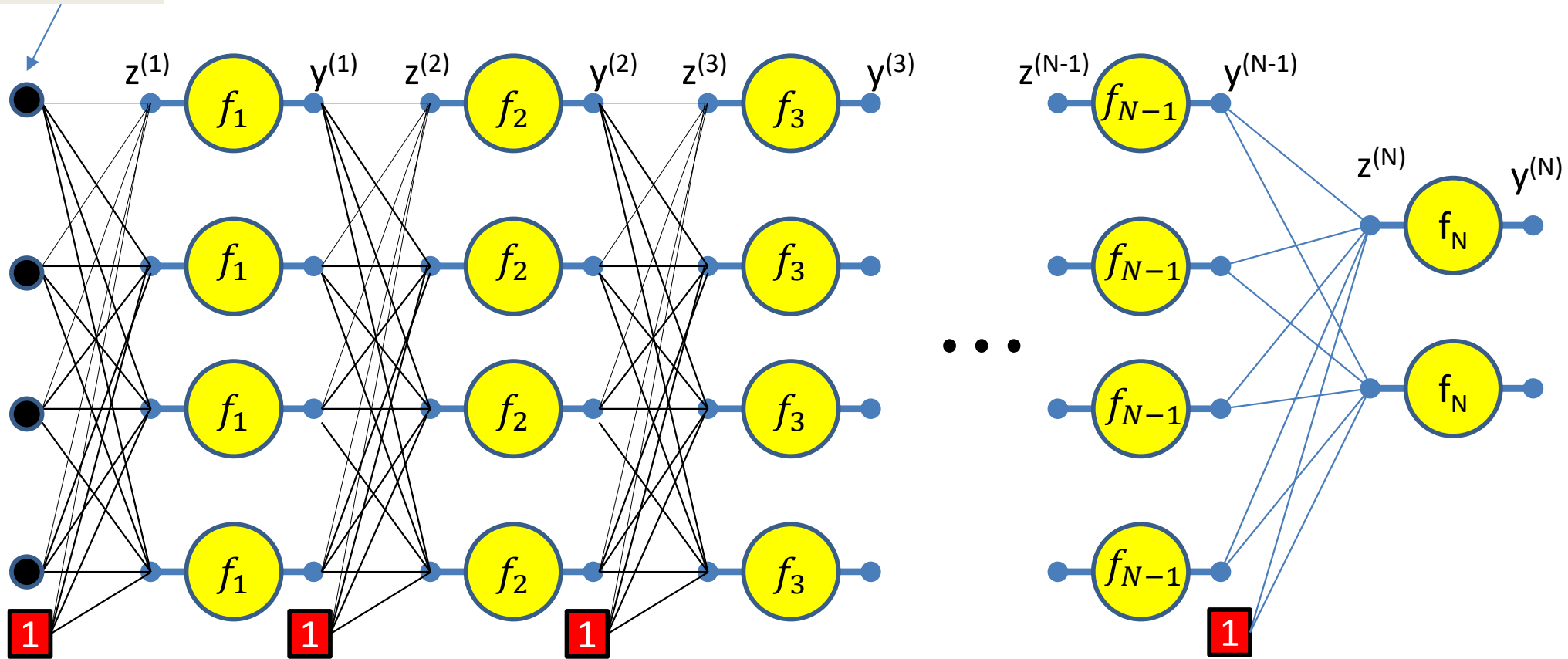

Setting $y_i^{(0)} = x_i$ for notational convenience

Assuming $w_{0j}^{(k)} = b_j^{(k)}$ and $y_0^{(k)} = 1$ -- assuming the bias is a weight and extending the output of every layer by a constant 1, to account for the biases

The "forward pass"

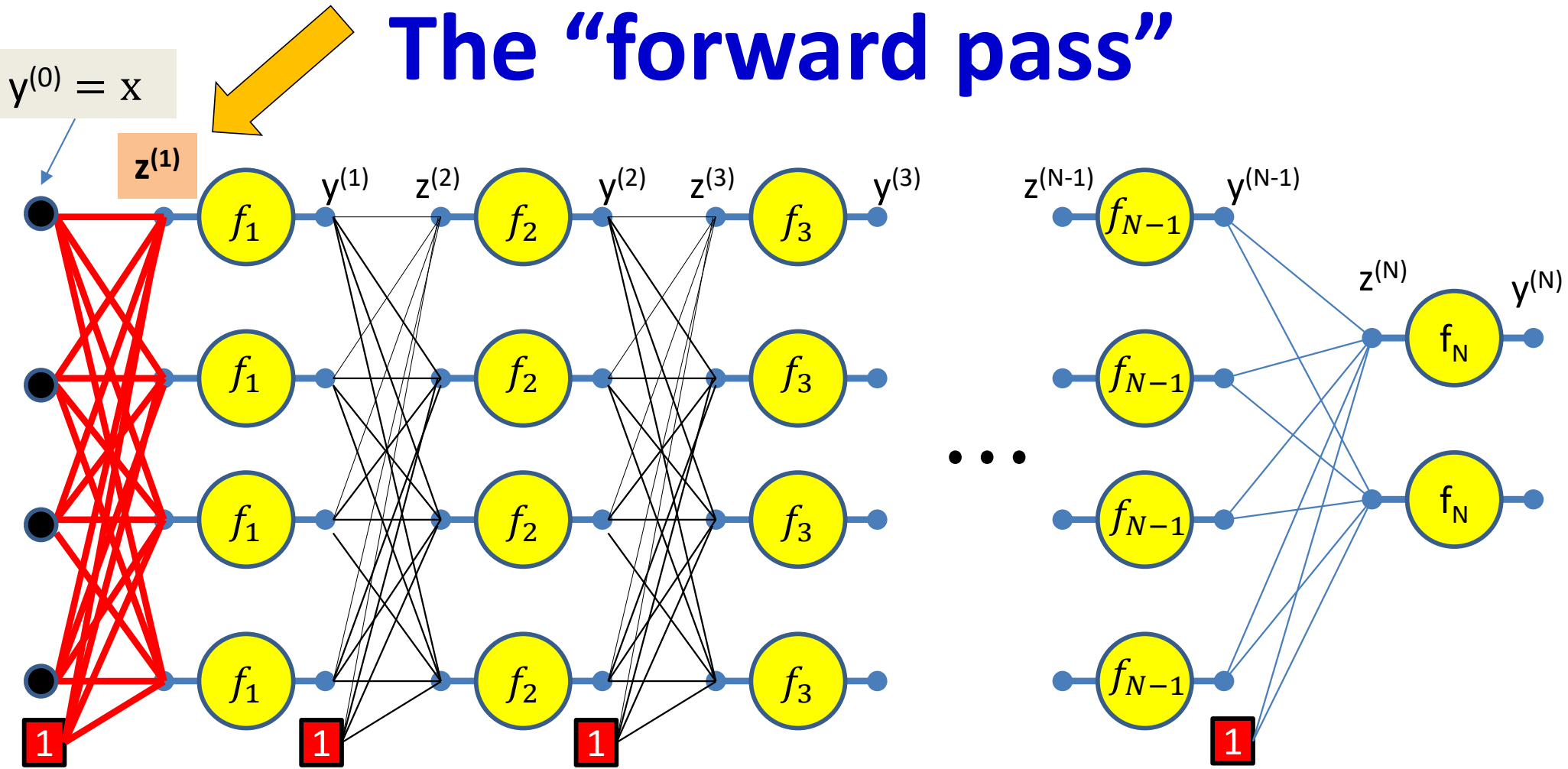

$$z_j^{(1)} = \sum_i w_{ij}^{(1)} y_i^{(0)}$$

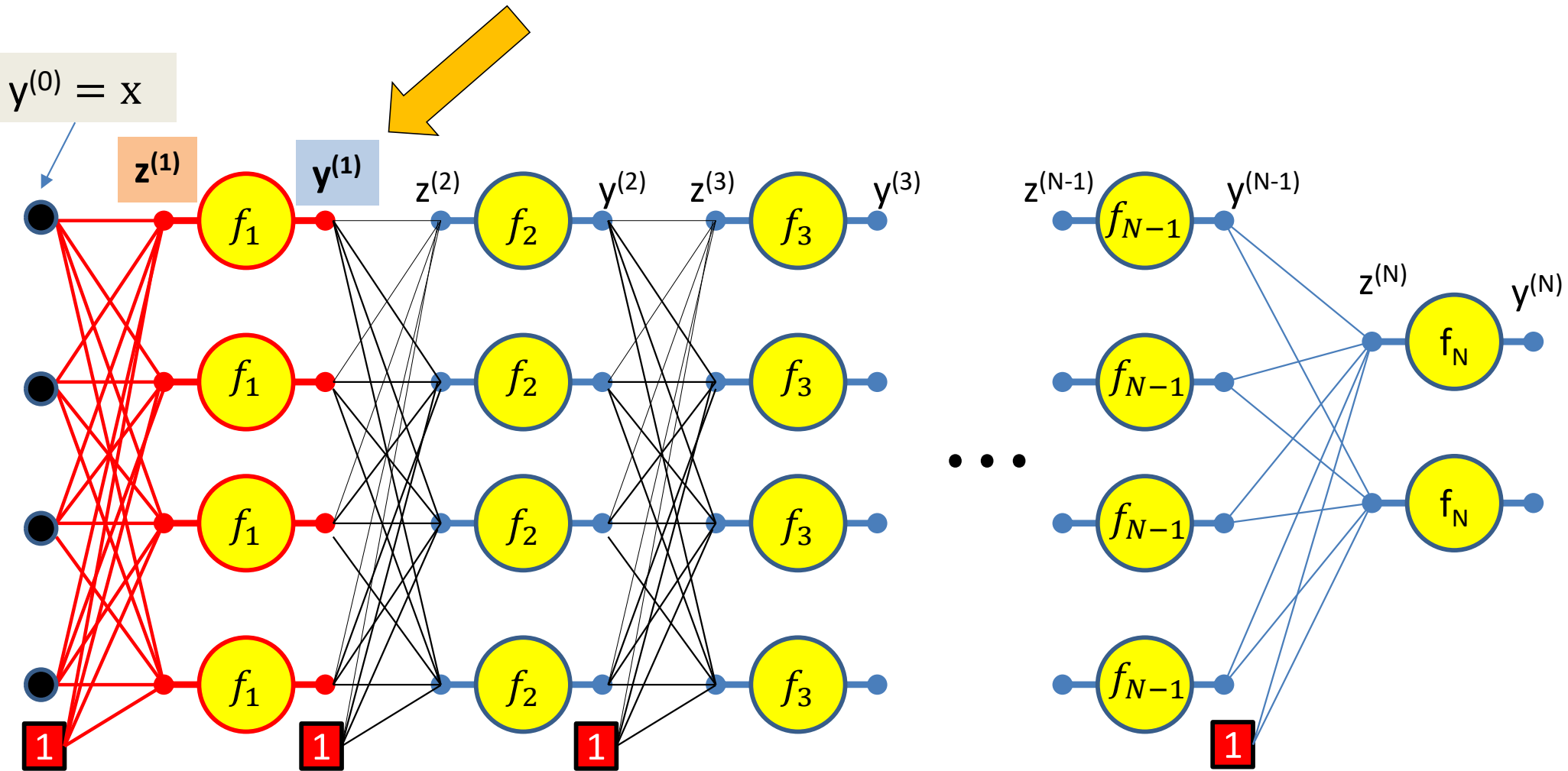

$$z_j^{(1)} = \sum_i w_{ij}^{(1)} y_i^{(0)}$$

$$y_j^{(1)} = f_1(z_j^{(1)})$$

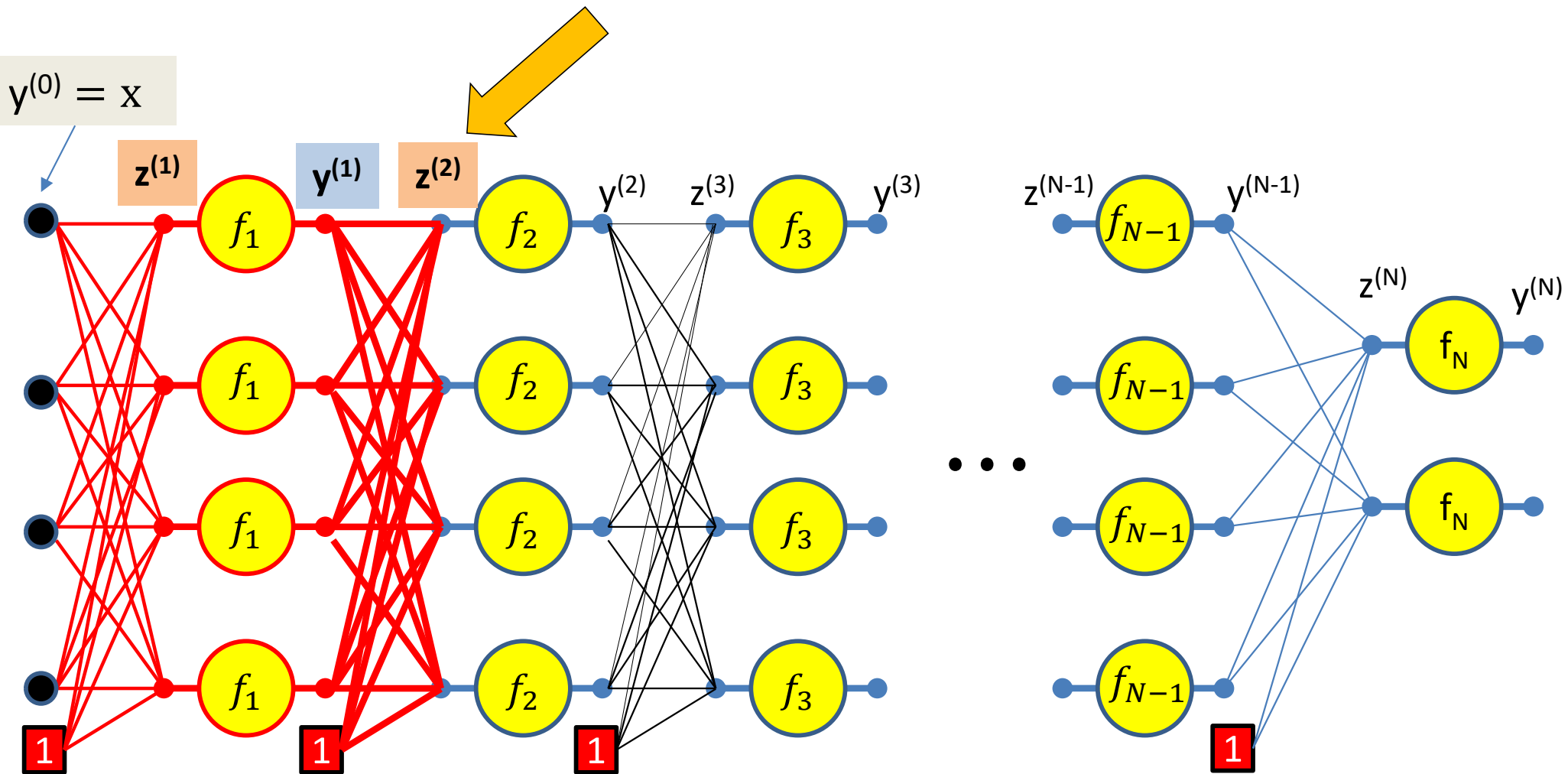

$$z_j^{(1)} = \sum_i w_{ij}^{(1)} y_i^{(0)}$$

$$y_j^{(1)} = f_1(z_j^{(1)})$$

$$z_j^{(2)} = \sum_i w_{ij}^{(2)} y_i^{(1)}$$

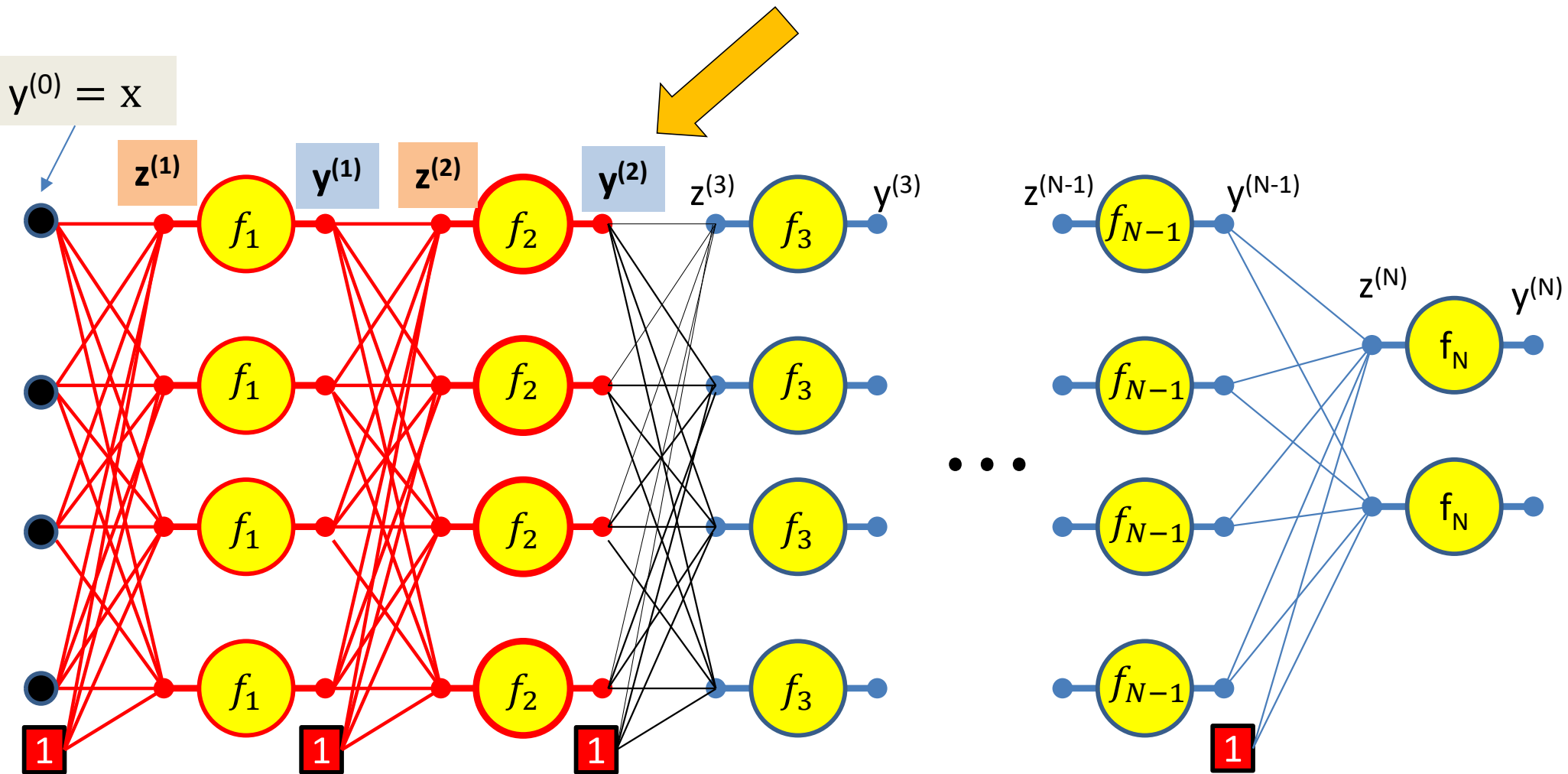

$$z_j^{(1)} = \sum_i w_{ij}^{(1)} y_i^{(0)}$$

$$y_j^{(1)} = f_1(z_j^{(1)})$$

$$z_j^{(2)} = \sum_i w_{ij}^{(2)} y_i^{(1)}$$

$$y_j^{(2)} = f_2(z_j^{(2)})$$

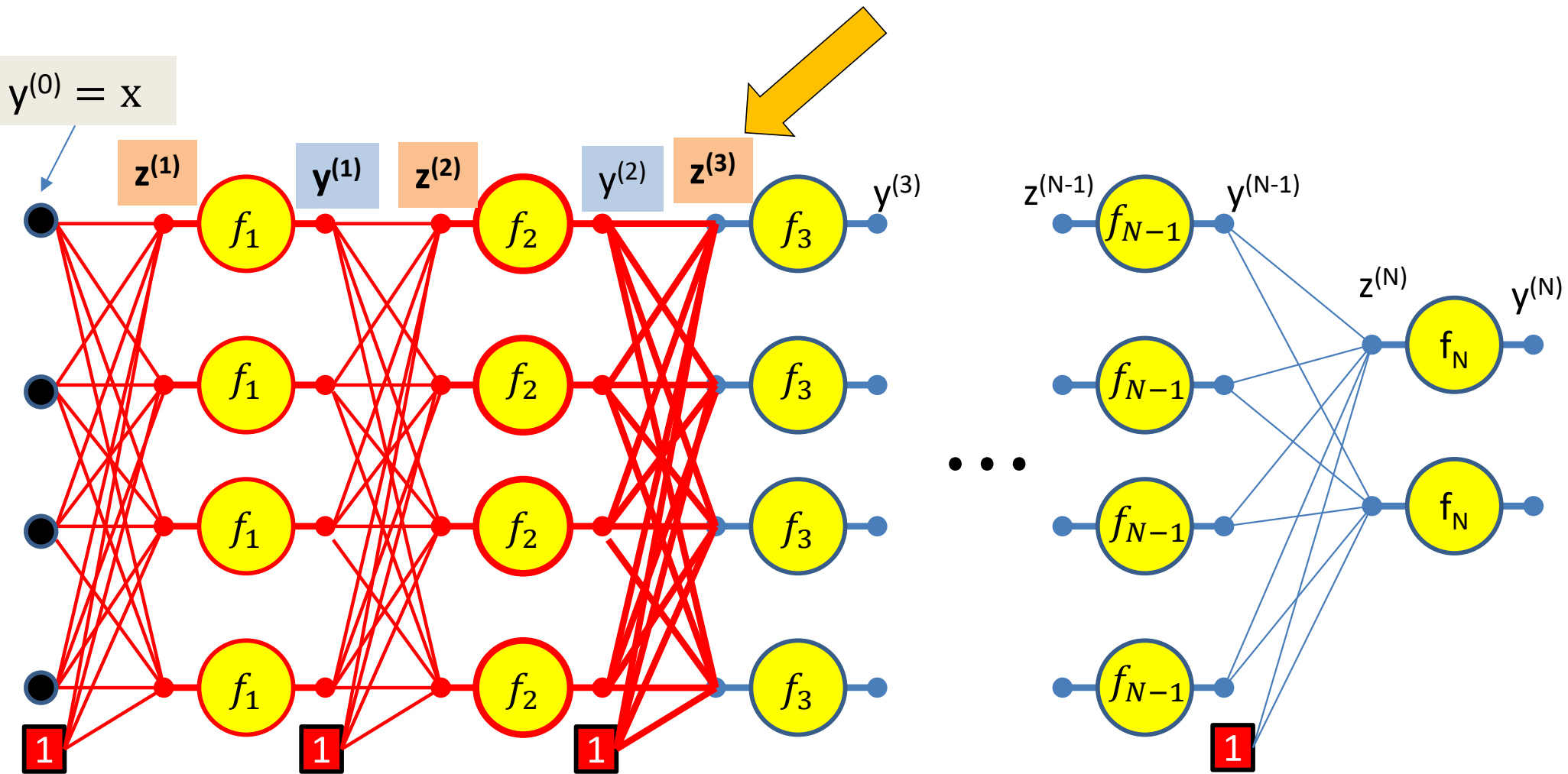

$$z_j^{(1)} = \sum_i w_{ij}^{(1)} y_i^{(0)}$$

$$y_j^{(1)} = f_1(z_j^{(1)})$$

$$z_j^{(2)} = \sum_i w_{ij}^{(2)} y_i^{(1)}$$

$$y_j^{(2)} = f_2(z_j^{(2)})$$

$$z_j^{(3)} = \sum_i w_{ij}^{(3)} y_i^{(2)}$$

$$y^{(0)} = x$$

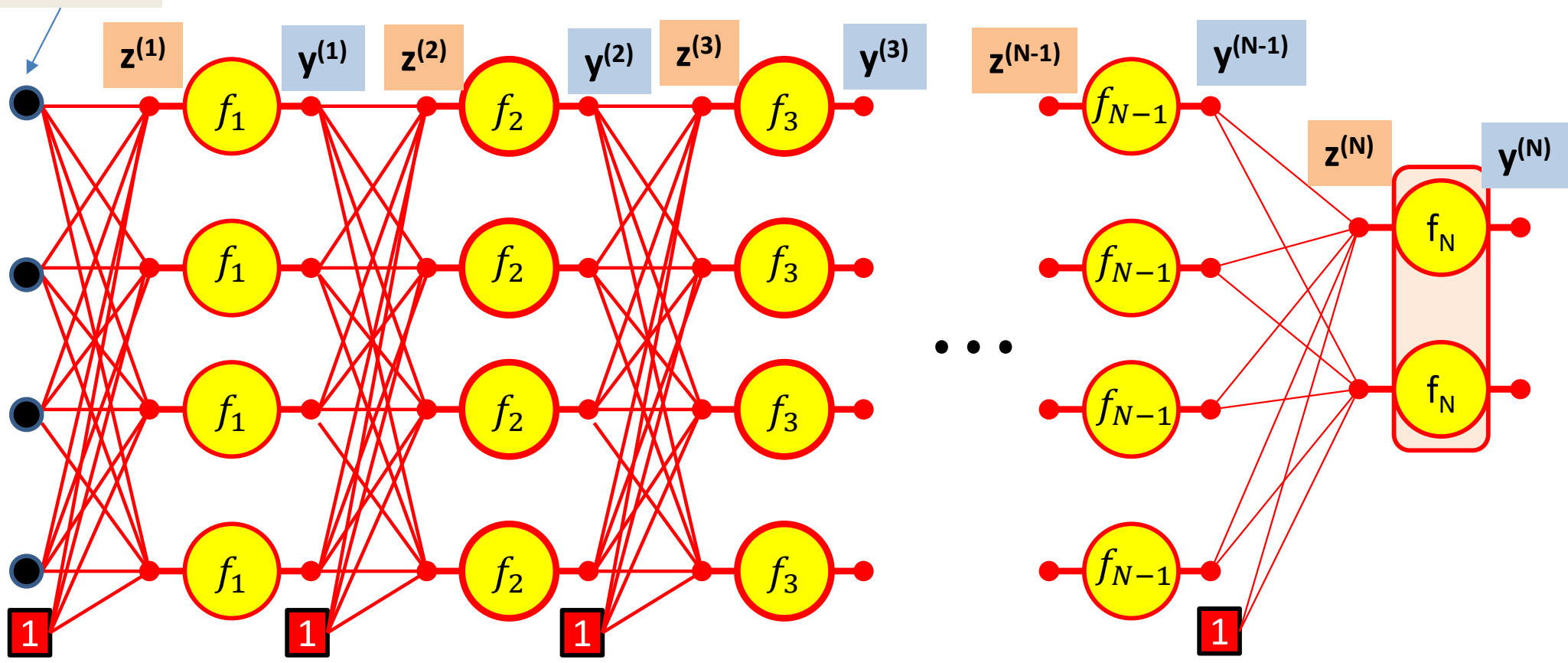

$$y_j^{(N-1)} = f_{N-1}(z_j^{(N-1)})$$

$$z_j^{(N)} = \sum_i w_{ij}^{(N)} y_i^{(N-1)}$$

$$y^{(N)} = f_N(z^{(N)})$$

Forward Computation

$$y^{(0)} = x$$

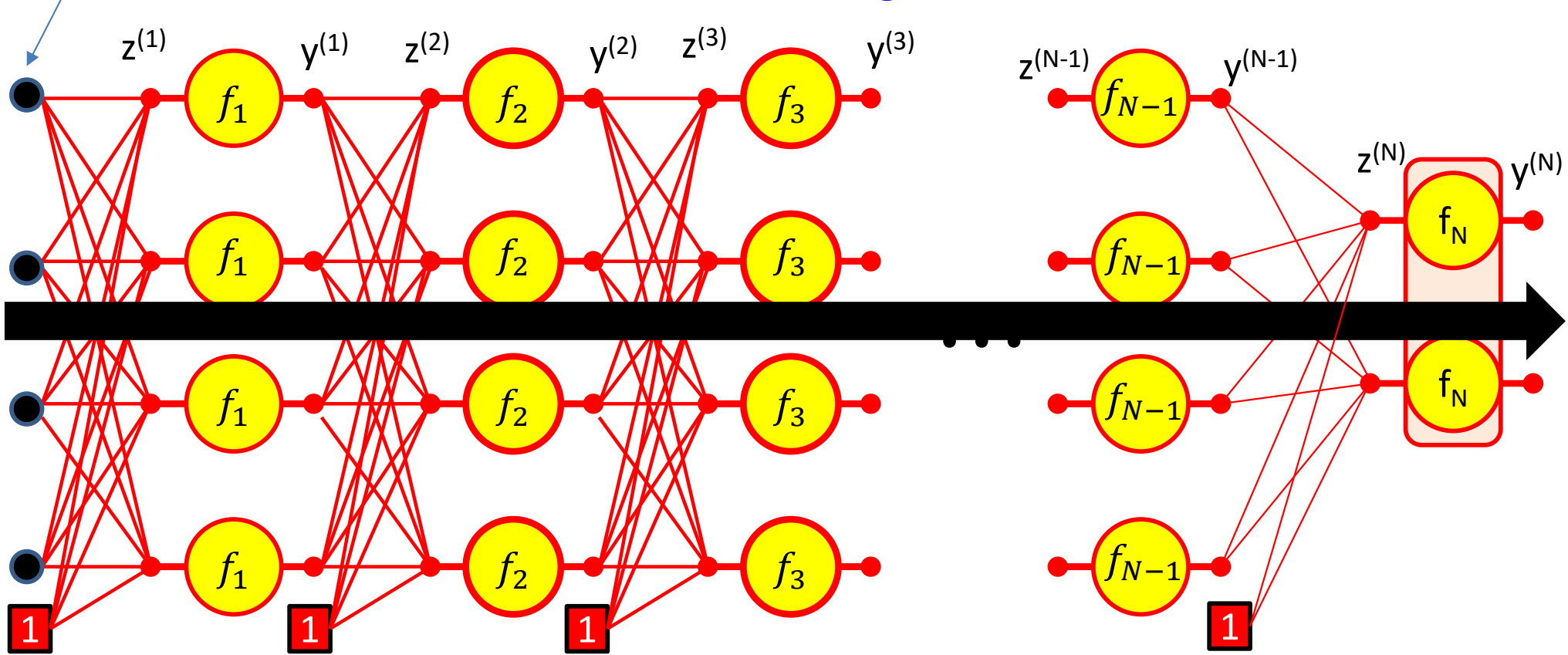

ITERATE FOR $k = 1:N$

for $j = 1:\text{layer-width}$

$$y_i^{(0)} = x_i$$

$$z_j^{(k)} = \sum_i w_{ij}^{(k)} y_i^{(k-1)}$$

$$y_j^{(k)} = f_k(z_j^{(k)})$$

Forward “Pass”

- Input: D dimensional vector $\mathbf{x} = [x_j, j = 1 \dots D]$
- Set:
 - $D_0 = D$, is the width of the 0th (input) layer
 - $y_j^{(0)} = x_j, j = 1 \dots D; \quad y_0^{(k=1 \dots N)} = x_0 = 1$
- For layer $k = 1 \dots N$
 - For $j = 1 \dots D_k$ D_k is the size of the k th layer
 - $z_j^{(k)} = \sum_{i=0}^{D_{k-1}} w_{i,j}^{(k)} y_i^{(k-1)}$
 - $y_j^{(k)} = f_k(z_j^{(k)})$
- Output:
 - $Y = y_j^{(N)}, j = 1 \dots D_N$

Computing derivatives

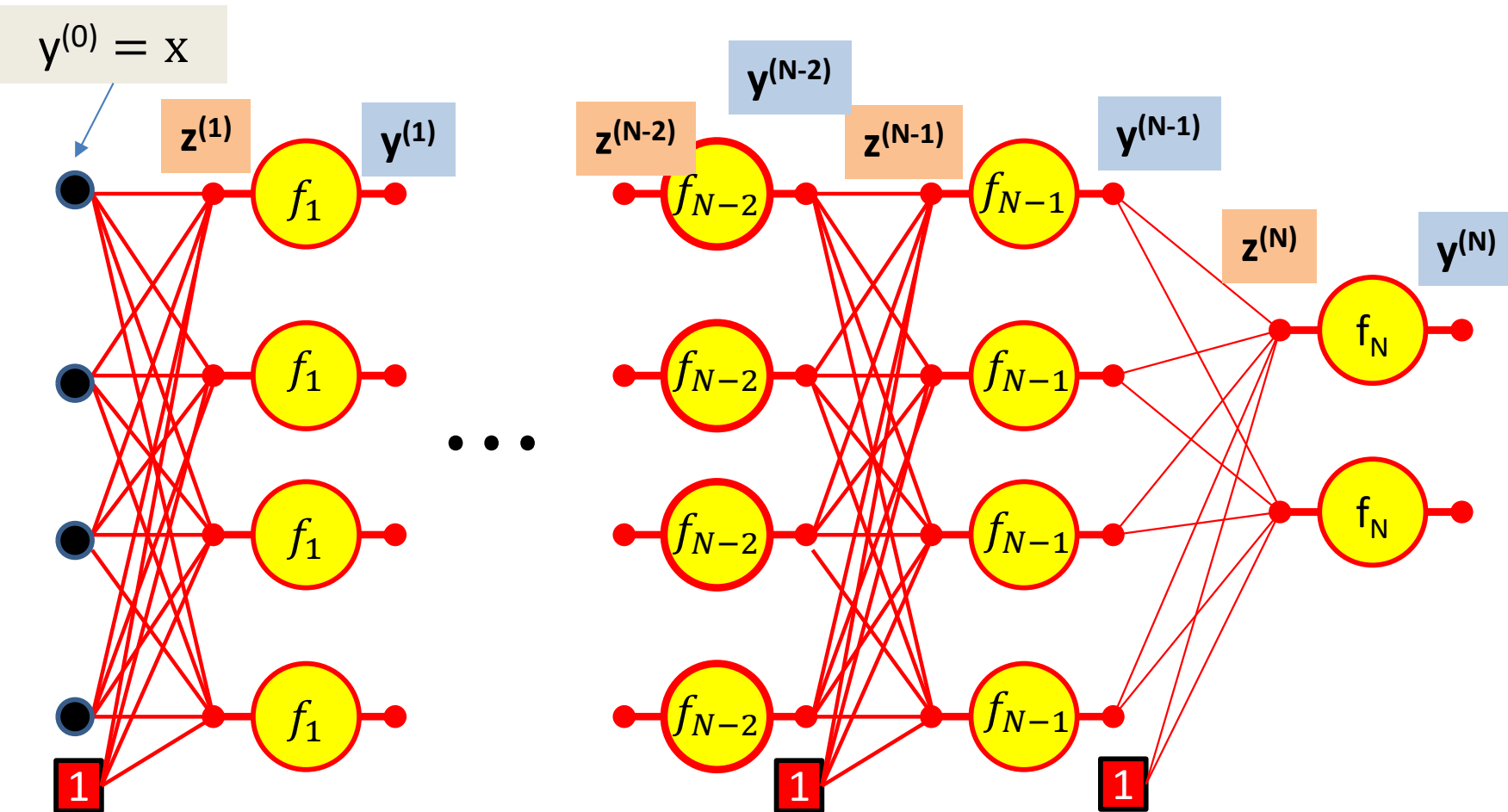

We have computed all these intermediate values in the forward computation

We must remember them - we will need them to compute the derivatives

Computing derivatives

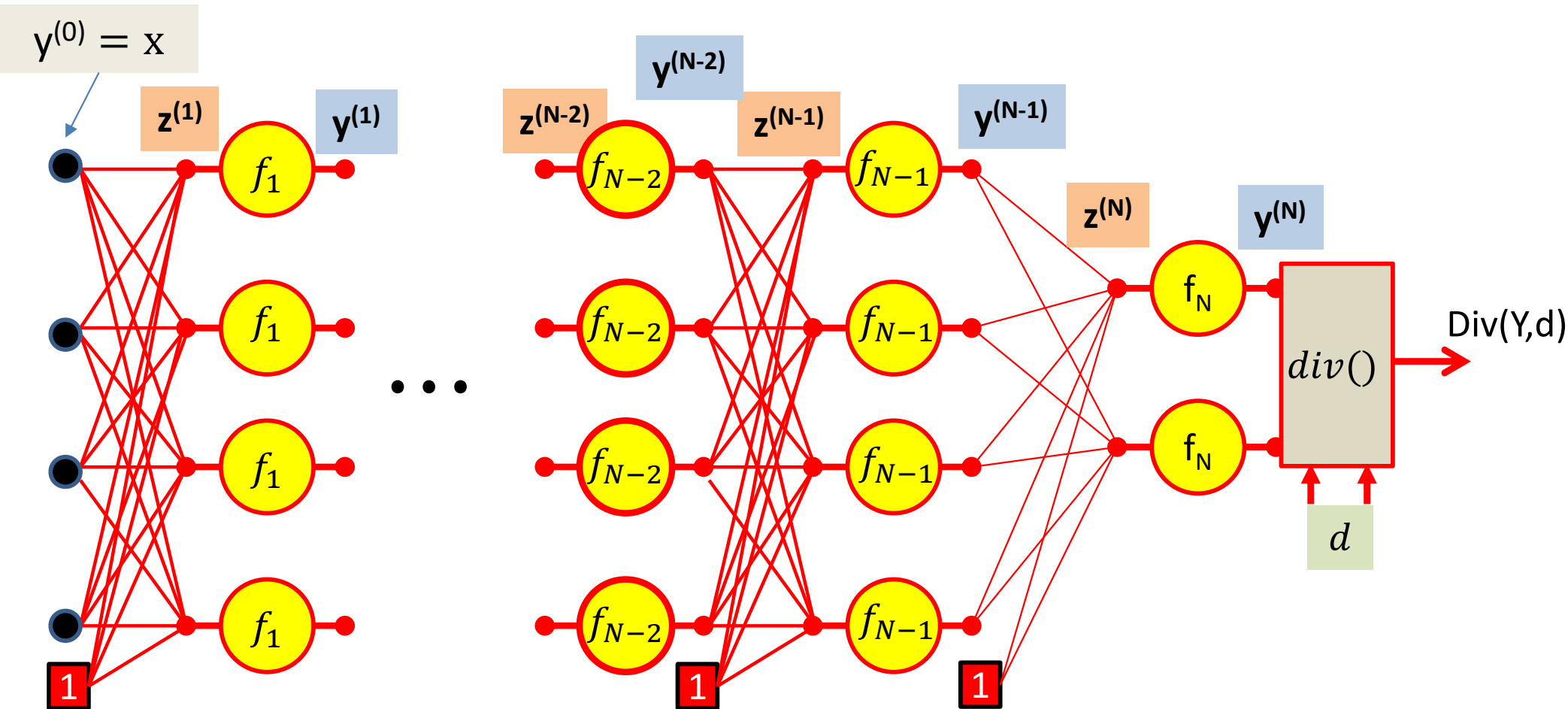

First, we compute the divergence between the output of the net $y = y^{(N)}$ and the desired output d

Computing derivatives

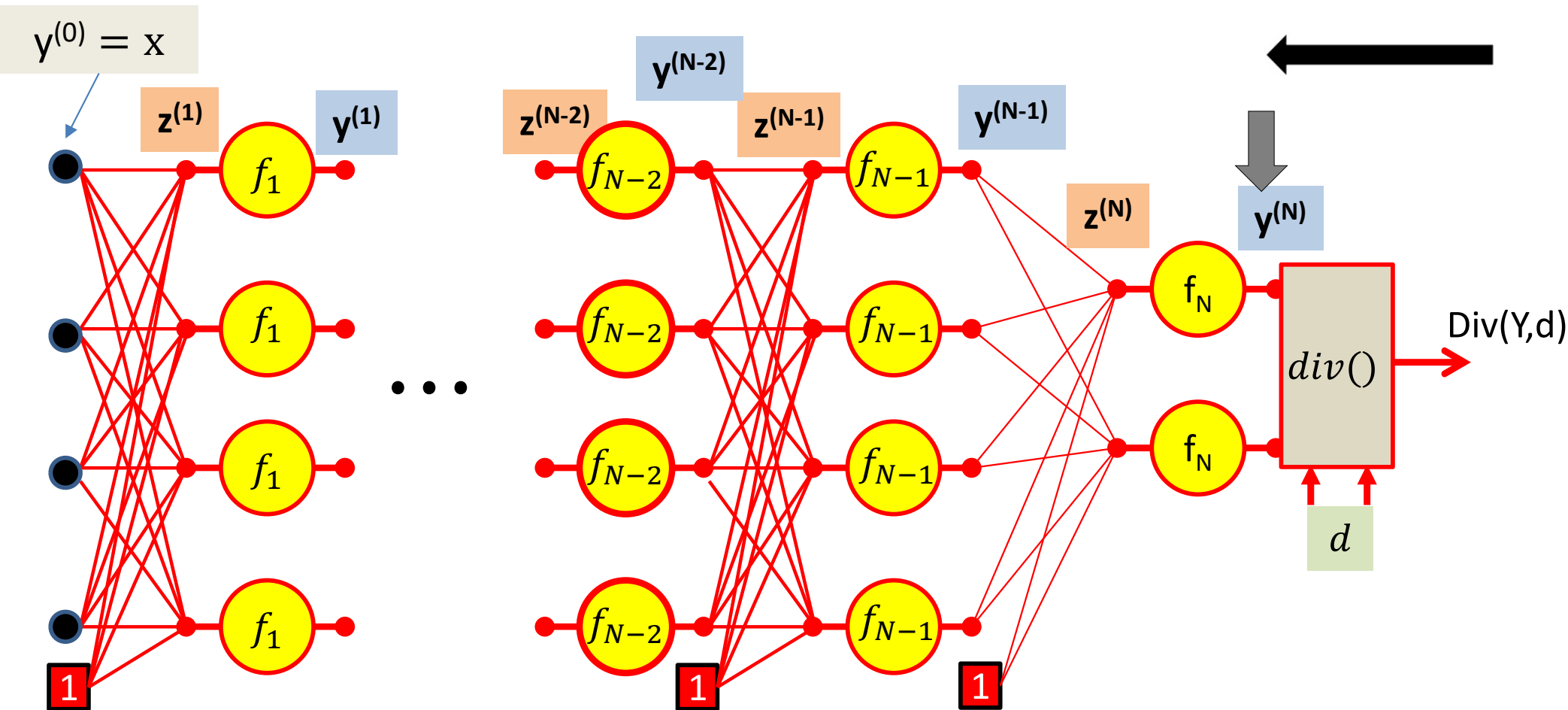

We then compute $\nabla_{y^{(N)}} div(\cdot)$ the derivative of the divergence w.r.t. the final output of the network $y^{(N)}$

Computing derivatives

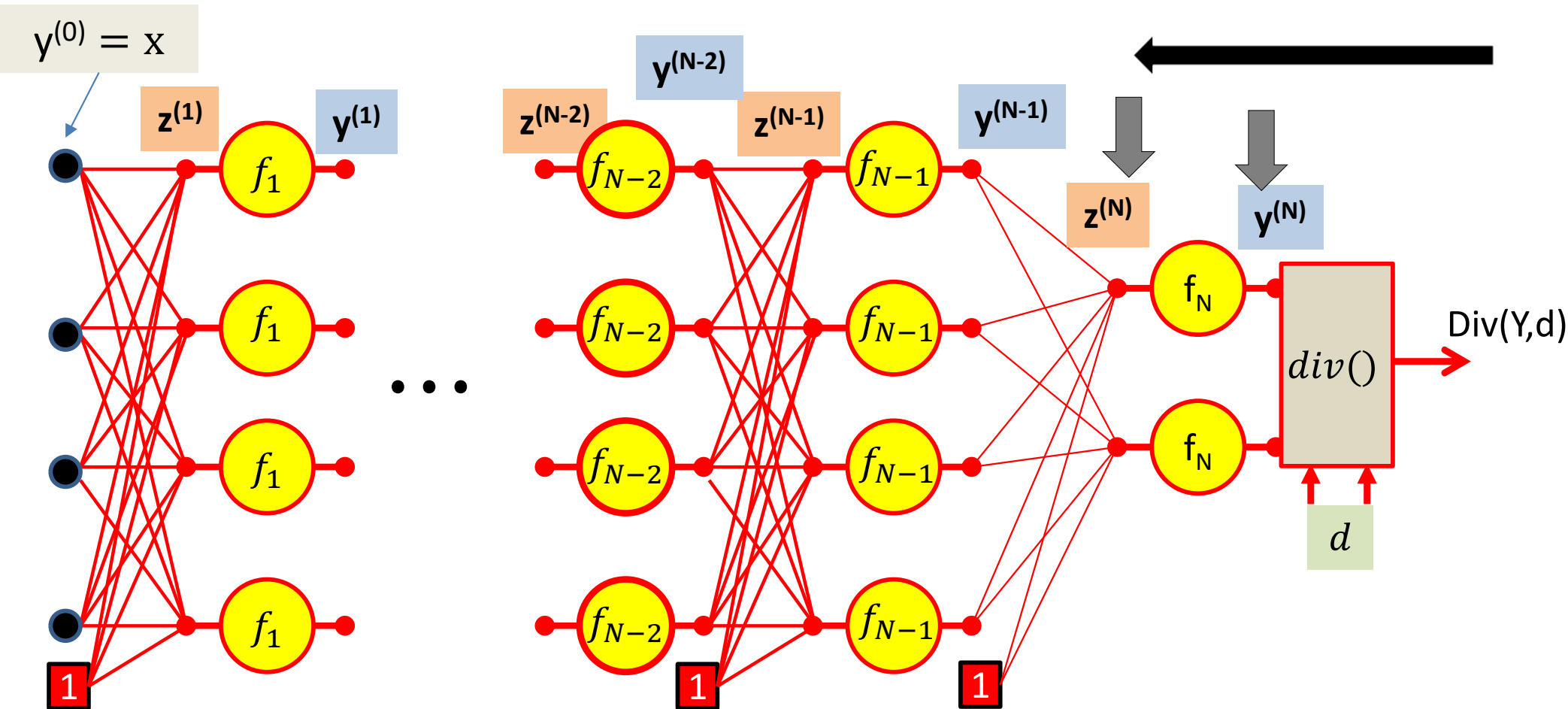

We then compute $\nabla_{y^{(N)}} div(.)$ the derivative of the divergence w.r.t. the final output of the network $y^{(N)}$

We then compute $\nabla_{z^{(N)}} div(.)$ the derivative of the divergence w.r.t. the *pre-activation* affine combination $z^{(N)}$ using the chain rule

Computing derivatives

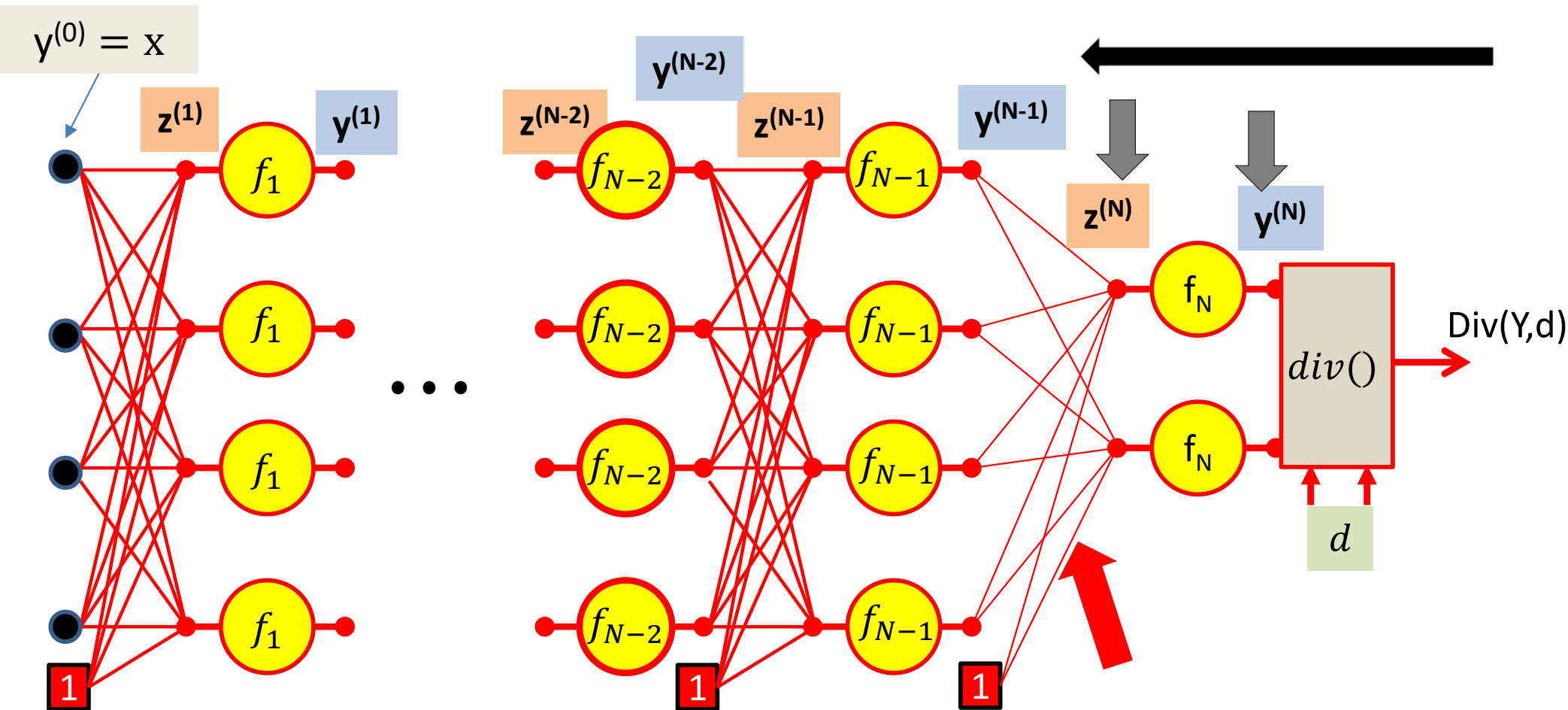

Continuing on, we will compute $\nabla_{W^{(N)}} div(.)$ the derivative of the divergence with respect to the weights of the connections to the output layer

Computing derivatives

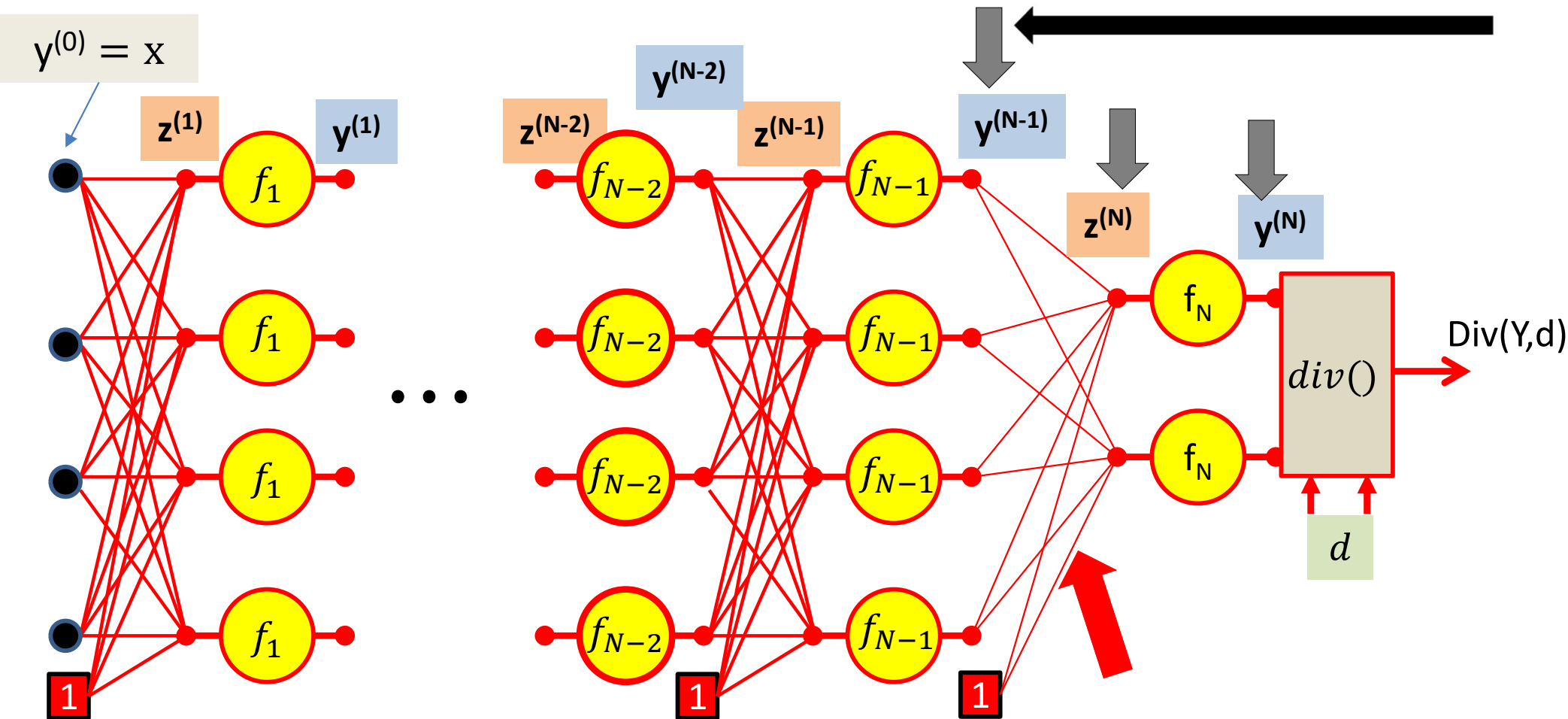

Continuing on, we will compute $\nabla_{W^{(N)}} div(.)$ the derivative of the divergence with respect to the weights of the connections to the output layer

Then continue with the chain rule to compute $\nabla_{y^{(N-1)}} div(.)$ the derivative of the divergence w.r.t. the output of the $N-1$ th layer

Computing derivatives

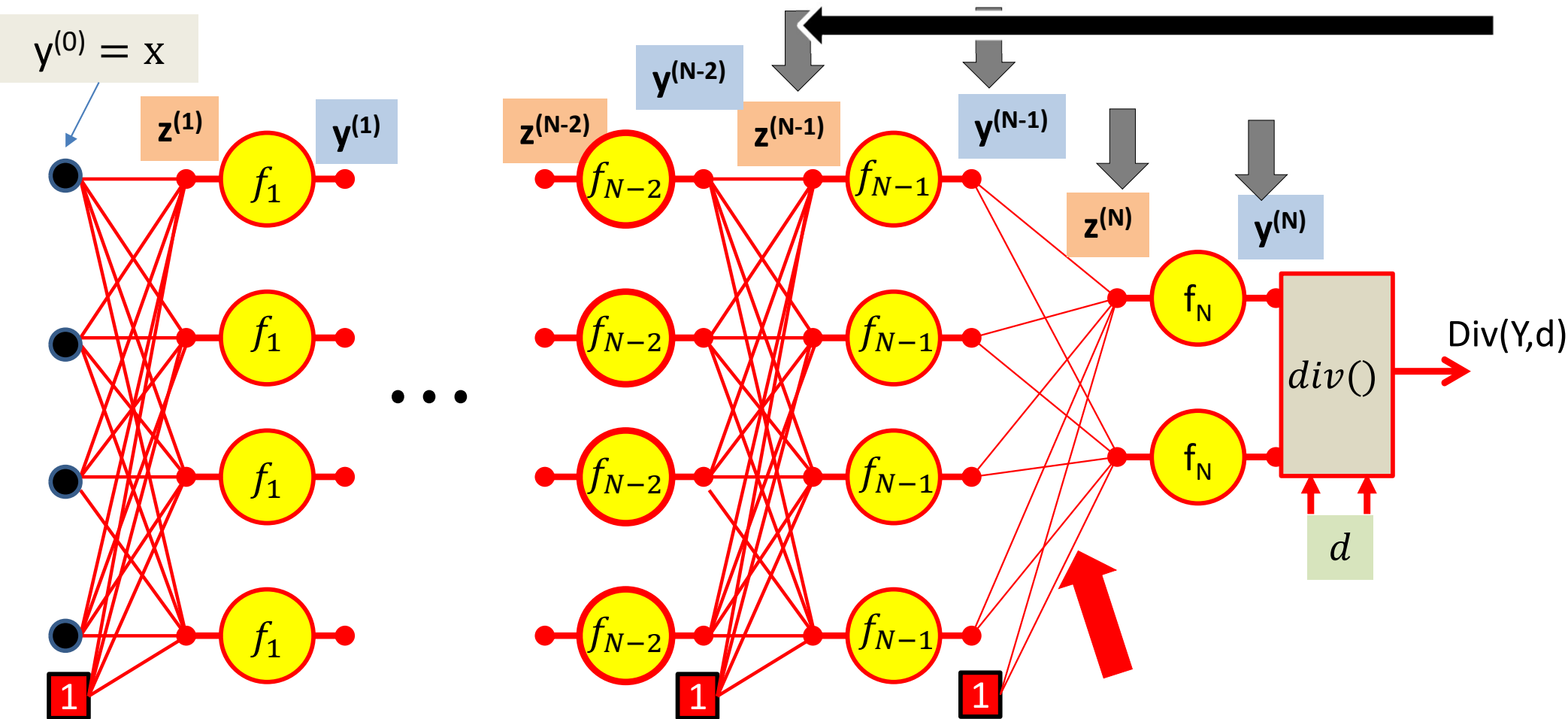

We continue our way backwards in the order shown

$$\nabla_{z^{(N-1)}} div(.)$$

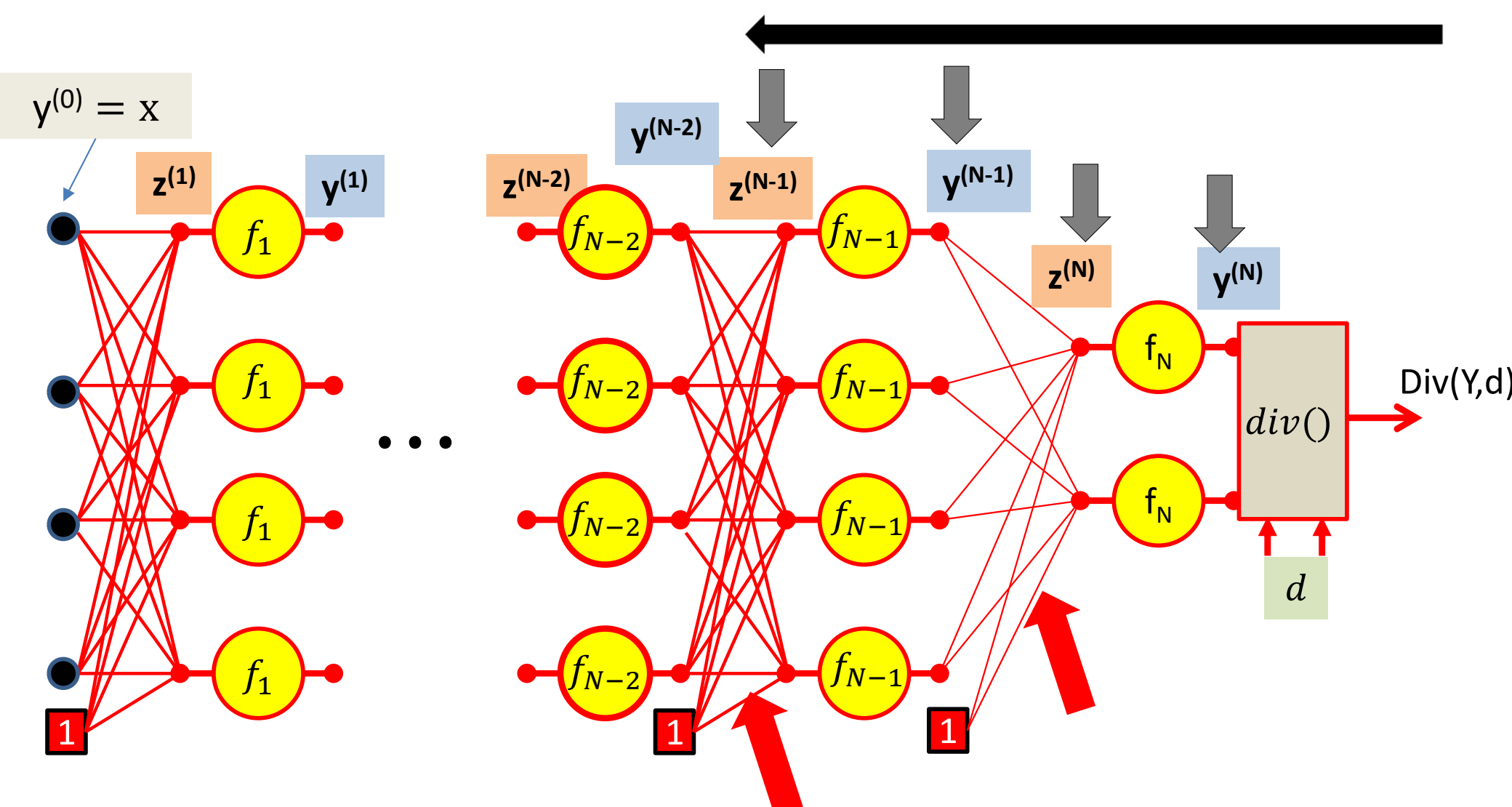

We continue our way backwards in the order shown

$$\nabla_{W^{(N-1)}} \text{div}(\cdot)$$

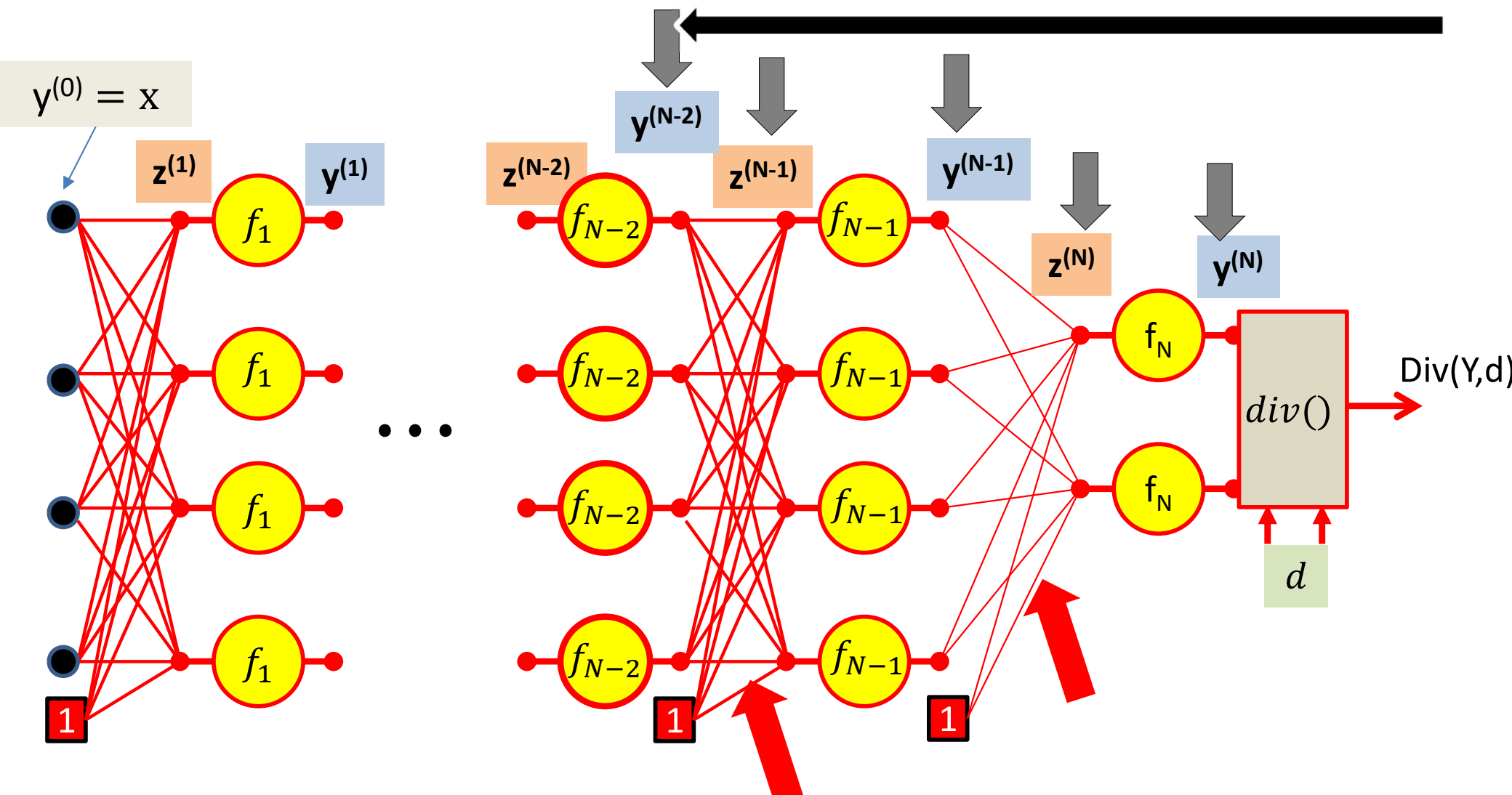

We continue our way backwards in the order shown

$$\nabla_{Y^{(N-2)}} div(.)$$

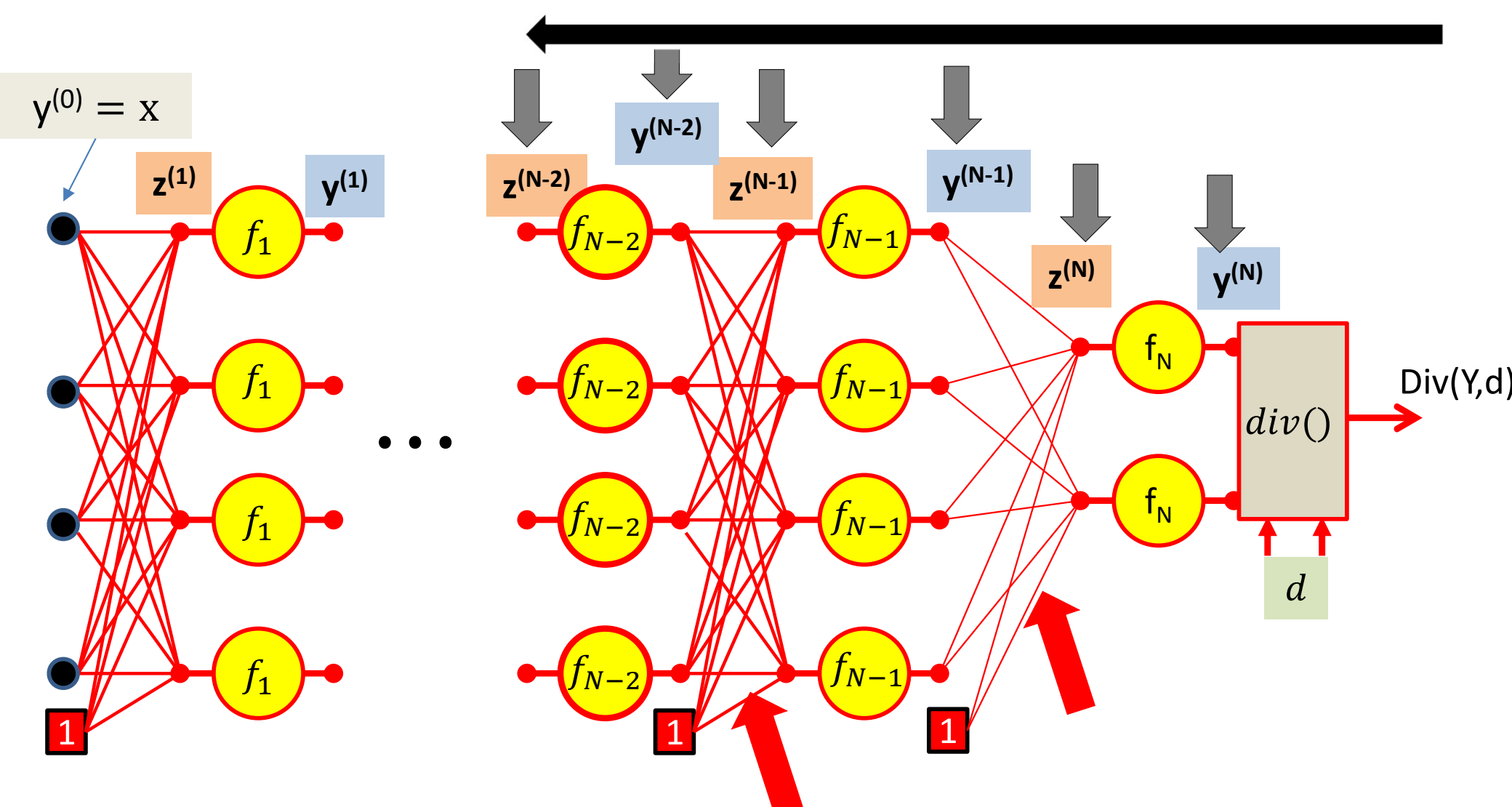

We continue our way backwards in the order shown

$$\nabla_{z^{(N-2)}} div(.)$$

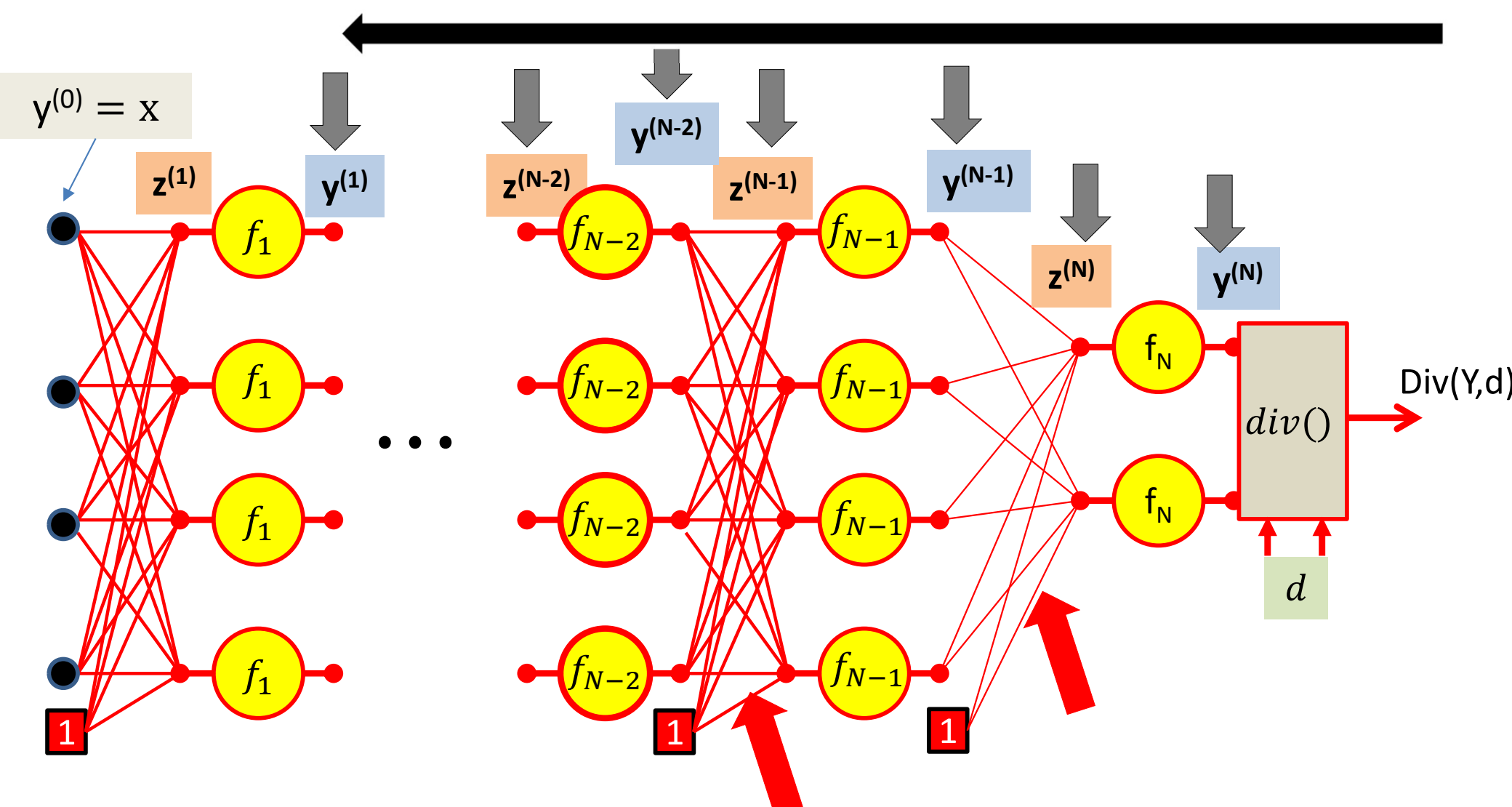

We continue our way backwards in the order shown

$$\nabla_{Y^{(1)}} div(.)$$

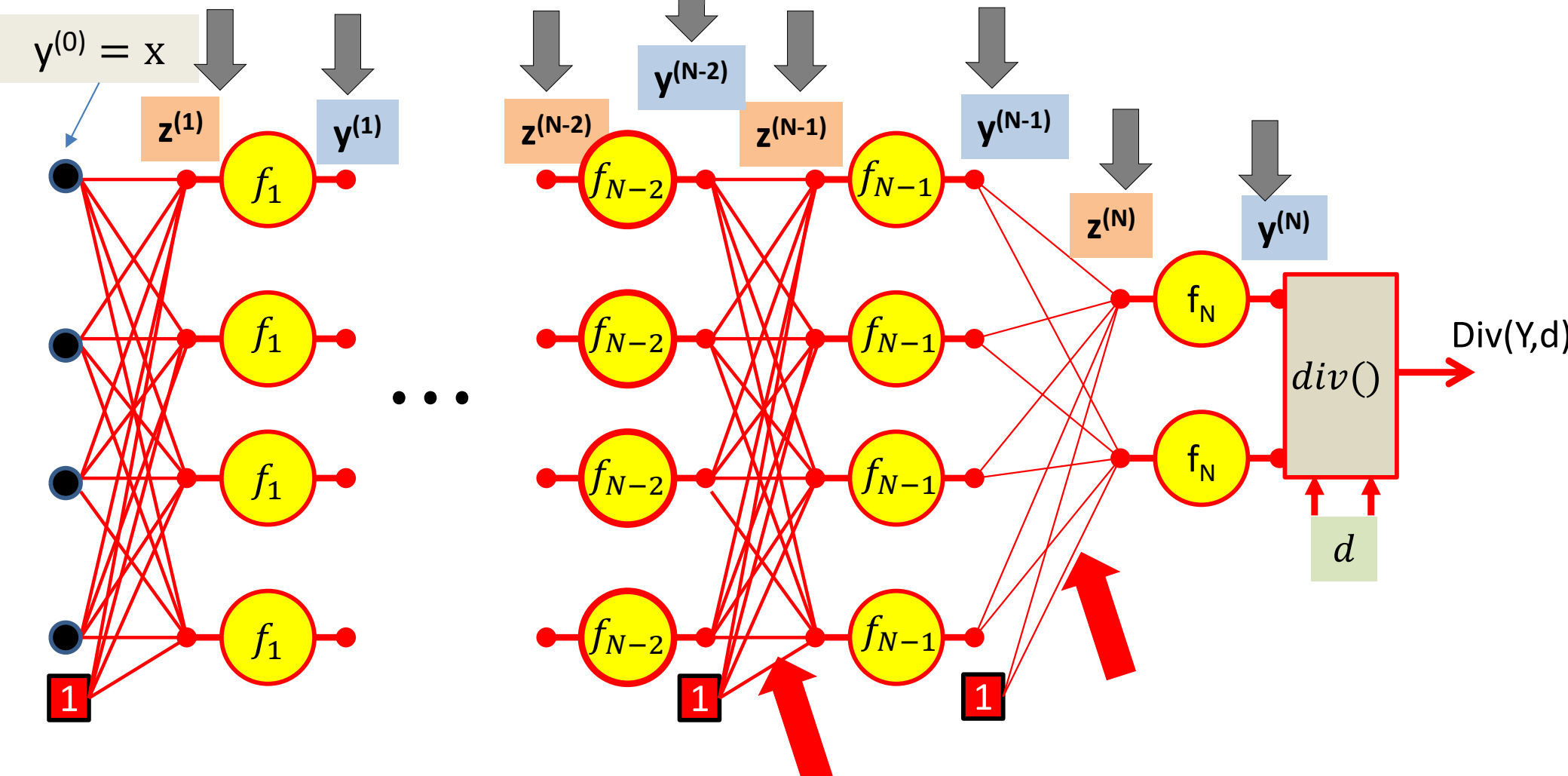

We continue our way backwards in the order shown

$$\nabla_{z^{(1)}} div(.)$$

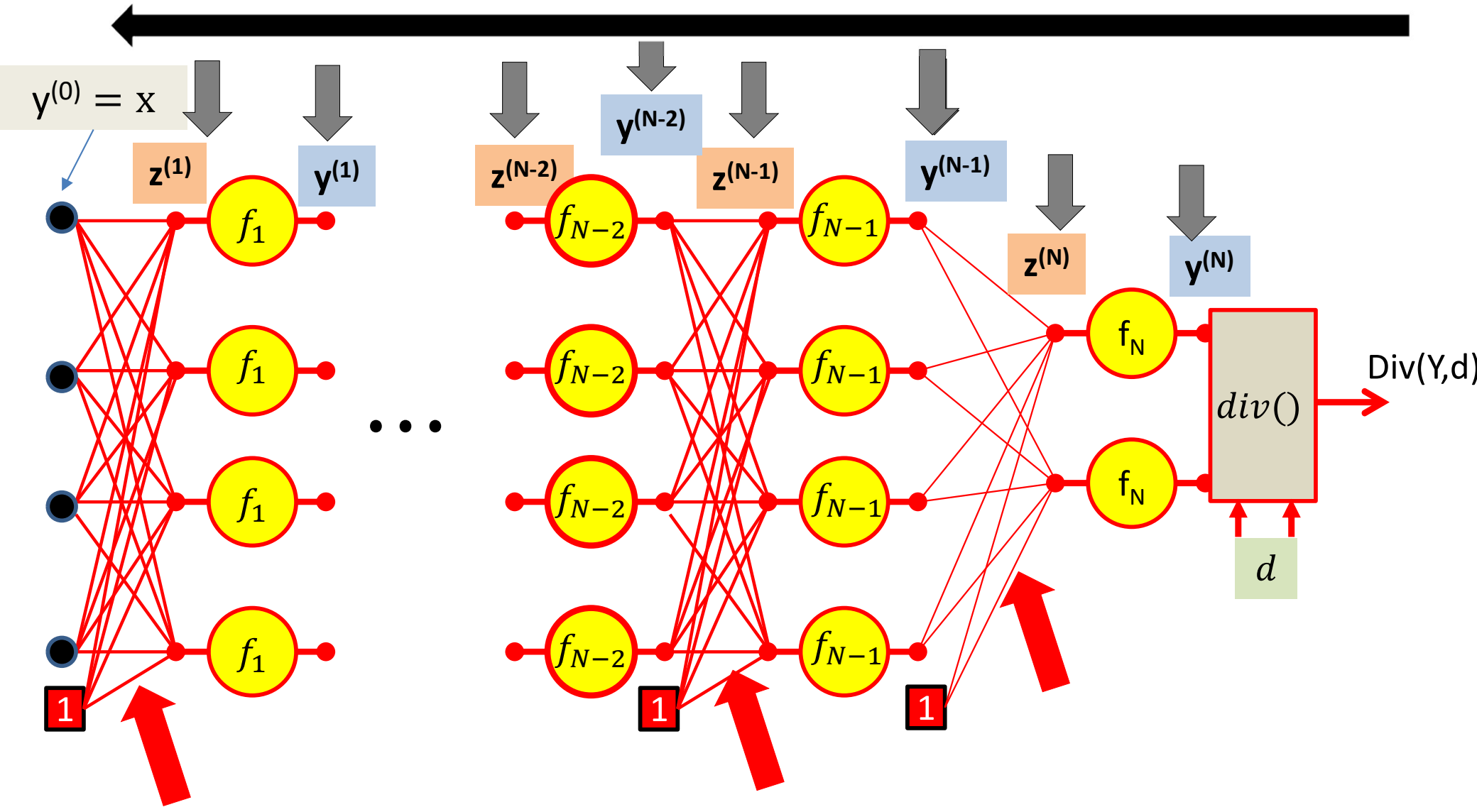

We continue our way backwards in the order shown

$$\nabla_{W^{(1)}} div(.)$$

Backward Gradient Computation

- Let's actually see the math..

Computing derivatives

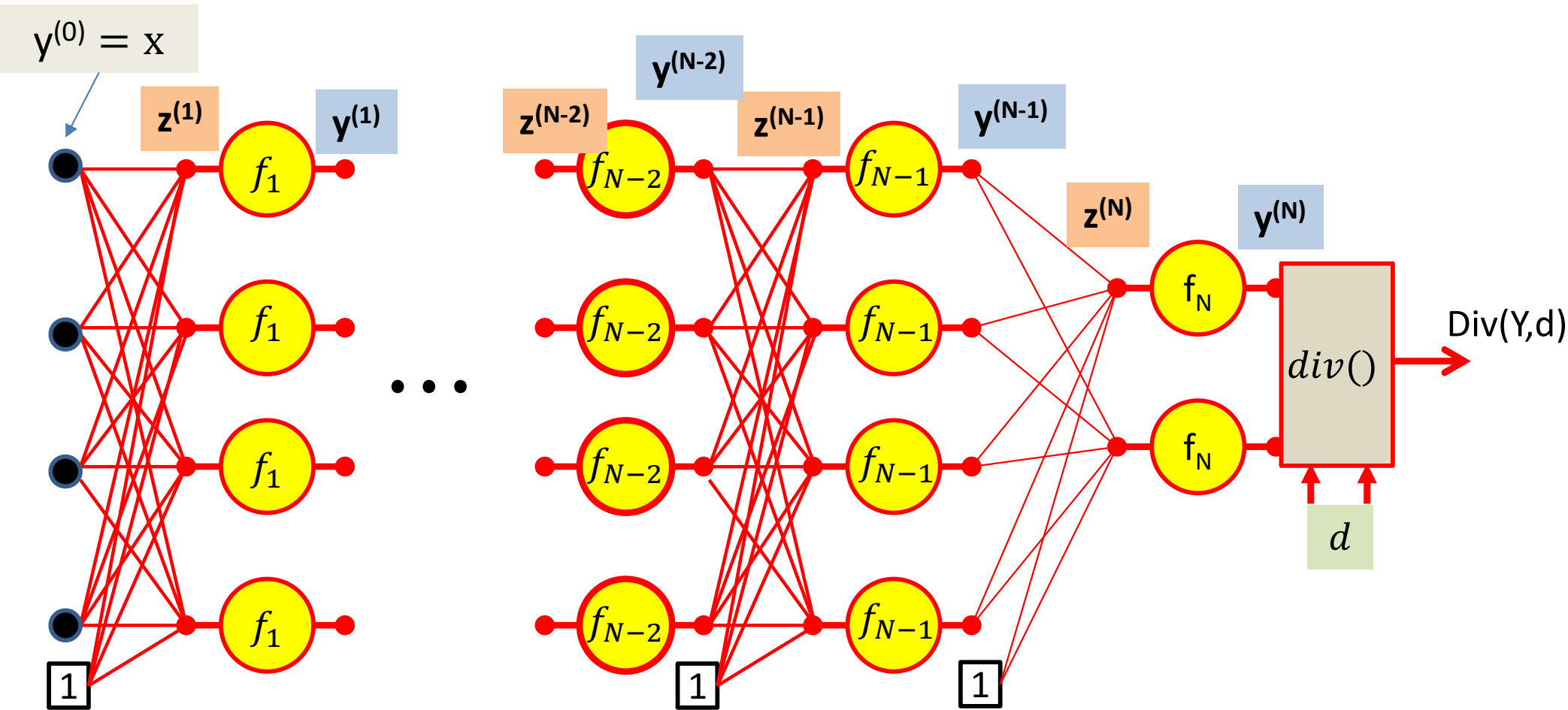

Computing derivatives

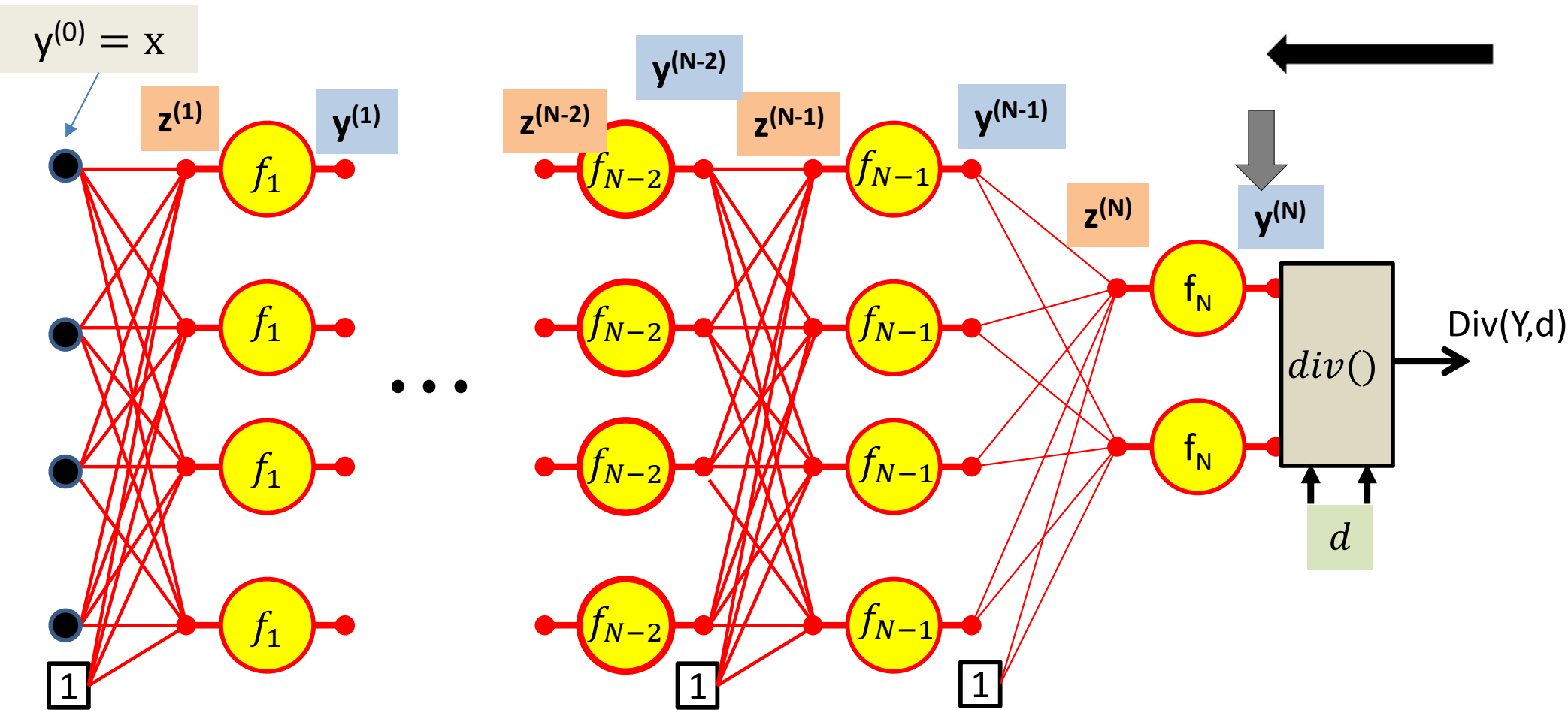

The derivative w.r.t the actual output of the final layer of the network is simply the derivative w.r.t to the output of the network

$$\frac{\partial Div(Y, d)}{\partial y_i^{(N)}} = \frac{\partial Div(Y, d)}{\partial y_i}$$

Calculus Refresher: Chain rule

For any nested function $l = f(y)$ where $y = g(z)$

$$\frac{dl}{dz} = \frac{dl}{dy} \frac{dy}{dz}$$

$$\frac{dl}{dz} = \frac{dl}{dy} \frac{dy}{dz}$$



Computing derivatives

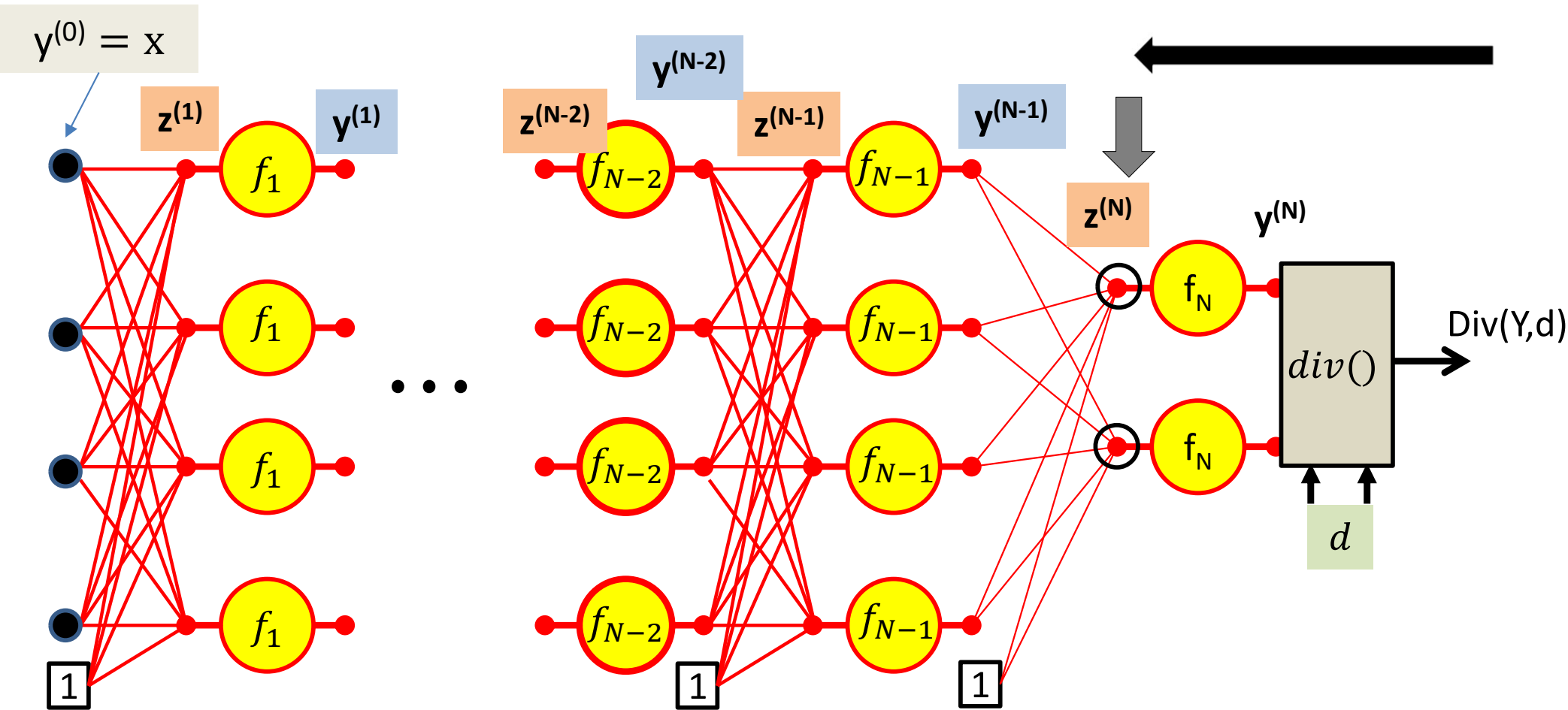

$$\frac{\partial Div}{\partial z_i^{(N)}} = \frac{\partial y_i^{(N)}}{\partial z_i^{(N)}} \frac{\partial Div}{\partial y_i^{(N)}}$$

Computing derivatives

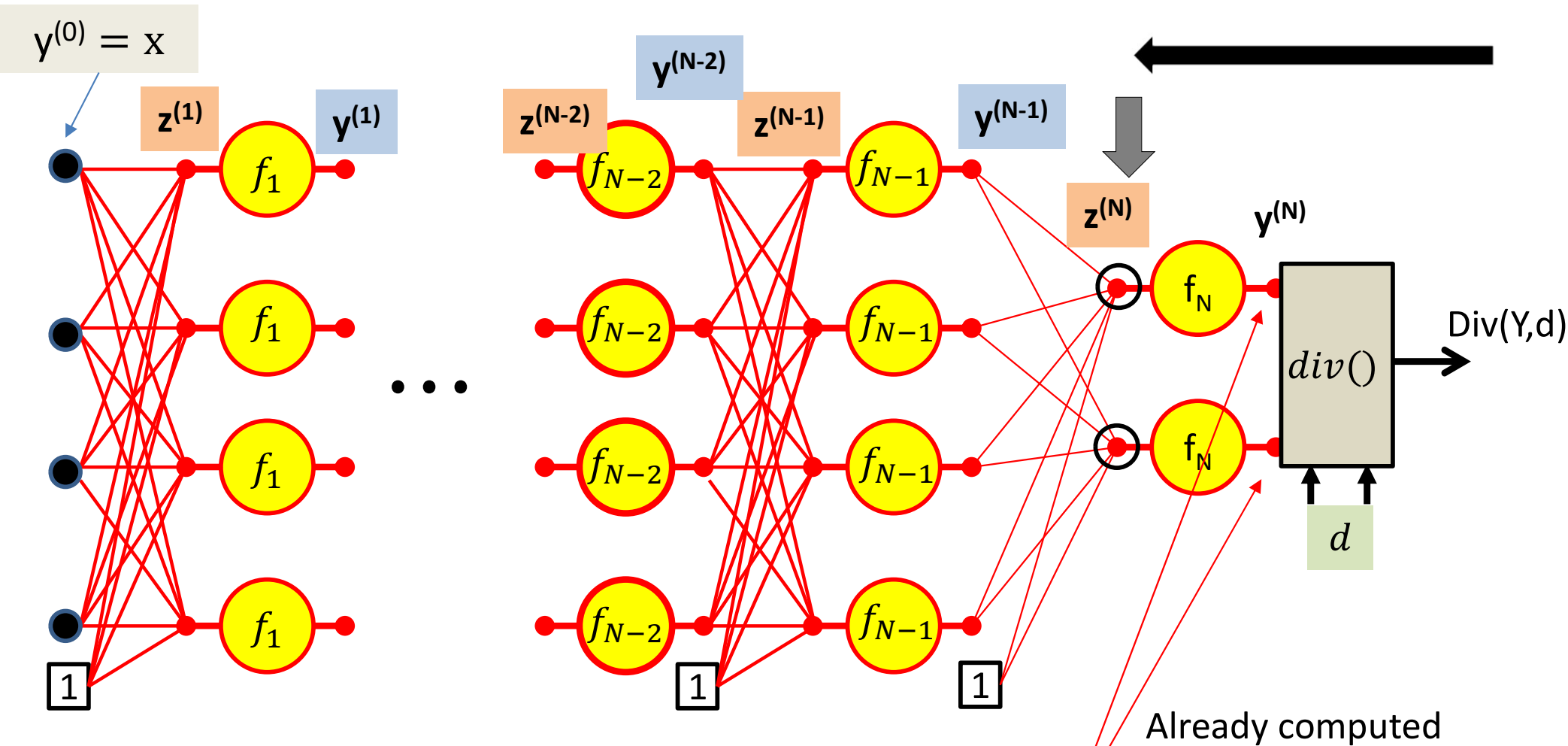

$$\frac{\partial Div}{\partial z_i^{(N)}} = \frac{\partial y_i^{(N)}}{\partial z_i^{(N)}} \frac{\partial Div}{\partial y_i^{(N)}}$$

Computing derivatives

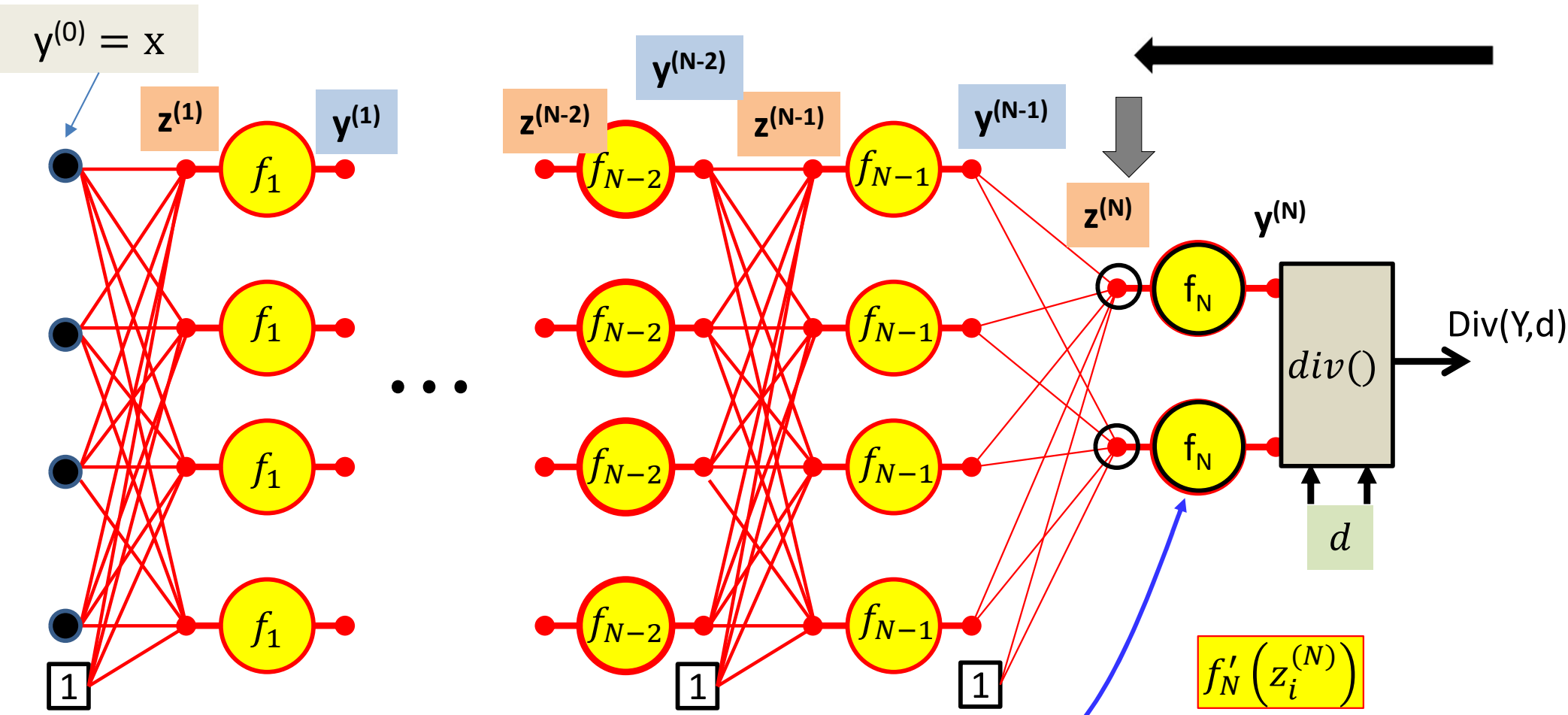

$$\frac{\partial Div}{\partial z_i^{(N)}} = \frac{\partial y_i^{(N)}}{\partial z_i^{(N)}} \frac{\partial Div}{\partial y_i^{(N)}}$$

Derivative of activation function

Computing derivatives

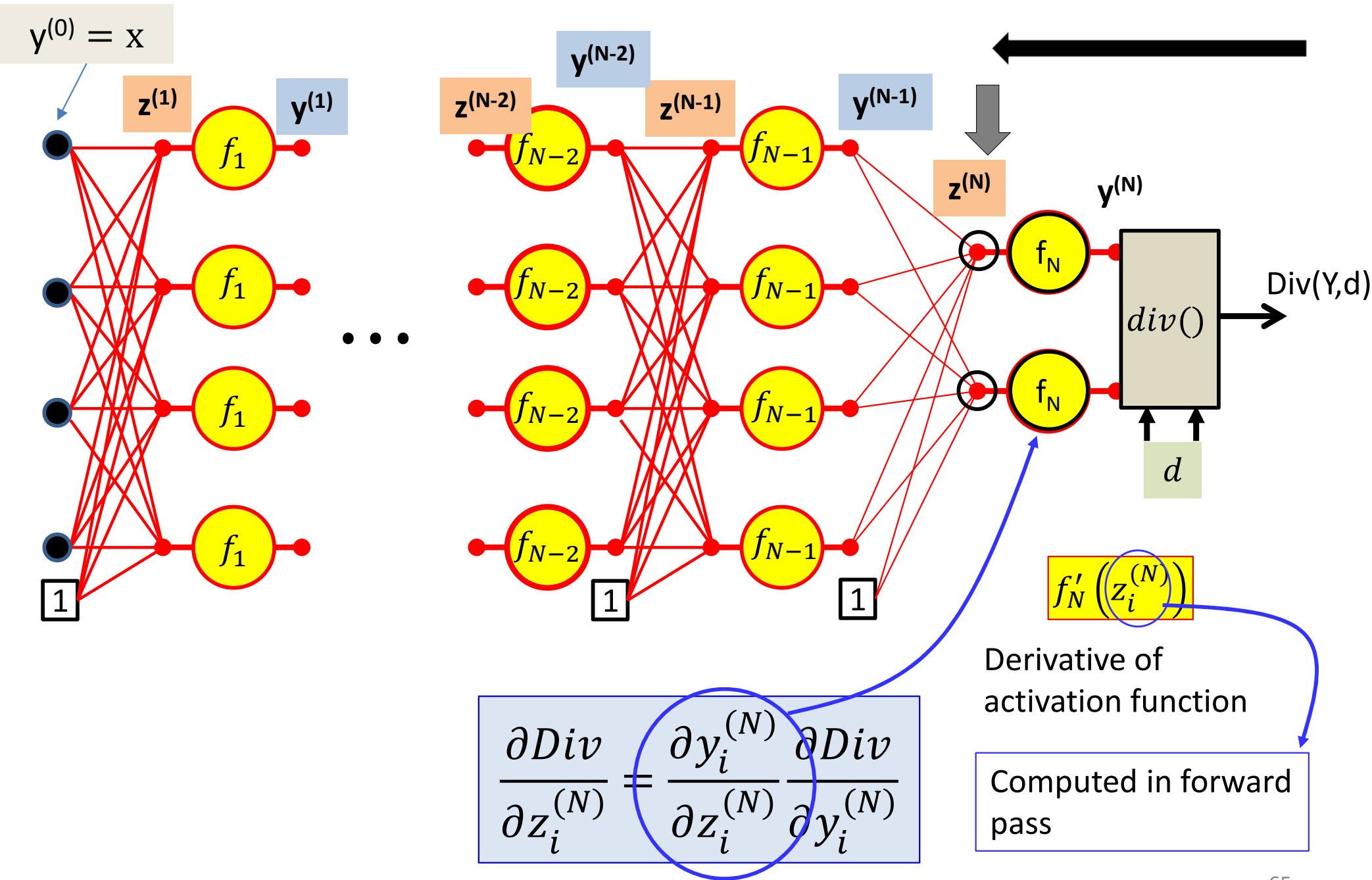

$$\frac{\partial Div}{\partial z_i^{(N)}} = \frac{\partial y_i^{(N)}}{\partial z_i^{(N)}} \frac{\partial Div}{\partial y_i^{(N)}}$$

Computing derivatives

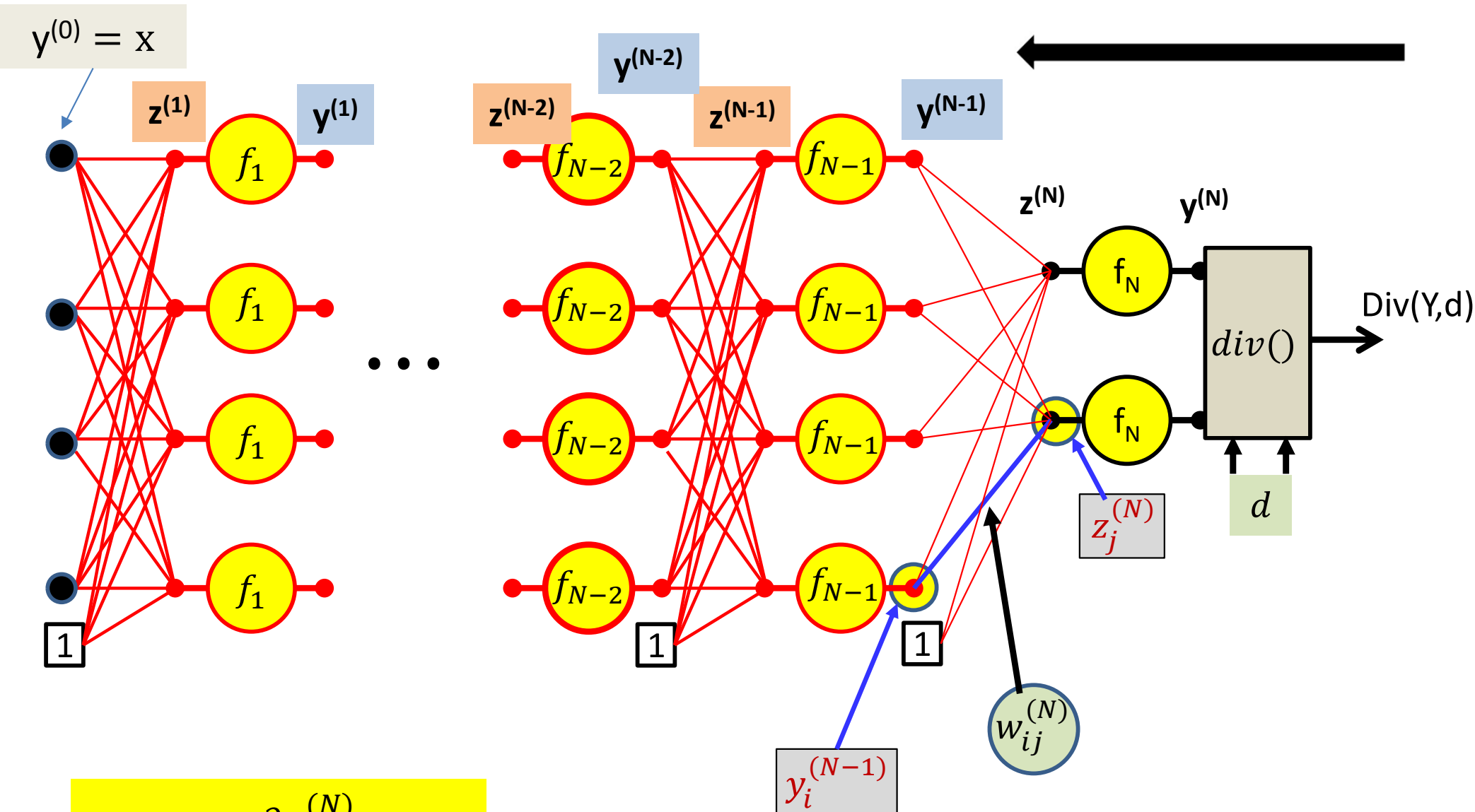

$$\frac{\partial Div}{\partial w_{ij}^{(N)}} = \frac{\partial z_j^{(N)}}{\partial w_{ij}^{(N)}} \frac{\partial Div}{\partial z_j^{(N)}}$$

Computing derivatives

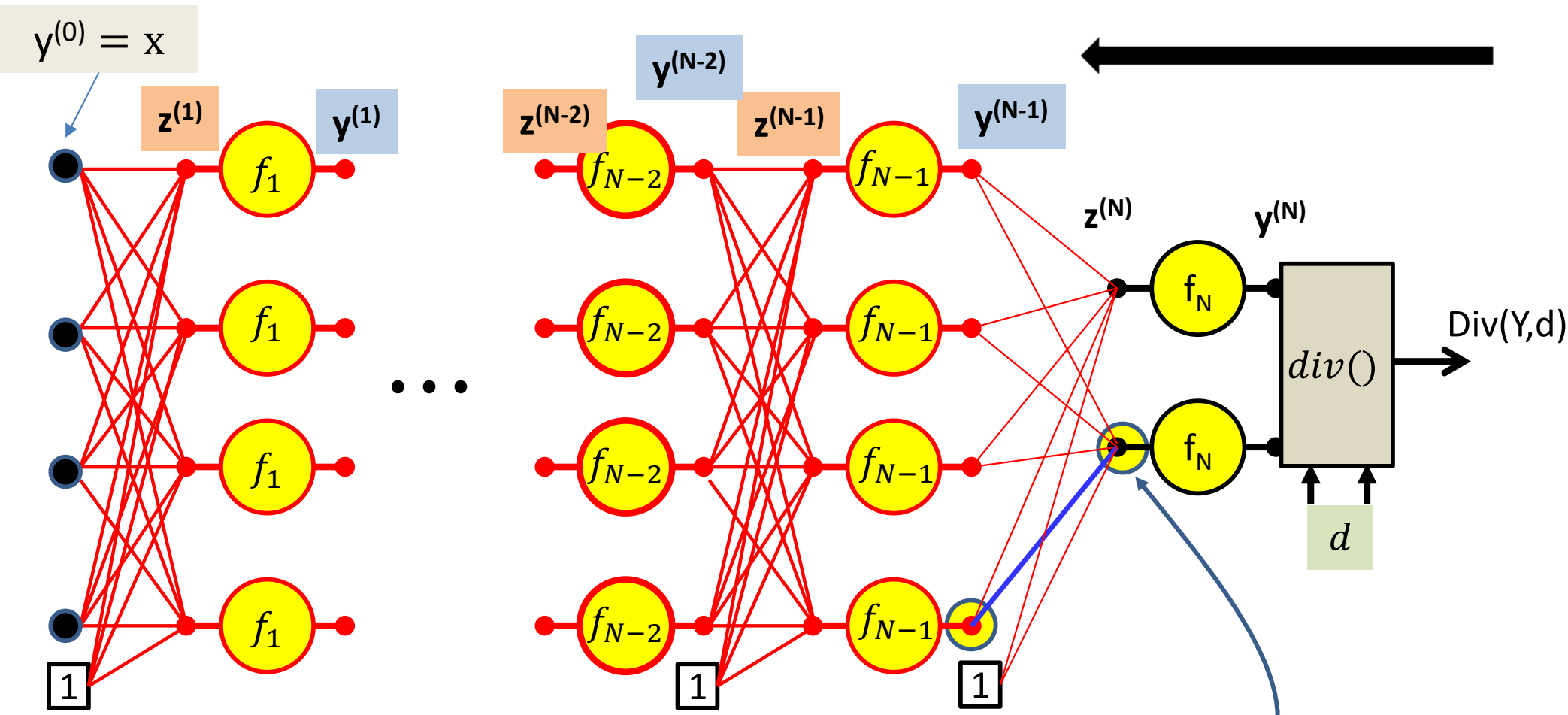

$$\frac{\partial Div}{\partial w_{ij}^{(N)}} = \frac{\partial z_j^{(N)}}{\partial w_{ij}^{(N)}} \frac{\partial Div}{\partial z_j^{(N)}}$$

Just computed

Computing derivatives

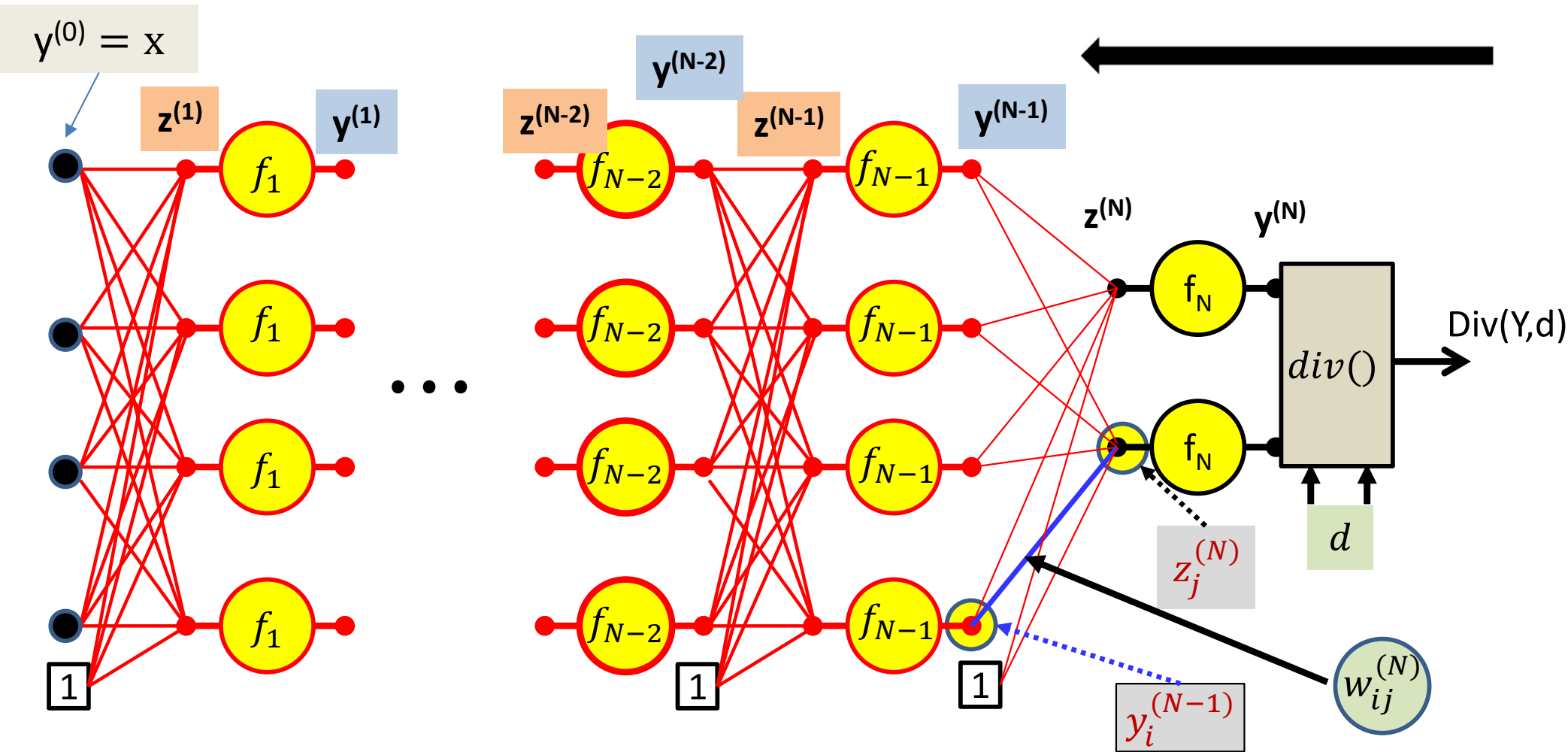

$$\frac{\partial \text{Div}}{\partial w_{ij}^{(N)}} = \frac{\partial z_j^{(N)}}{\partial w_{ij}^{(N)}} \frac{\partial \text{Div}}{\partial z_j^{(N)}}$$

$y_i^{(N-1)}$

Because $z_j^{(N)} = w_{ij}^{(N)} y_i^{(N-1)} + \text{other terms}$

Computing derivatives

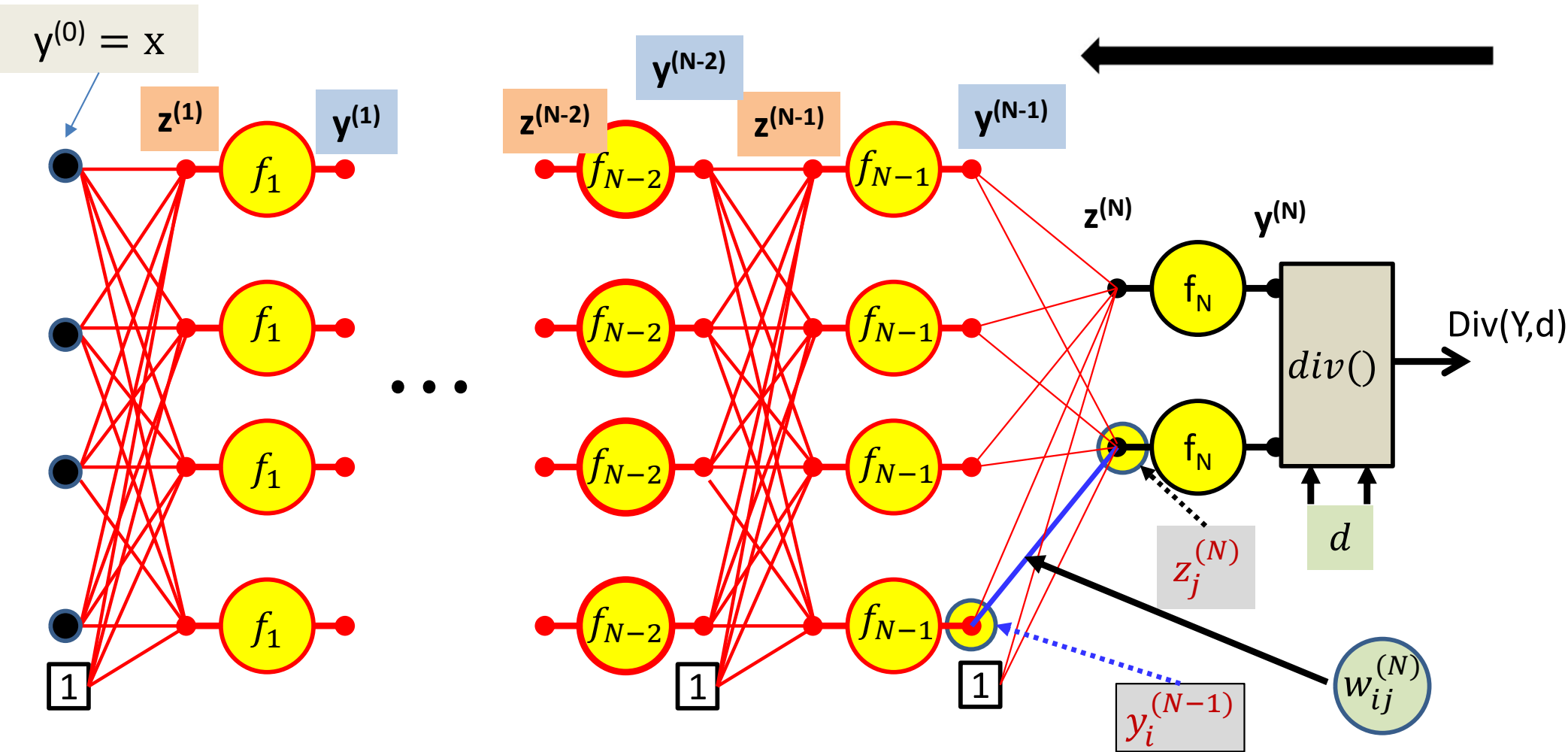

$$\frac{\partial \text{Div}}{\partial w_{ij}^{(N)}} = \frac{\partial z_j^{(N)}}{\partial w_{ij}^{(N)}} \frac{\partial \text{Div}}{\partial z_j^{(N)}}$$

Because $z_j^{(N)} = w_{ij}^{(N)} y_i^{(N-1)} + \text{other terms}$

Computed in forward pass

Computing derivatives

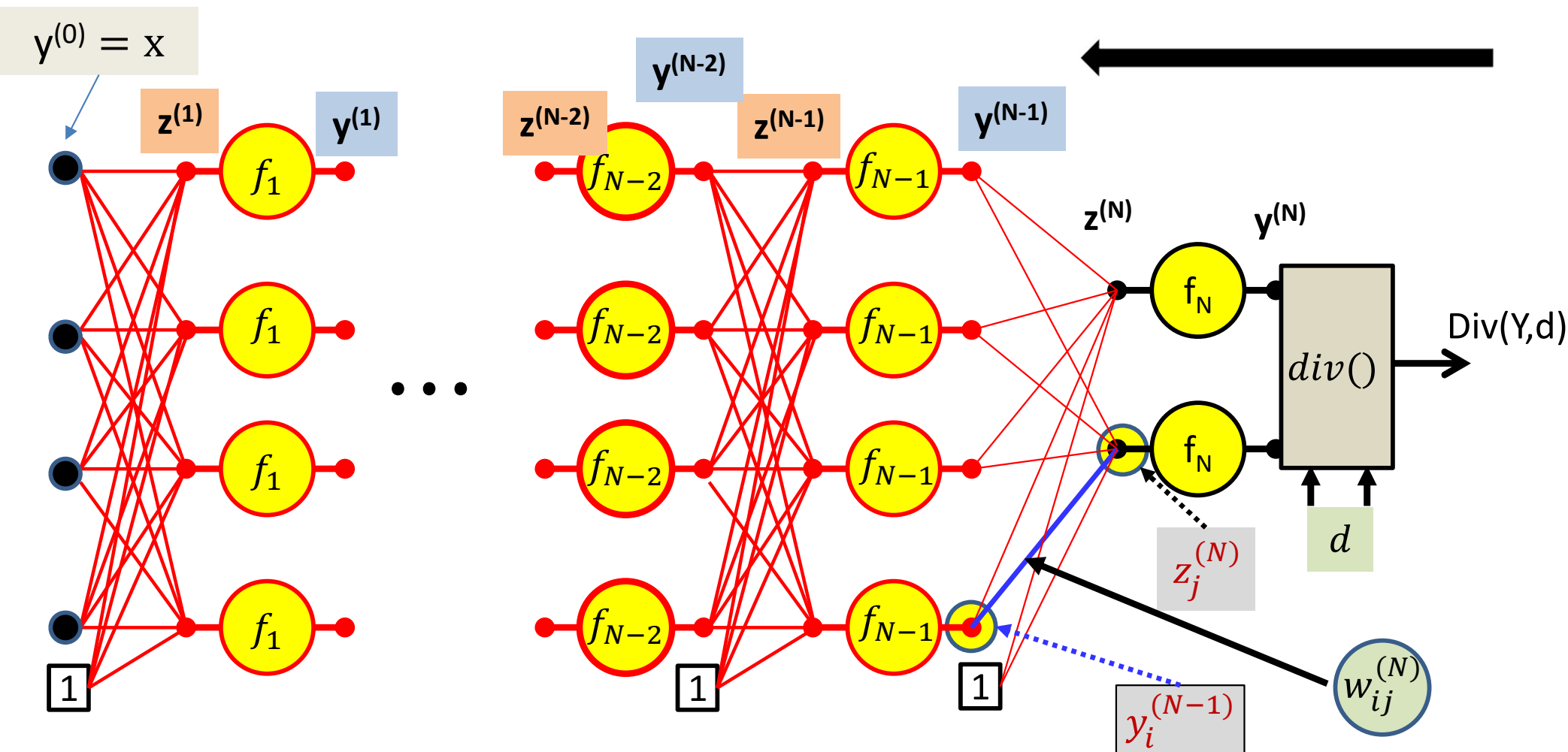

$$\frac{\partial Div}{\partial w_{ij}^{(N)}} = y_i^{(N-1)} \frac{\partial Div}{\partial z_j^{(N)}}$$

Computing derivatives

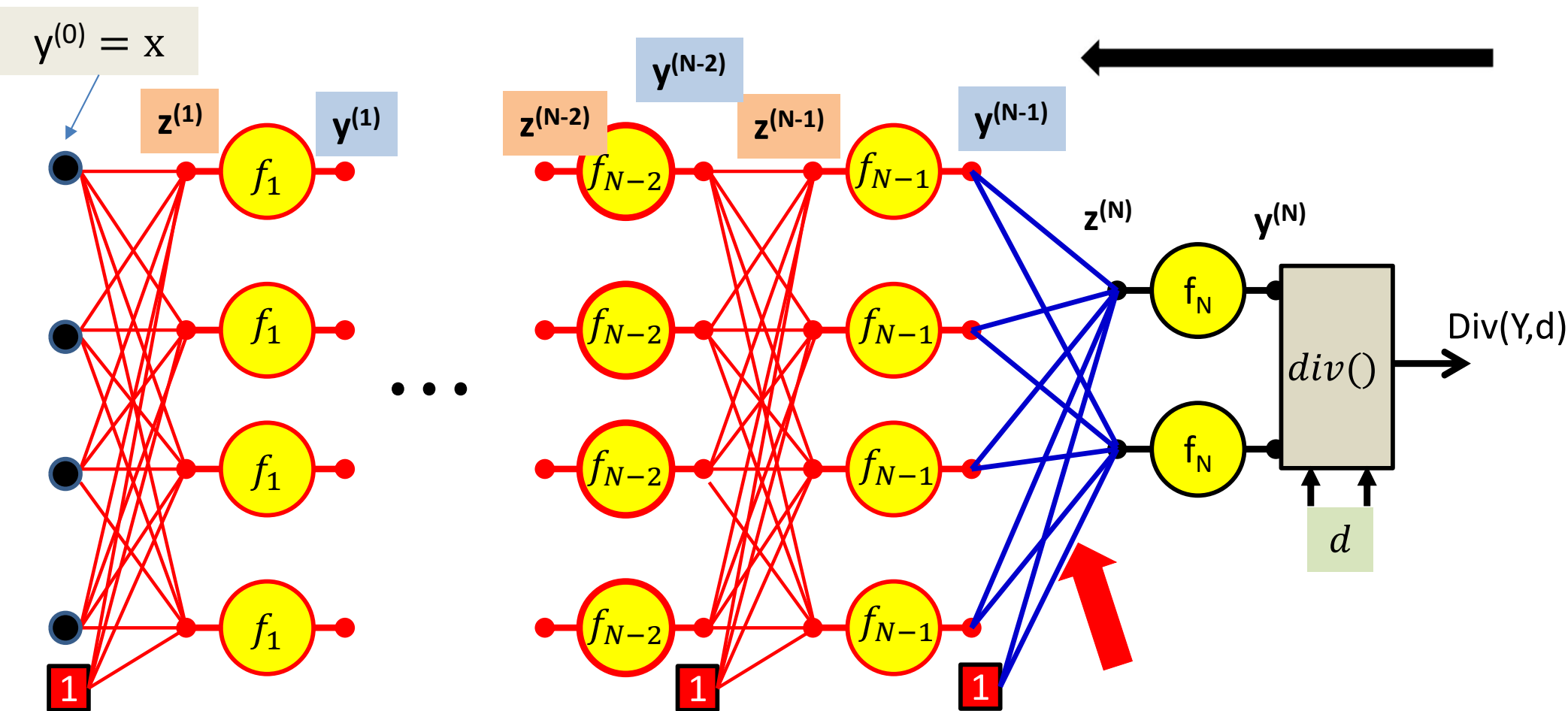

$$\frac{\partial Div}{\partial w_{ij}^{(N)}} = y_i^{(N-1)} \frac{\partial Div}{\partial z_j^{(N)}}$$

For the bias term $y_0^{(N-1)} = 1$

Calculus Refresher: Chain rule

For $l = f(z_1, z_2, \dots, z_M)$
where $z_i = g_i(x)$

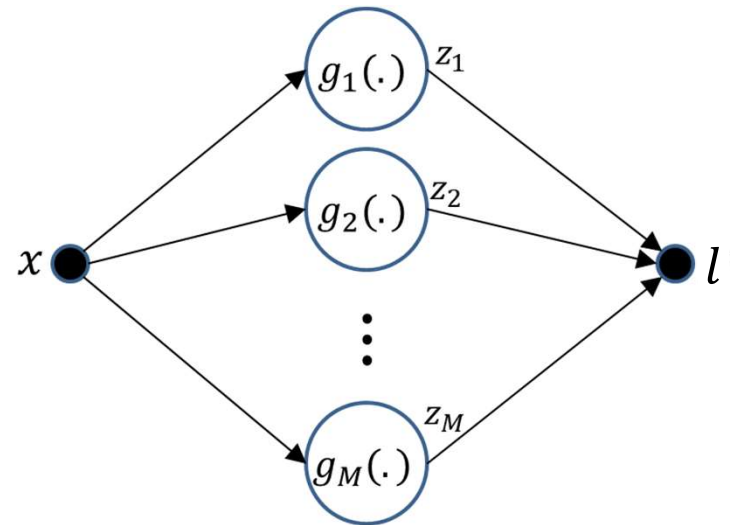

$$\frac{dl}{dx} = \frac{\partial l}{\partial z_1} \frac{dz_1}{dx} + \frac{\partial l}{\partial z_2} \frac{dz_2}{dx} + \dots + \frac{\partial l}{\partial z_M} \frac{dz_M}{dx}$$

Computing derivatives

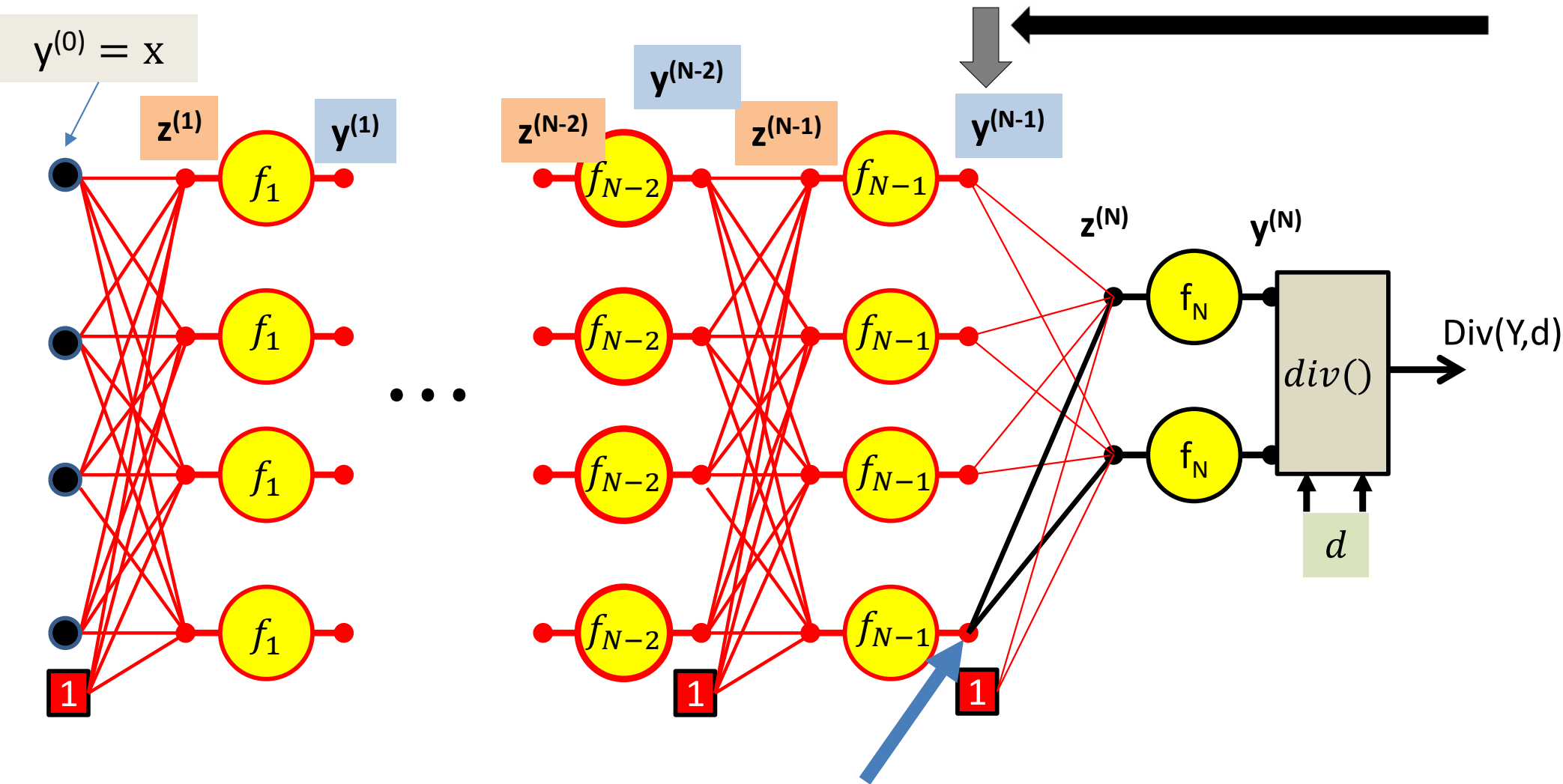

$$\frac{\partial Div}{\partial y_i^{(N-1)}} = \sum_j \frac{\partial z_j^{(N)}}{\partial y_i^{(N-1)}} \frac{\partial Div}{\partial z_j^{(N)}}$$

Computing derivatives

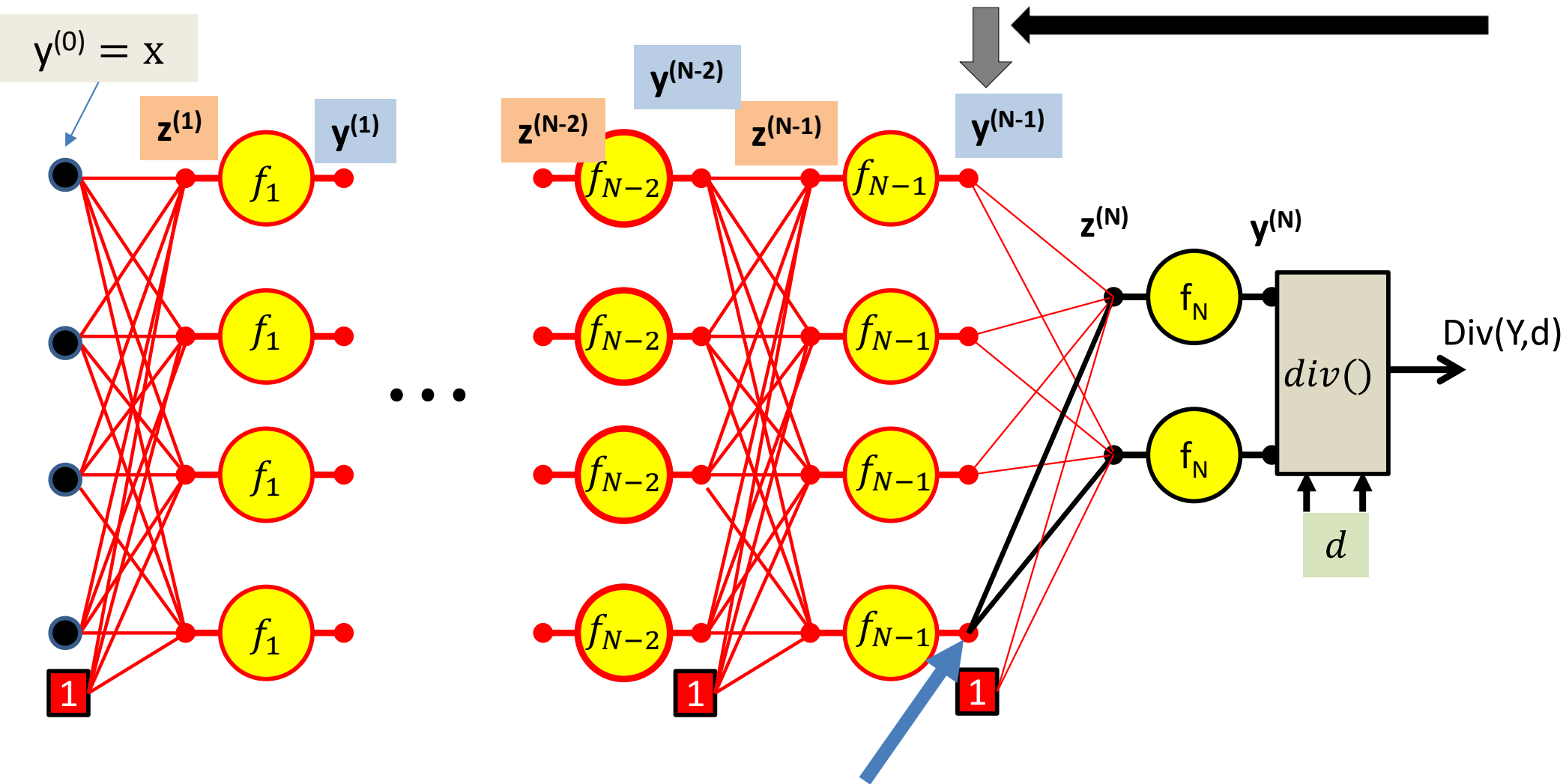

$$\frac{\partial Div}{\partial y_i^{(N-1)}} = \sum_j \frac{\partial z_j^{(N)}}{\partial y_i^{(N-1)}} \frac{\partial Div}{\partial z_j^{(N)}}$$

$y_i^{(N-1)}$
Already computed

Computing derivatives

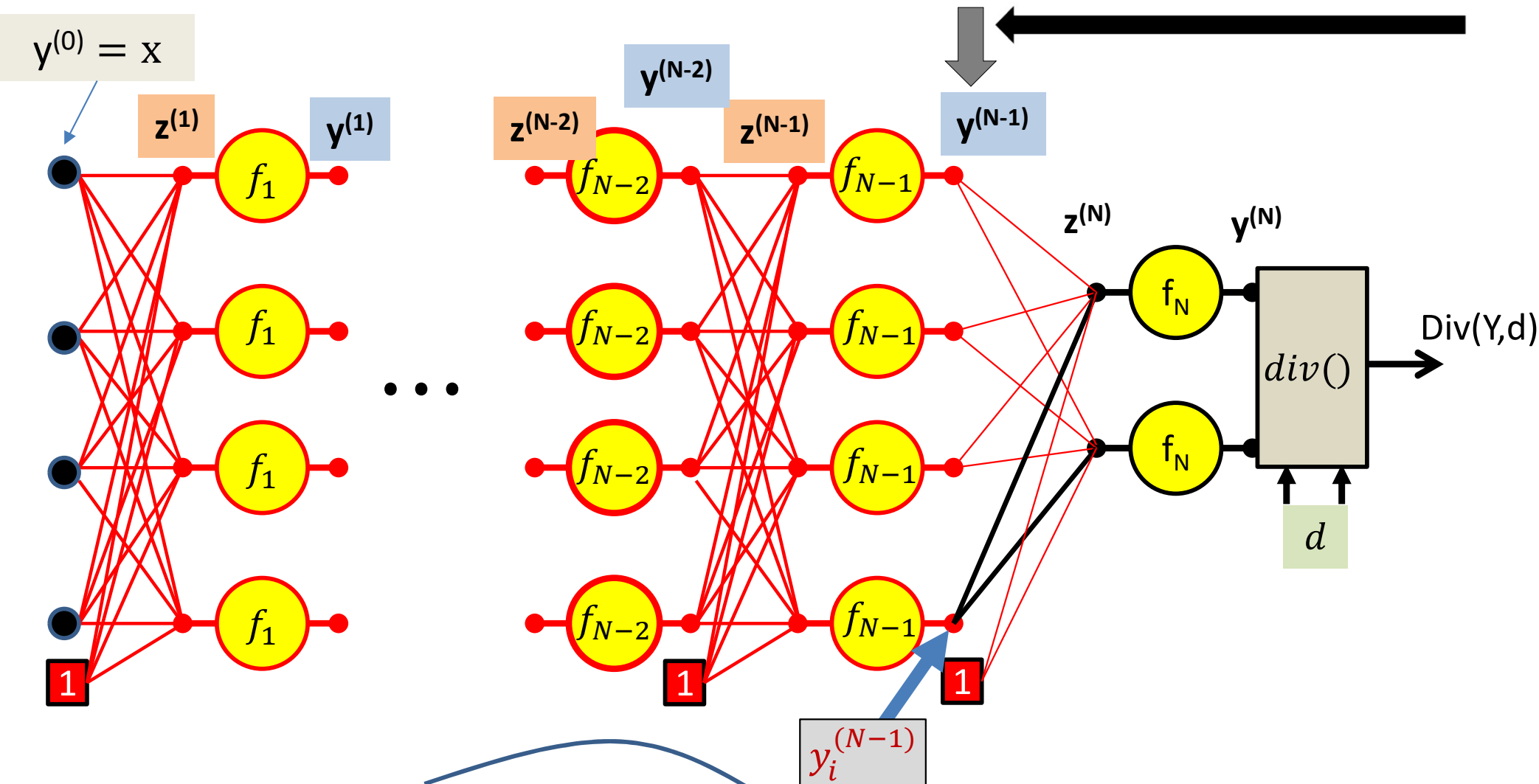

$$\frac{\partial \text{Div}}{\partial y_i^{(N-1)}} = \sum_j \frac{\partial z_j^{(N)}}{\partial y_i^{(N-1)}} \frac{\partial \text{Div}}{\partial z_j^{(N)}}$$

$y_i^{(N-1)}$
 $w_{ij}^{(N)}$

Because $z_j^{(N)} = w_{ij}^{(N)} y_i^{(N-1)} + \text{other terms}$

Computing derivatives

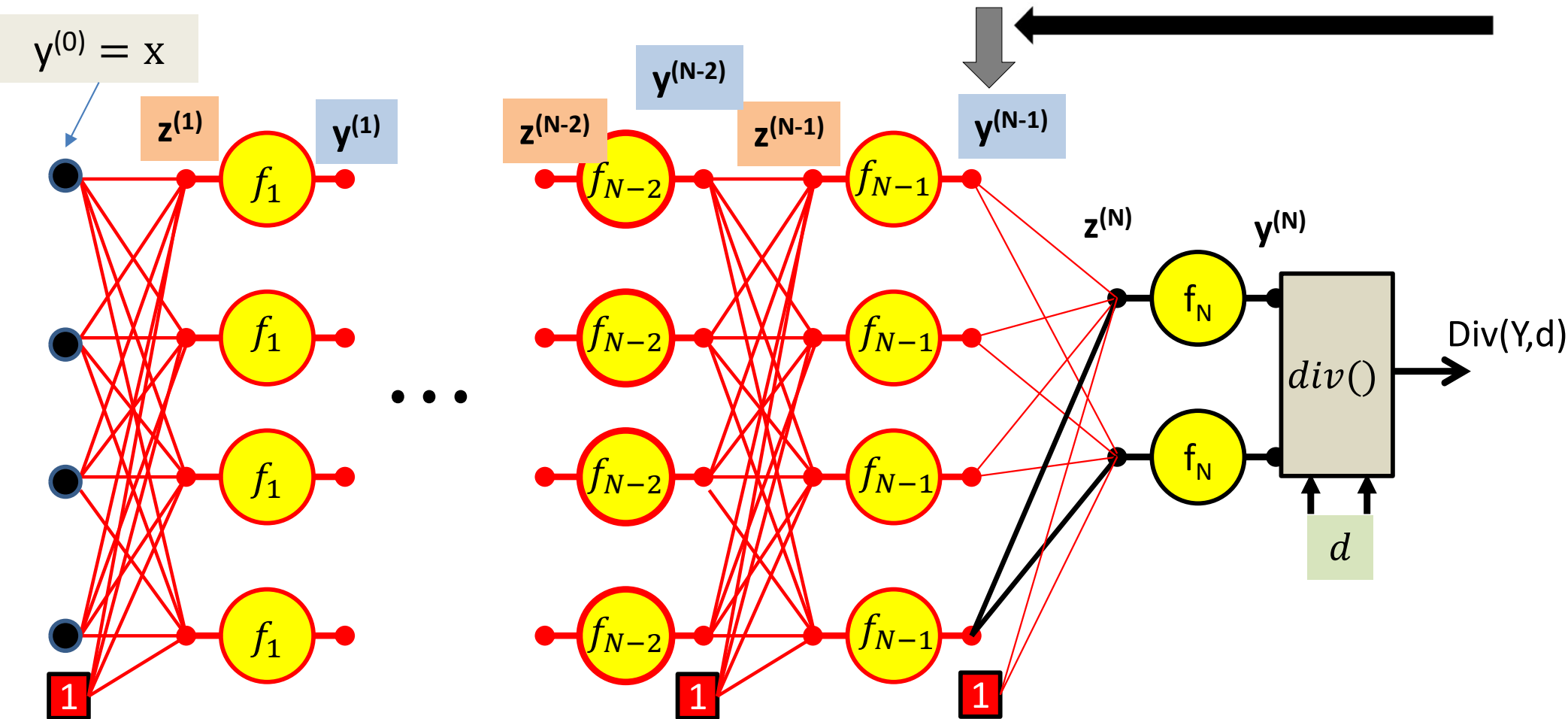

$$\frac{\partial Div}{\partial y_i^{(N-1)}} = \sum_j w_{ij}^{(N)} \frac{\partial Div}{\partial z_j^{(N)}}$$

Computing derivatives

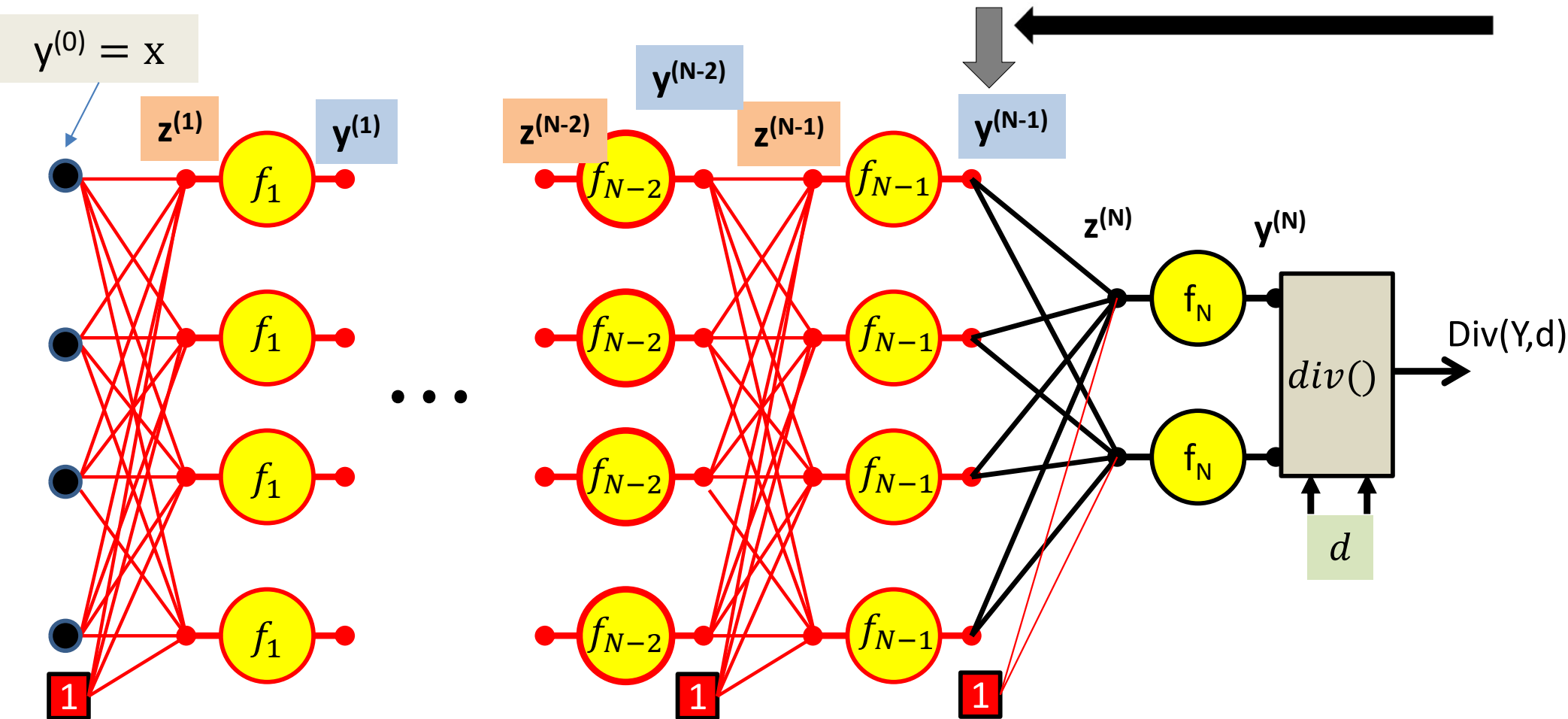

$$\frac{\partial Div}{\partial y_i^{(N-1)}} = \sum_j w_{ij}^{(N)} \frac{\partial Div}{\partial z_j^{(N)}}$$

Computing derivatives

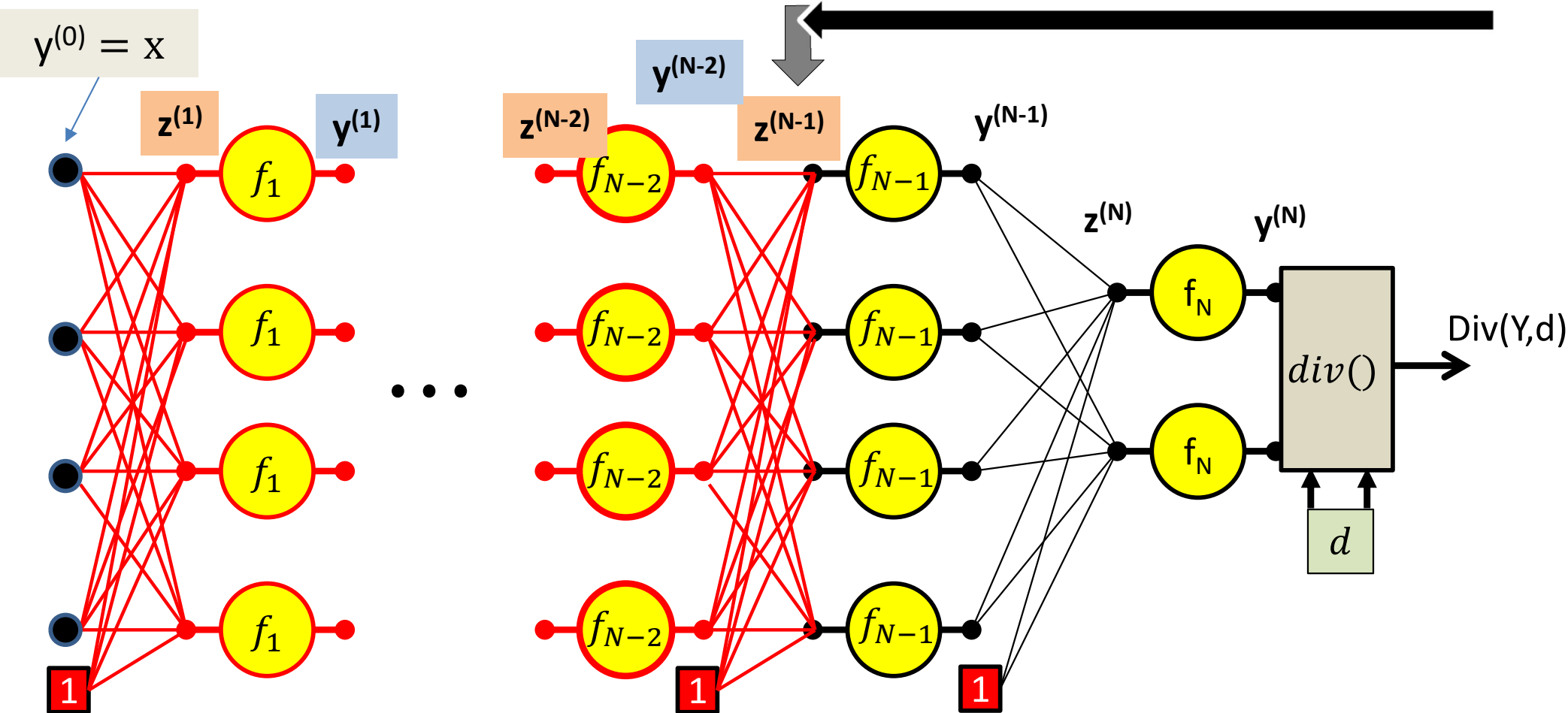

We continue our way backwards in the order shown

$$\frac{\partial \text{Div}}{\partial z_i^{(N-1)}} = f'_{N-1} \left(z_i^{(N-1)} \right) \frac{\partial \text{Div}}{\partial y_i^{(N-1)}}$$

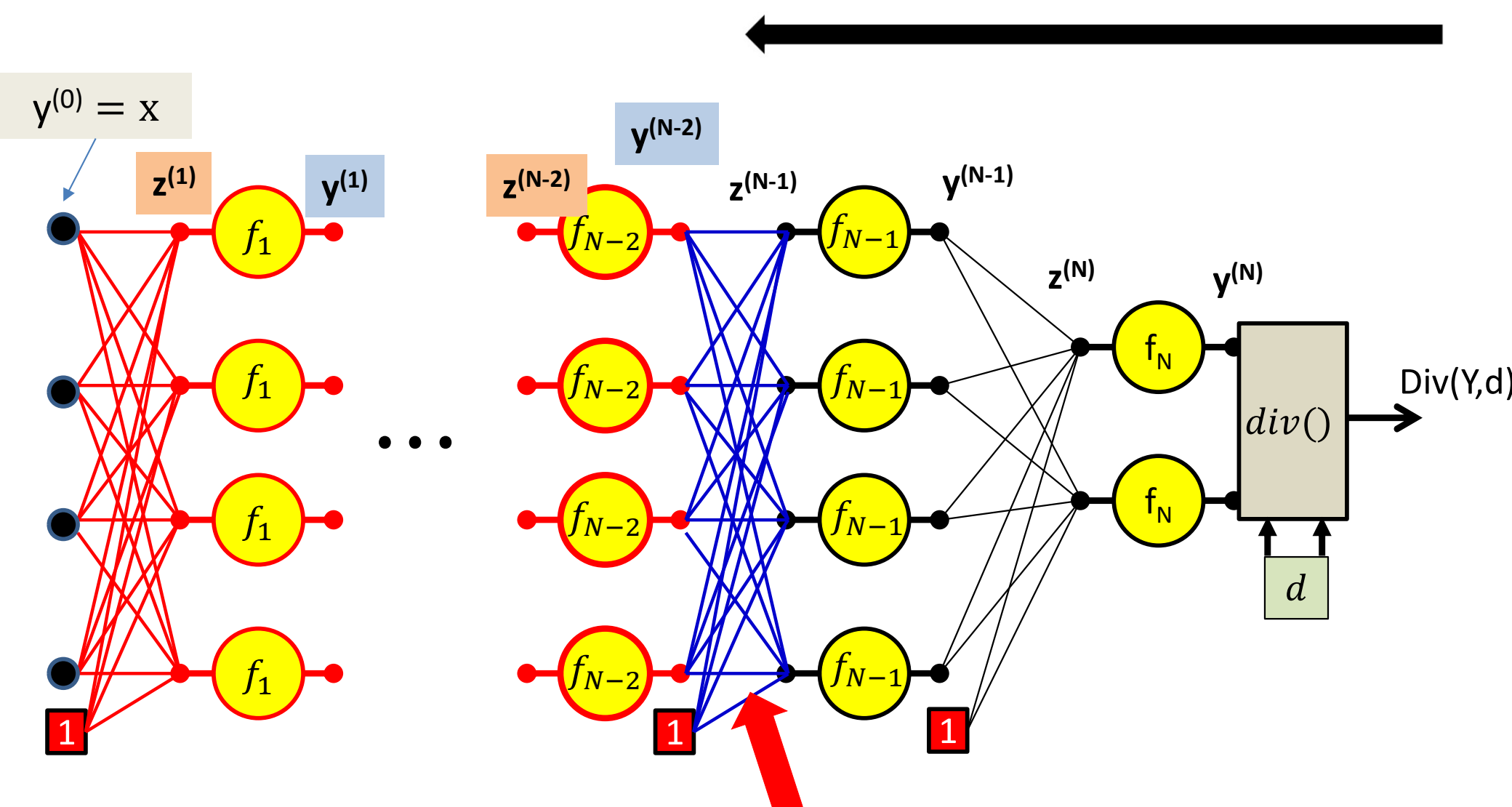

We continue our way backwards in the order shown

$$\frac{\partial Div}{\partial w_{ij}^{(N-1)}} = y_i^{(N-2)} \frac{\partial Div}{\partial z_j^{(N-1)}}$$

For the bias term $y_0^{(N-2)} = 1$

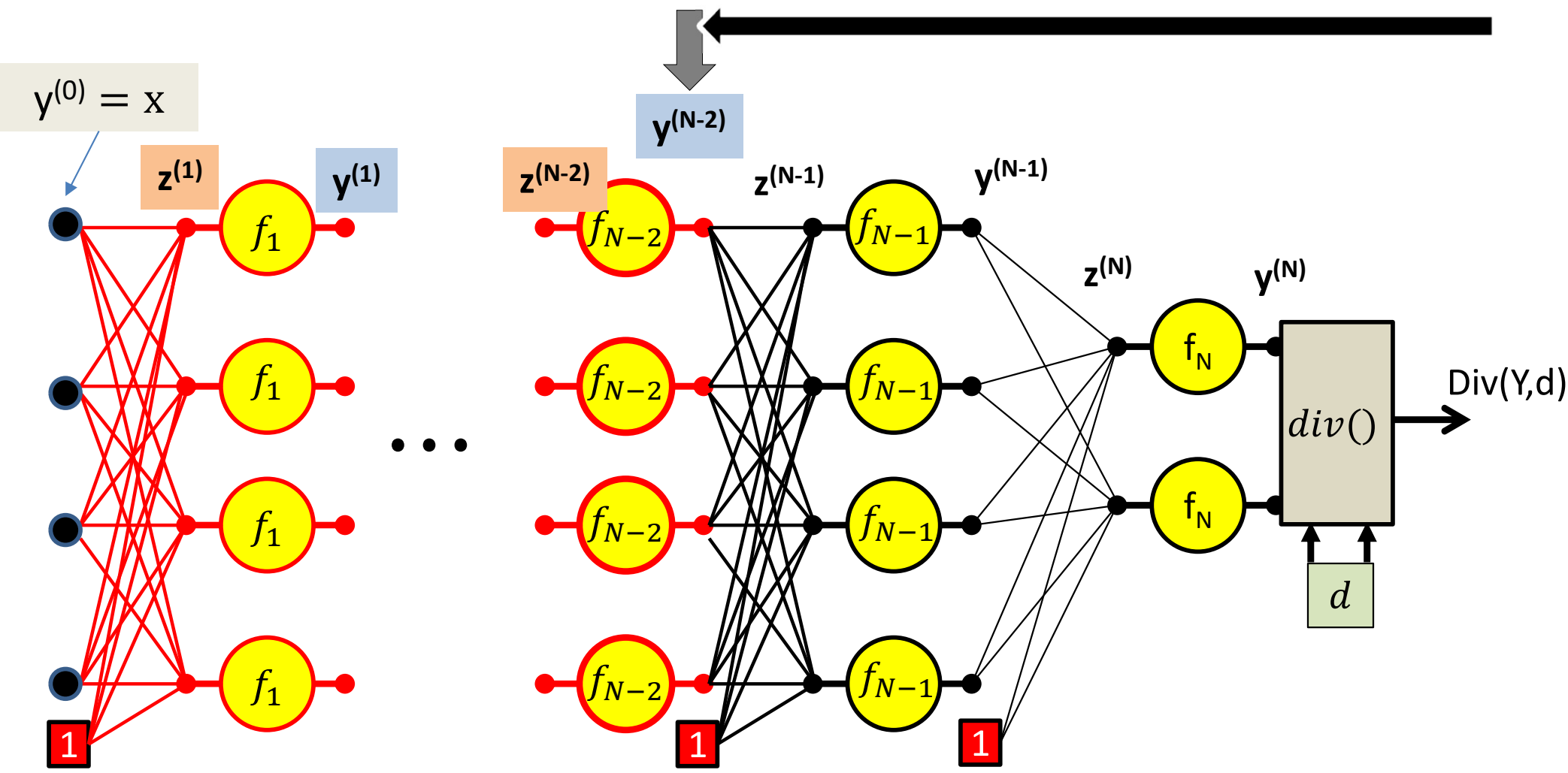

We continue our way backwards in the order shown

$$\frac{\partial Div}{\partial y_i^{(N-2)}} = \sum_j w_{ij}^{(N-1)} \frac{\partial Div}{\partial z_j^{(N-1)}}$$

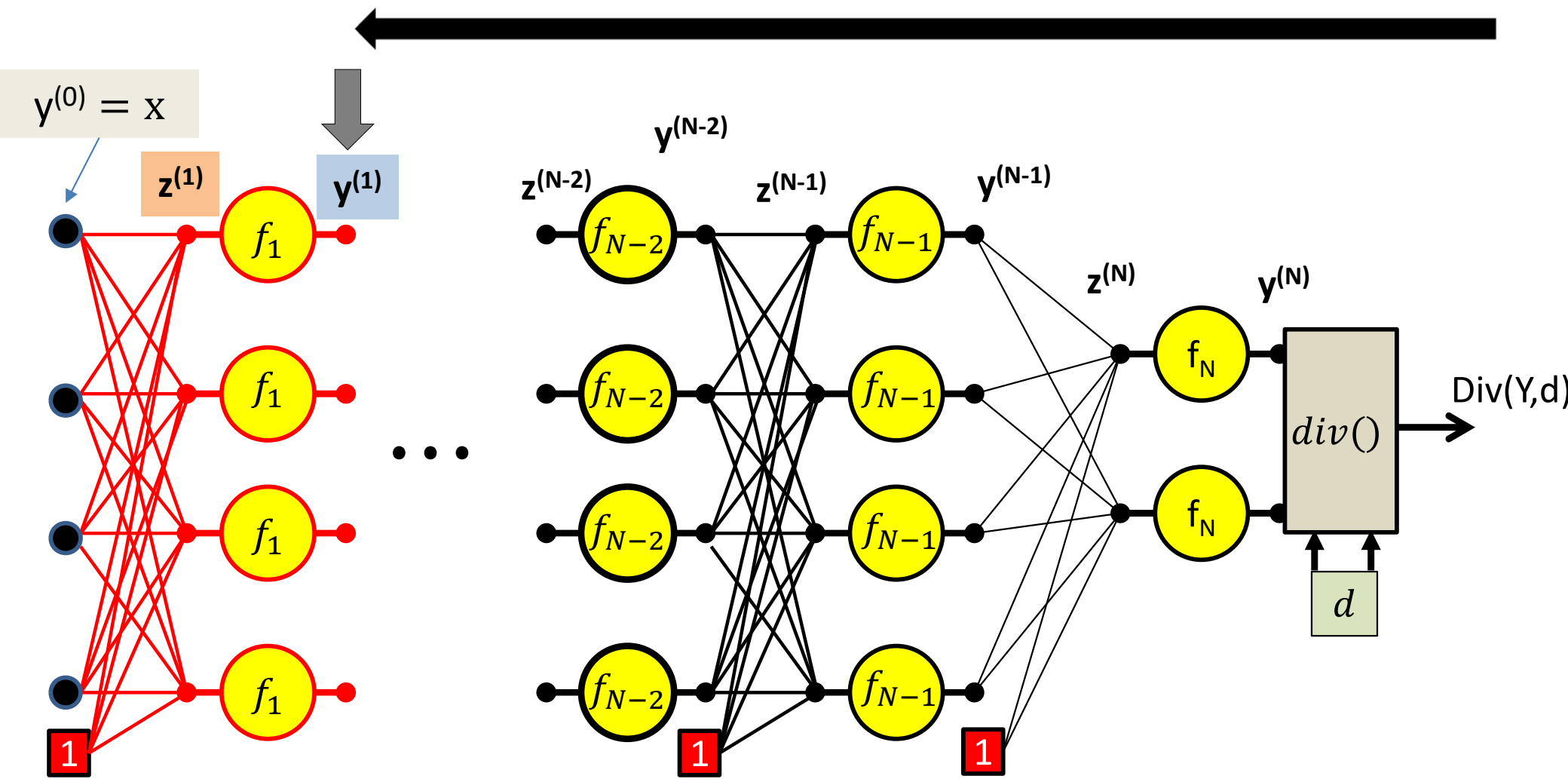

We continue our way backwards in the order shown

$$\frac{\partial Div}{\partial y_1^{(1)}} = \sum_j w_{ij}^{(2)} \frac{\partial Div}{\partial z_j^{(2)}}$$

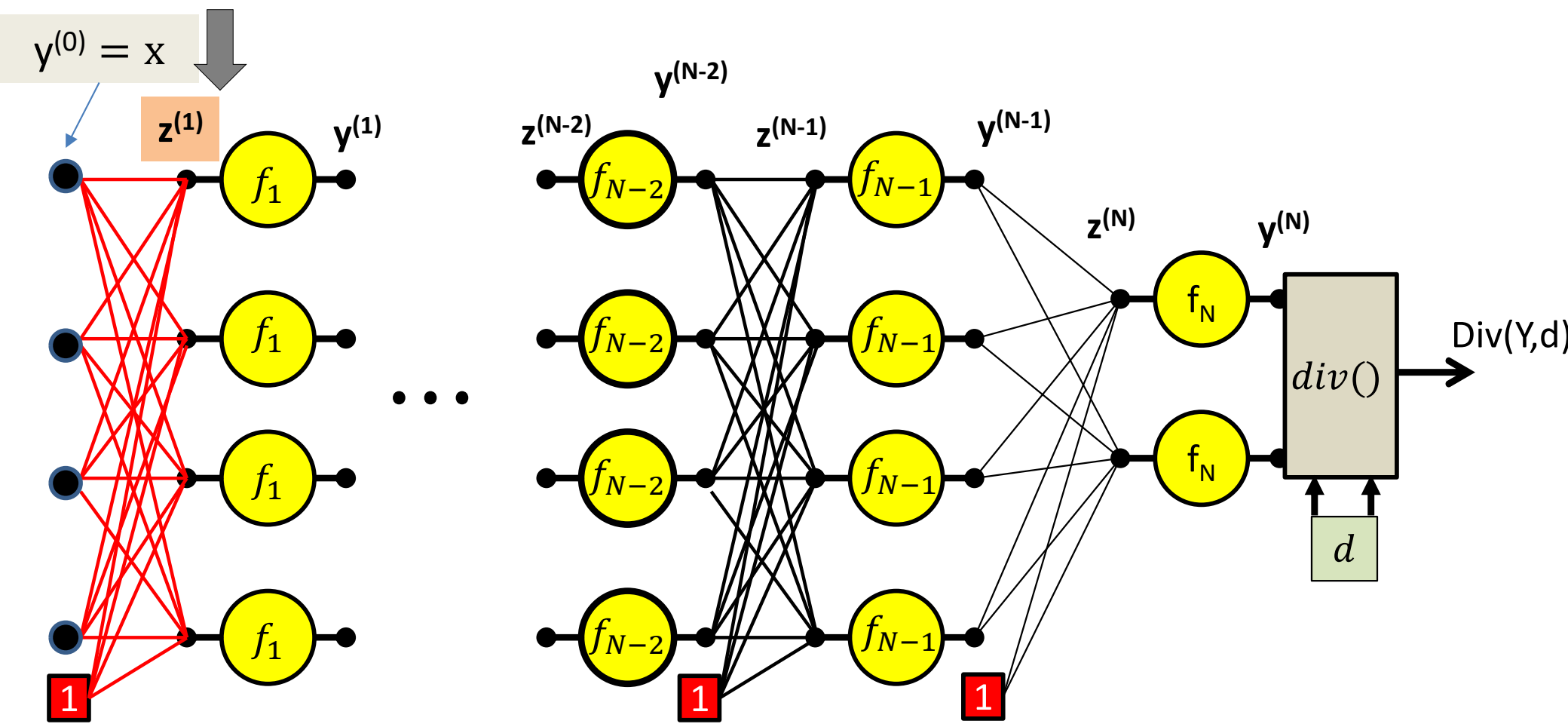

We continue our way backwards in the order shown

$$\frac{\partial Div}{\partial z_i^{(1)}} = f_1' \left(z_i^{(1)} \right) \frac{\partial Div}{\partial y_i^{(1)}}$$



$y^{(0)} = x$

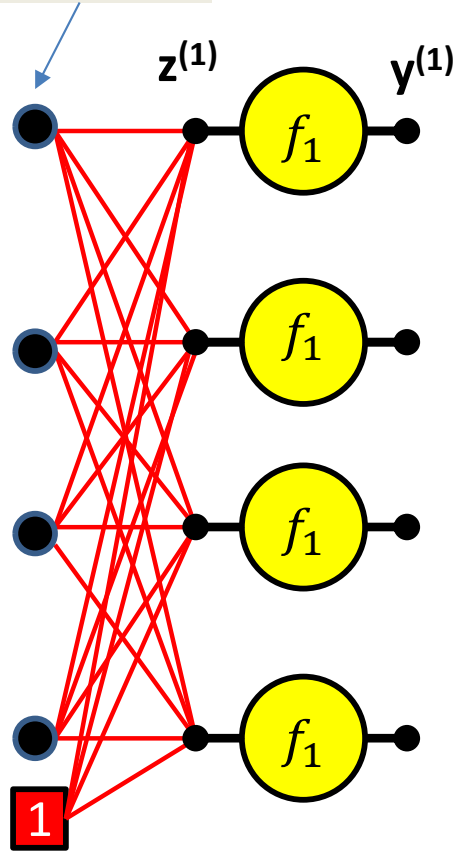

...

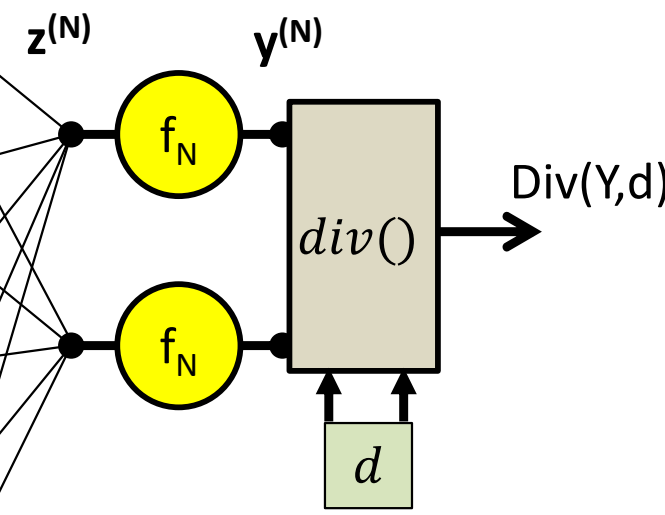
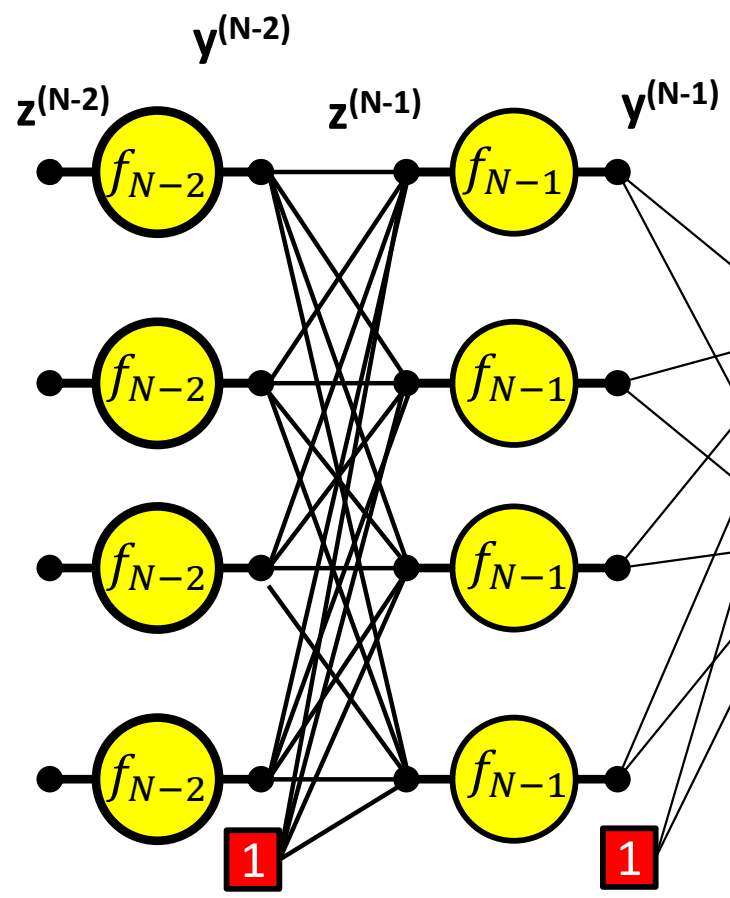

We continue our way backwards in the order shown

$$\frac{\partial Div}{\partial w_{ij}^{(1)}} = y_i^{(0)} \frac{\partial Div}{\partial z_j^{(1)}}$$

Gradients: Backward Computation

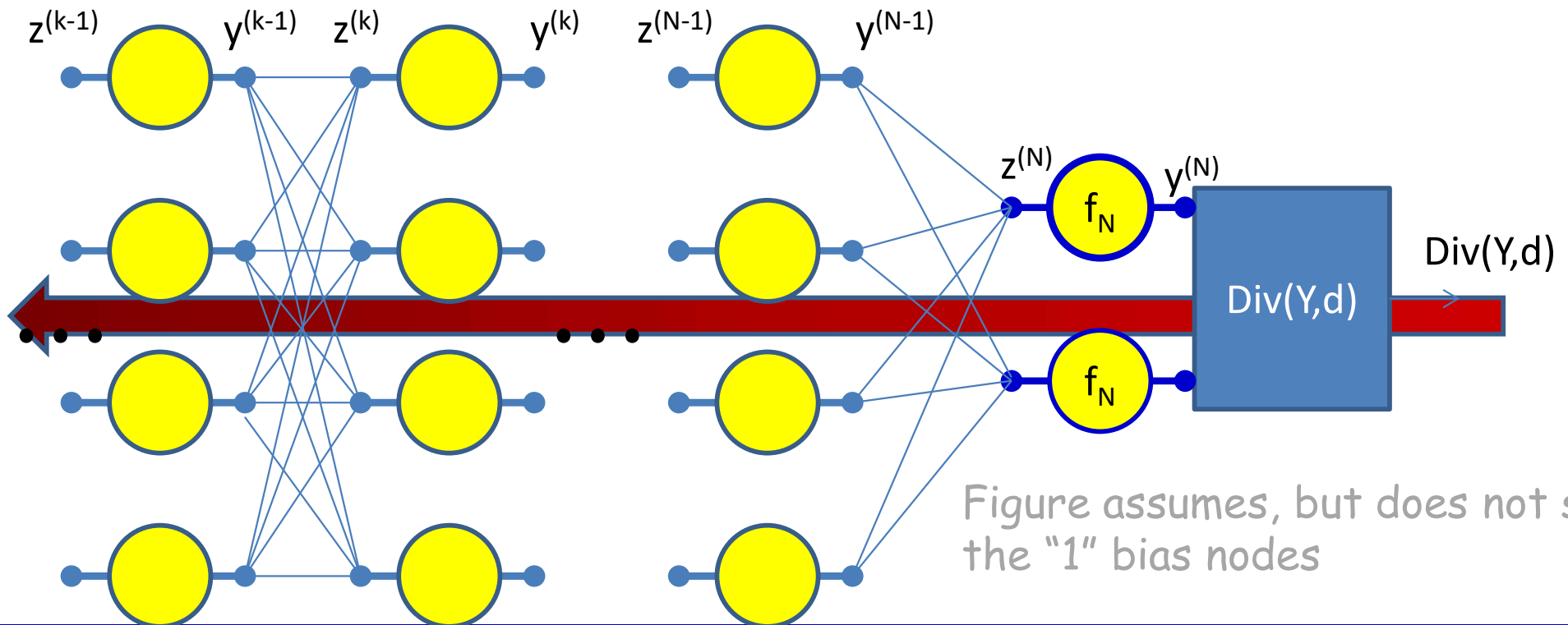

Initialize: Gradient w.r.t network output

$$\frac{\partial Div}{\partial y_i^{(N)}} = \frac{\partial Div(Y, d)}{\partial y_i}$$

$$\frac{\partial Div}{\partial z_i^{(N)}} = f'_k(z_i^{(N)}) \frac{\partial Div}{\partial y_i^{(N)}}$$

For $k = N - 1..0$

For $i = 1: \text{layer width}$

$$\frac{\partial Div}{\partial y_i^{(k)}} = \sum_j w_{ij}^{(k+1)} \frac{\partial Div}{\partial z_j^{(k+1)}}$$

$$\frac{\partial Div}{\partial z_i^{(k)}} = f'_k(z_i^{(k)}) \frac{\partial Div}{\partial y_i^{(k)}}$$

$$\forall j \frac{\partial Div}{\partial w_{ij}^{(k+1)}} = y_i^{(k)} \frac{\partial Div}{\partial z_j^{(k+1)}}$$

Backward Pass

- Output layer (N) :
 - For $i = 1 \dots D_N$
 - $\frac{\partial Div}{\partial y_i^{(N)}} = \frac{\partial Div(Y,d)}{\partial y_i}$ [This is the derivative of the divergence]
 - $\frac{\partial Div}{\partial z_i^{(N)}} = \frac{\partial Di}{\partial y_i^{(N)}} f'_N \left(z_i^{(N)} \right)$
 - $\frac{\partial Div}{\partial w_{ij}^{(N)}} = y_i^{(N-1)} \frac{\partial Div}{\partial z_j^{(N)}}$ for $j = 0 \dots D_{N-1}$
- For layer $k = N - 1$ down to 1
 - For $i = 1 \dots D_k$
 - $\frac{\partial Div}{\partial y_i^{(k)}} = \sum_j w_{ij}^{(k+1)} \frac{\partial Div}{\partial z_j^{(k+1)}}$
 - $\frac{\partial Div}{\partial z_i^{(k)}} = \frac{\partial Div}{\partial y_i^{(k)}} f'_k \left(z_i^{(k)} \right)$
 - $\frac{\partial Div}{\partial w_{ij}^{(k)}} = y_i^{(k-1)} \frac{\partial Div}{\partial z_j^{(k)}}$ for $j = 0 \dots D_{k-1}$

Backward Pass

- Output layer (N) :

- For $i = 1 \dots D_N$

- $\frac{\partial Div}{\partial y_i^{(N)}} = \frac{\partial Div(Y,d)}{\partial y_i}$
- $\frac{\partial Div}{\partial z_i^{(N)}} = \frac{\partial Div}{\partial y_i^{(N)}} f'_N(z_i^{(N)})$
- $\frac{\partial Div}{\partial w_{ij}^{(N)}} = y_i^{(N-1)} \frac{\partial Div}{\partial z_j^{(N)}} \text{ for } j = 0 \dots D_{N-1}$

Called “**Backpropagation**” because the derivative of the loss is propagated “backwards” through the network

- For layer $k = N - 1$ *downto* 1

Very analogous to the forward pass:

- For $i = 1 \dots D_k$

- $\frac{\partial Div}{\partial y_i^{(k)}} = \sum_j w_{ij}^{(k+1)} \frac{\partial Div}{\partial z_j^{(k+1)}}$
- $\frac{\partial Div}{\partial z_i^{(k)}} = \frac{\partial Div}{\partial y_i^{(k)}} f'_k(z_i^{(k)})$
- $\frac{\partial Div}{\partial w_{ij}^{(k)}} = y_i^{(k-1)} \frac{\partial Div}{\partial z_j^{(k)}} \text{ for } j = 0 \dots D_{k-1}$

Backward weighted combination of next layer

Backward equivalent of activation

Using notation $\dot{y} = \frac{\partial Div(Y,d)}{\partial y}$ etc (overdot represents derivative of *Div* w.r.t variable)

- Output layer (N) :

- For $i = 1 \dots D_N$

- $\dot{y}_i^{(N)} = \frac{\partial Div}{\partial y_i}$

- $\dot{z}_i^{(N)} = \dot{y}_i^{(N)} f'_N(z_i^{(N)})$

- $\frac{\partial Div}{\partial w_{ji}^{(N)}} = y_j^{(N-1)} \dot{z}_i^{(N)}$ for $j = 0 \dots D_{N-1}$

Called "**Backpropagation**" because the derivative of the loss is propagated "backwards" through the network

- For layer $k = N - 1$ downto 1

- For $i = 1 \dots D_k$

- $\dot{y}_i^{(k)} = \sum_j w_{ij}^{(k+1)} \dot{z}_j^{(k+1)}$ ←

Backward weighted combination of next layer

- $\dot{z}_i^{(k)} = \dot{y}_i^{(k)} f'_k(z_i^{(k)})$ ←

Backward equivalent of activation

- $\frac{\partial Div}{\partial w_{ji}^{(k)}} = y_j^{(k-1)} \dot{z}_i^{(k)}$ for $j = 0 \dots D_{k-1}$

For comparison: the forward pass again

- Input: D dimensional vector $\mathbf{x} = [x_j, j = 1 \dots D]$
- Set:
 - $D_0 = D$, is the width of the 0^{th} (input) layer
 - $y_j^{(0)} = x_j, j = 1 \dots D; \quad y_0^{(k=1 \dots N)} = x_0 = 1$
- For layer $k = 1 \dots N$
 - For $j = 1 \dots D_k$
 - $z_j^{(k)} = \sum_{i=0}^{N_k} w_{i,j}^{(k)} y_i^{(k-1)}$
 - $y_j^{(k)} = f_k(z_j^{(k)})$
- Output:
 - $Y = y_j^{(N)}, j = 1 \dots D_N$

Poll 2 (@389)

How does backpropagation relate to training the network (pick one)

- Backpropagation is the process of training the network
- Backpropagation is used to update the model parameters during training
- Backpropagation is used to compute the derivatives of the divergence with respect to model parameters, to be used in gradient descent.

Poll 2

How does backpropagation relate to training the network (pick one)

- Backpropagation is the process of training the network
- Backpropagation is used to update the model parameters during training
- Backpropagation is used to compute the derivatives of the divergence with respect to model parameters, to be used in gradient descent. **(correct)**

Special cases

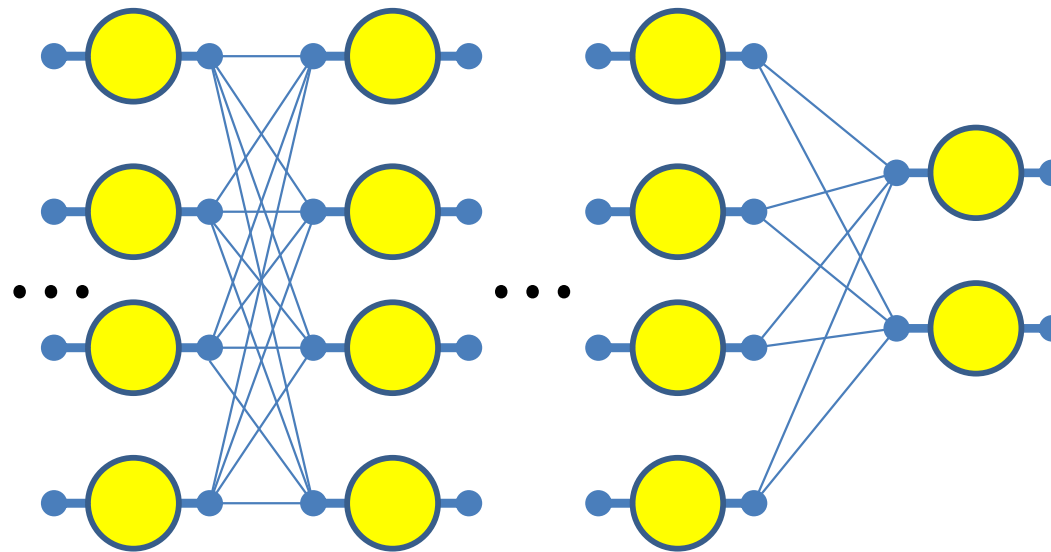

- Have assumed so far that
 1. The computation of the output of one neuron does not directly affect computation of other neurons in the same (or previous) layers
 2. Inputs to neurons only combine through weighted addition
 3. Activations are actually differentiable
 - All of these conditions are frequently not applicable
- Will not discuss all of these in class, but explained in slides
 - Will appear in quiz. Please read the slides

Special Case 1. Vector activations

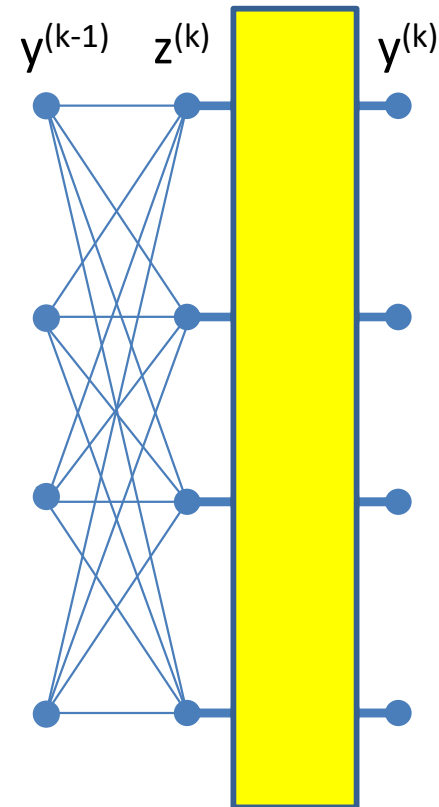
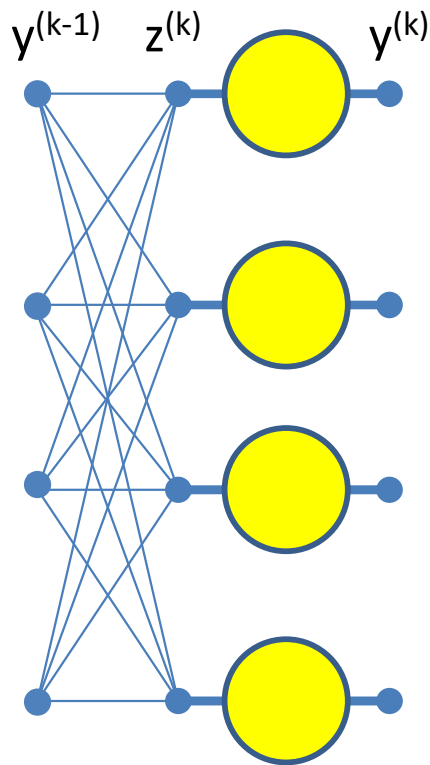

- Vector activations: all outputs are functions of all inputs

Special Case 1. Vector activations

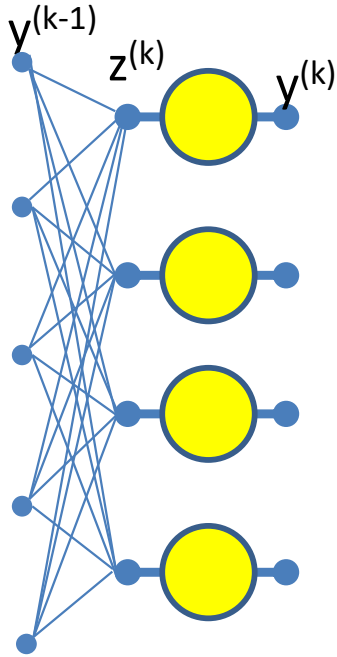

Scalar activation: Modifying a z_i only changes corresponding y_i

$$y_i^{(k)} = f(z_i^{(k)})$$

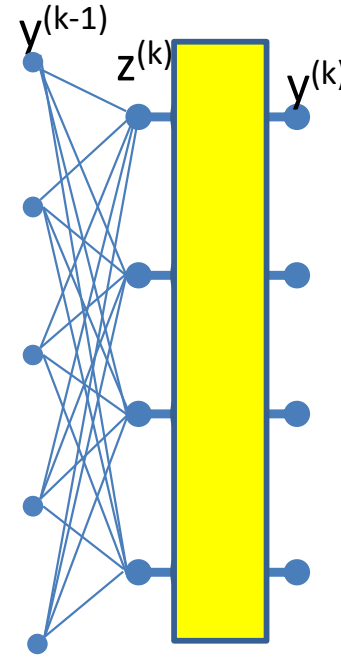

Vector activation: Modifying a z_i potentially changes all, $y_1 \dots y_M$

$$\begin{bmatrix} y_1^{(k)} \\ y_2^{(k)} \\ \vdots \\ y_M^{(k)} \end{bmatrix} = f \left(\begin{bmatrix} z_1^{(k)} \\ z_2^{(k)} \\ \vdots \\ z_D^{(k)} \end{bmatrix} \right)$$

“Influence” diagram

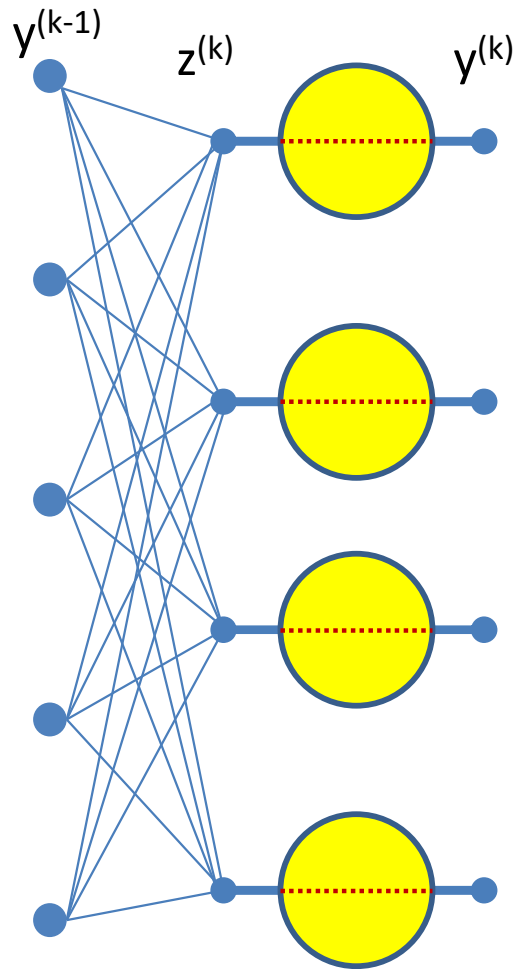

Scalar activation: Each z_i influences *one* y_i

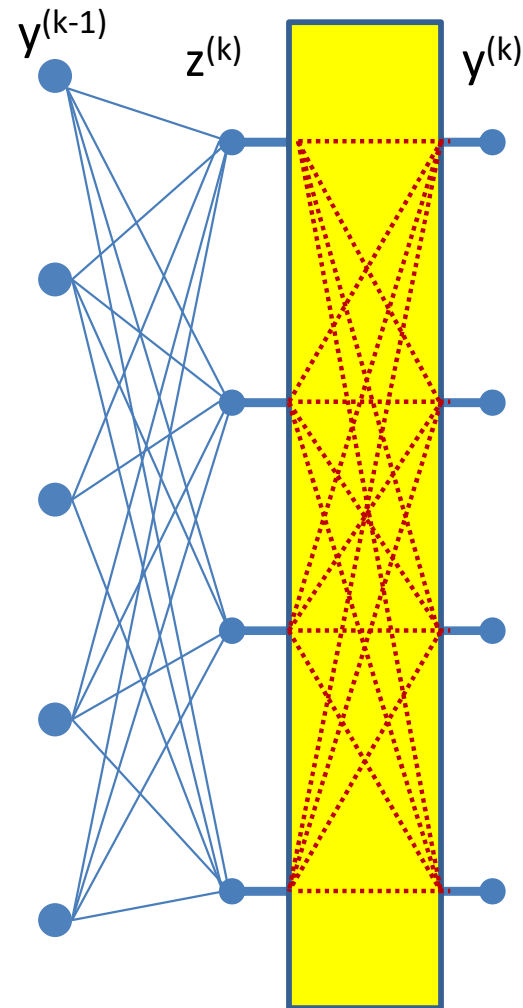

Vector activation: Each z_i influences all, $y_1 \dots y_M$

Scalar Activation: Derivative rule

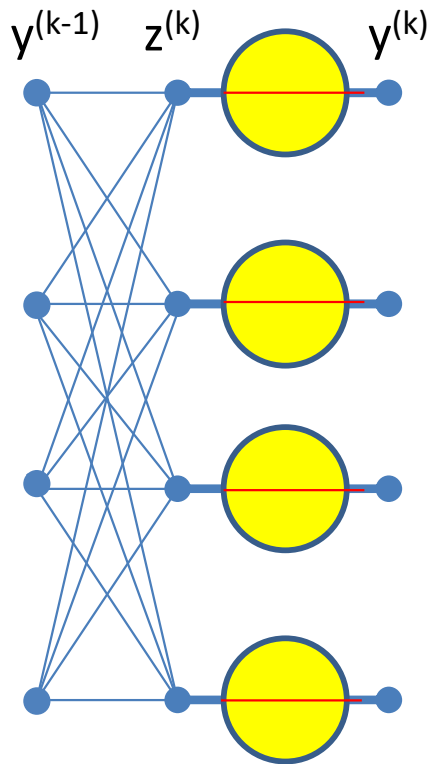

$$\frac{\partial Div}{\partial z_i^{(k)}} = \frac{\partial Div}{\partial y_i^{(k)}} \frac{dy_i^{(k)}}{dz_i^{(k)}}$$

- In the case of *scalar* activation functions, the derivative of the loss w.r.t to the input to the unit is a simple product of derivatives

Derivatives of vector activation

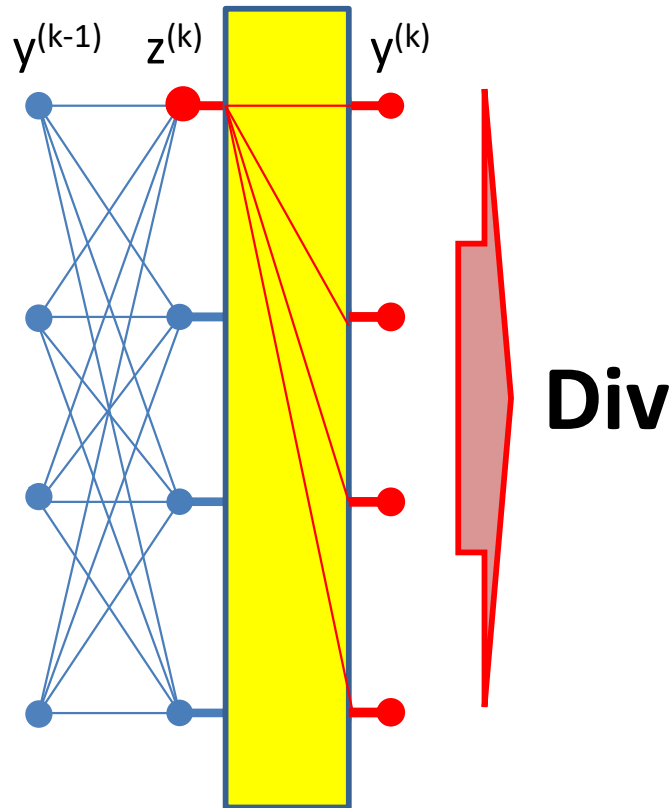

$$\frac{\partial Div}{\partial z_i^{(k)}} = \sum_j \frac{\partial Div}{\partial y_j^{(k)}} \frac{\partial y_j^{(k)}}{\partial z_i^{(k)}}$$

Note: derivatives of scalar activations are just a special case of vector activations:

$$\frac{\partial y_j^{(k)}}{\partial z_i^{(k)}} = 0 \text{ for } i \neq j$$

- For *vector* activations the derivative of the loss w.r.t. to any input is a sum of partial derivatives
 - Regardless of the number of outputs $y_j^{(k)}$

Example Vector Activation: Softmax

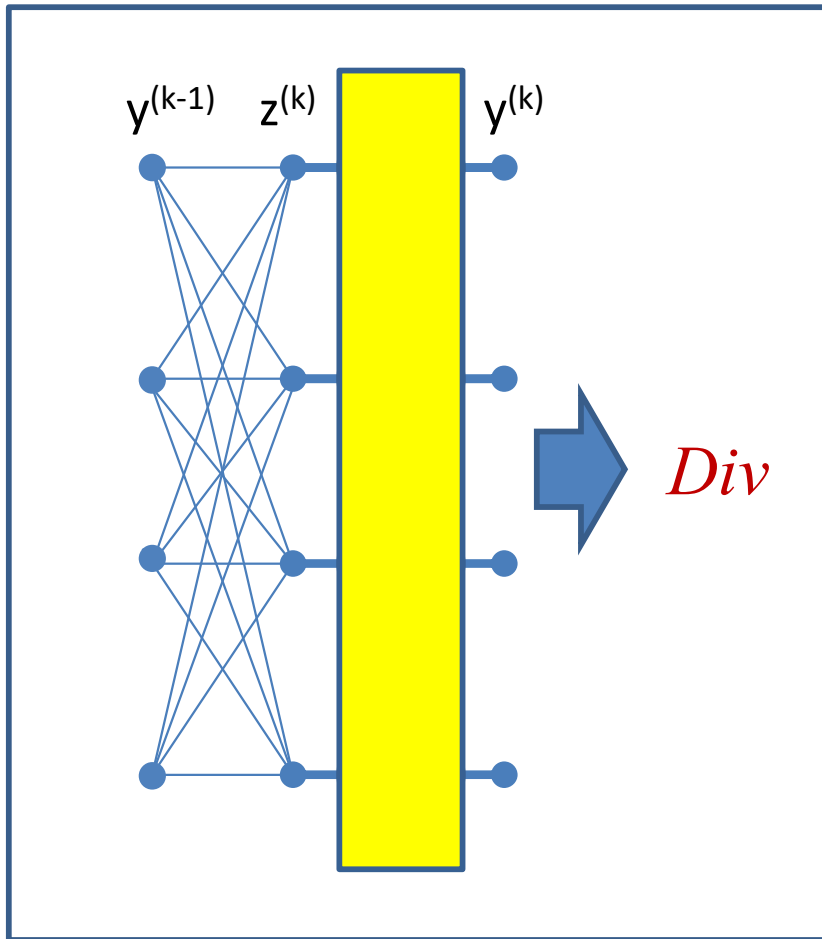

$$y_i^{(k)} = \frac{\exp(z_i^{(k)})}{\sum_j \exp(z_j^{(k)})}$$

Example Vector Activation: Softmax

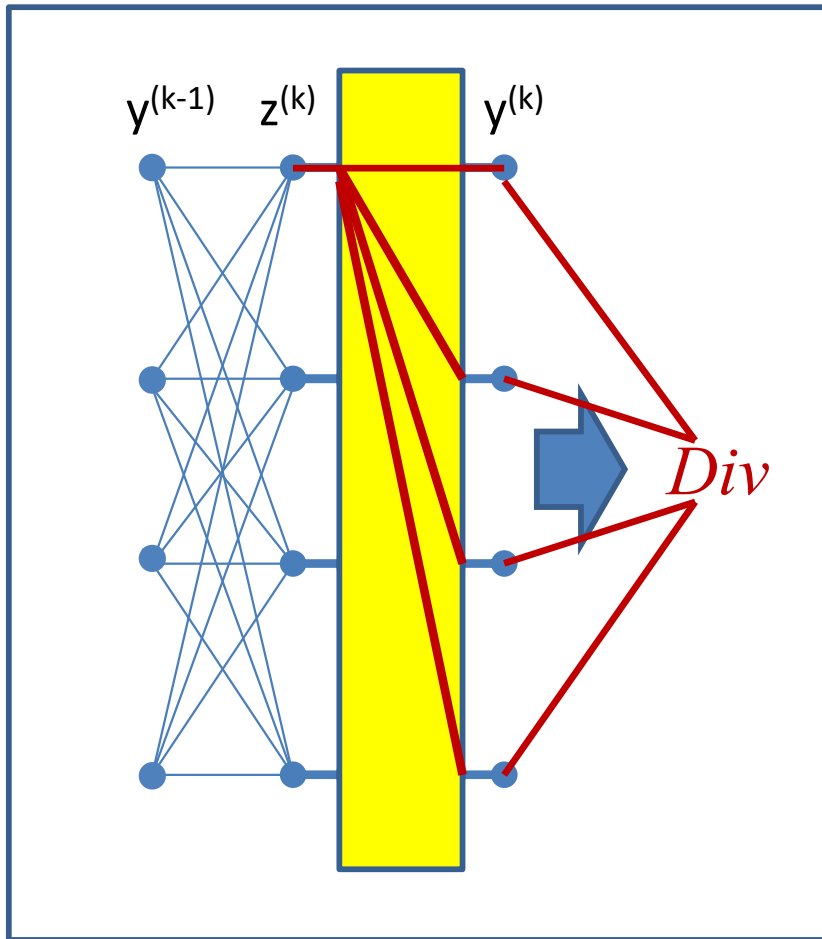

$$y_i^{(k)} = \frac{\exp(z_i^{(k)})}{\sum_j \exp(z_j^{(k)})}$$

$$\frac{\partial Div}{\partial z_i^{(k)}} = \sum_j \frac{\partial Div}{\partial y_j^{(k)}} \frac{\partial y_j^{(k)}}{\partial z_i^{(k)}}$$

Example Vector Activation: Softmax

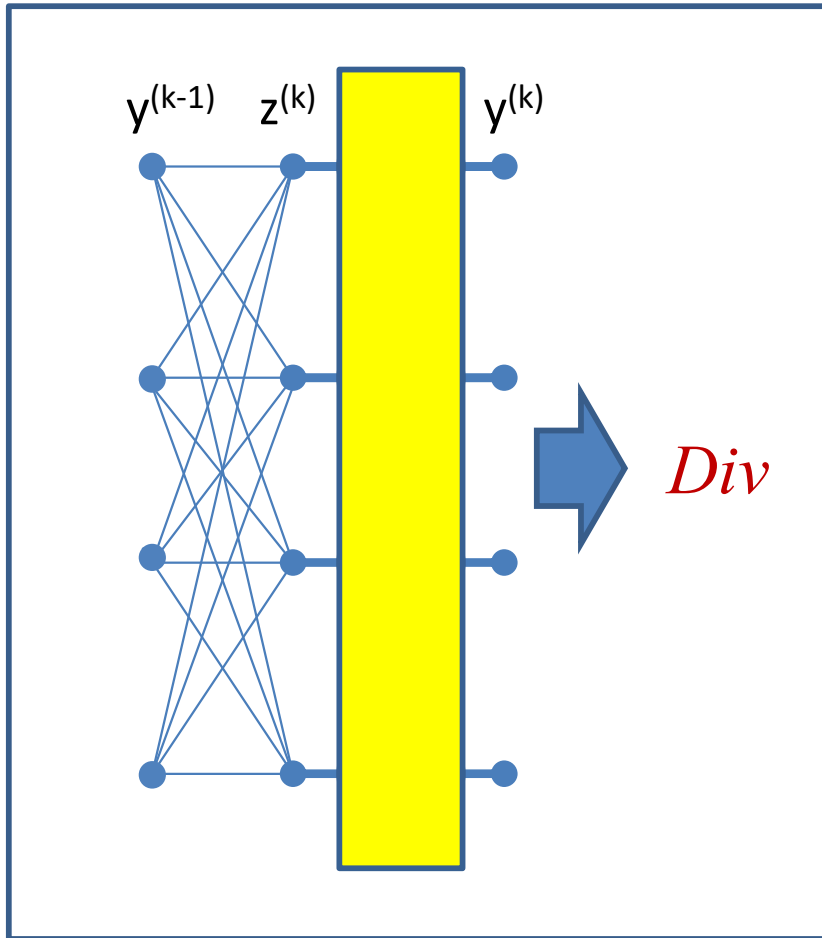

$$y_i^{(k)} = \frac{\exp(z_i^{(k)})}{\sum_j \exp(z_j^{(k)})}$$

$$\frac{\partial Div}{\partial z_i^{(k)}} = \sum_j \frac{\partial Div}{\partial y_j^{(k)}} \frac{\partial y_j^{(k)}}{\partial z_i^{(k)}}$$

$$\frac{\partial y_j^{(k)}}{\partial z_i^{(k)}} = \begin{cases} y_i^{(k)} (1 - y_i^{(k)}) & \text{if } i = j \\ -y_i^{(k)} y_j^{(k)} & \text{if } i \neq j \end{cases}$$

Example Vector Activation: Softmax

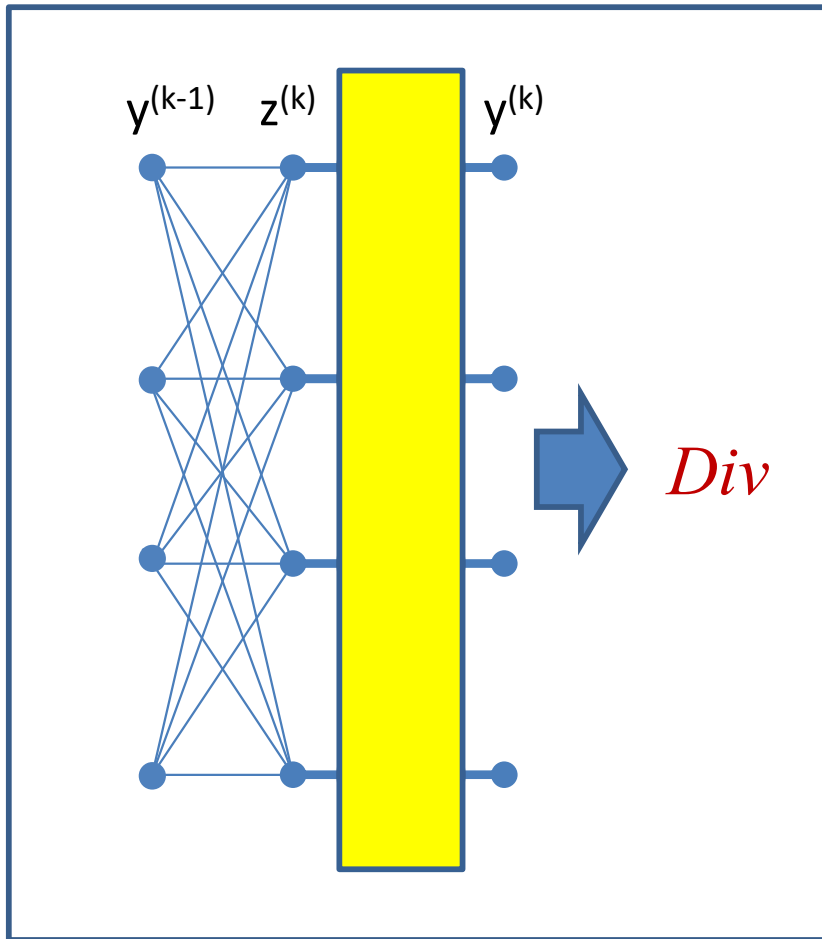

$$y_i^{(k)} = \frac{\exp(z_i^{(k)})}{\sum_j \exp(z_j^{(k)})}$$

$$\frac{\partial Div}{\partial z_i^{(k)}} = \sum_j \frac{\partial Div}{\partial y_j^{(k)}} \frac{\partial y_j^{(k)}}{\partial z_i^{(k)}}$$

$$\frac{\partial y_j^{(k)}}{\partial z_i^{(k)}} = \begin{cases} y_i^{(k)} (1 - y_i^{(k)}) & \text{if } i = j \\ -y_i^{(k)} y_j^{(k)} & \text{if } i \neq j \end{cases}$$

$$\frac{\partial Div}{\partial z_i^{(k)}} = \sum_j \frac{\partial Div}{\partial y_j^{(k)}} y_j^{(k)} (\delta_{ij} - y_i^{(k)})$$

- For future reference
- δ_{ij} is the Kronecker delta: $\delta_{ij} = 1$ if $i = j$, 0 if $i \neq j$

Backward Pass for *softmax output layer*

- Output layer (N) :
 - For $i = 1 \dots D_N$
 - $\frac{\partial Div}{\partial y_i^{(N)}} = \frac{\partial Div(Y,d)}{\partial y_i}$
 - $\frac{\partial Div}{\partial z_i^{(N)}} = \sum_j \frac{\partial Div(Y,d)}{\partial y_j^{(N)}} y_i^{(N)} (\delta_{ij} - y_j^{(N)})$
 - $\frac{\partial Di}{\partial w_{ij}^{(N)}} = y_i^{(N-1)} \frac{\partial Div}{\partial z_j^{(N)}}$ for $j = 0 \dots D_{N-1}$
- For layer $k = N - 1$ *downto* 1
 - For $i = 1 \dots D_k$
 - $\frac{\partial Div}{\partial y_i^{(k)}} = \sum_j w_{ij}^{(k+1)} \frac{\partial Div}{\partial z_j^{(k+1)}}$
 - $\frac{\partial Div}{\partial z_i^{(k)}} = \frac{\partial Div}{\partial y_i^{(k)}} f'_k(z_i^{(k)})$
 - $\frac{\partial Div}{\partial w_{ij}^{(k)}} = y_i^{(k-1)} \frac{\partial Div}{\partial z_j^{(k)}}$ for $j = 0 \dots D_{k-1}$

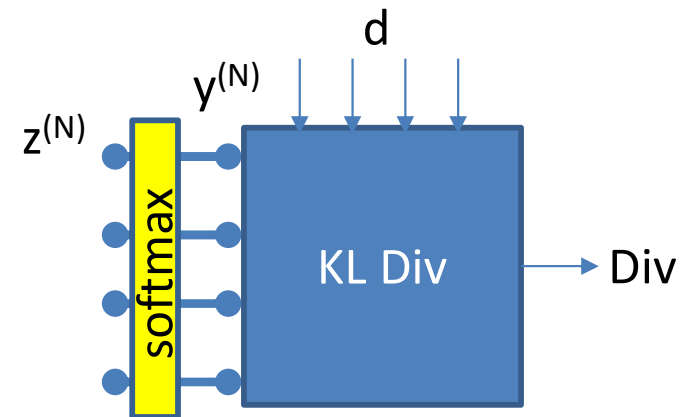

Special cases

- Examples of vector activations and other special cases on slides
 - Please look up
 - Will appear in quiz!

Vector Activations

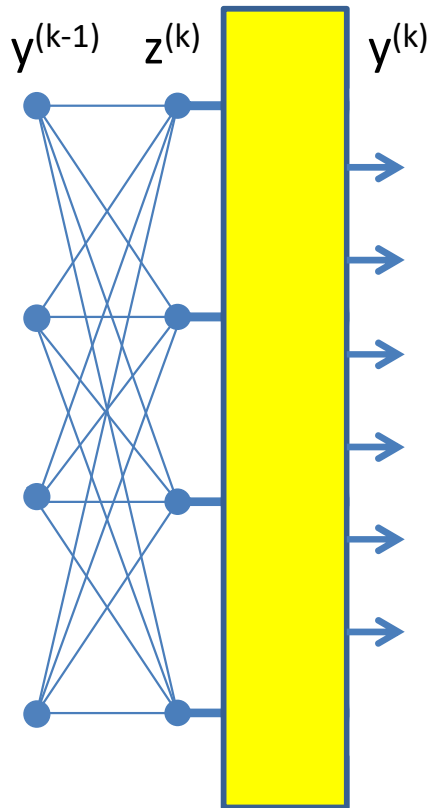

$$\begin{bmatrix} y_1^{(k)} \\ y_2^{(k)} \\ \vdots \\ y_M^{(k)} \end{bmatrix} = f \left(\begin{bmatrix} z_1^{(k)} \\ z_2^{(k)} \\ \vdots \\ z_D^{(k)} \end{bmatrix} \right)$$

- In reality the vector combinations can be anything
 - E.g. linear combinations, polynomials, logistic (softmax), etc.

Special Case 2: Multiplicative networks

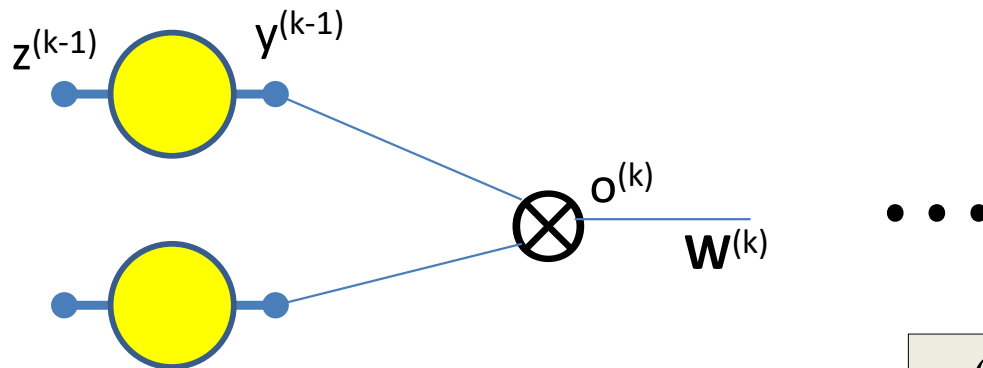

Forward:
$$o_i^{(k)} = y_j^{(k-1)} y_l^{(k-1)}$$

- Some types of networks have *multiplicative* combination
 - In contrast to the *additive* combination we have seen so far
- Seen in networks such as LSTMs, GRUs, attention models, etc.

Backpropagation: Multiplicative Networks

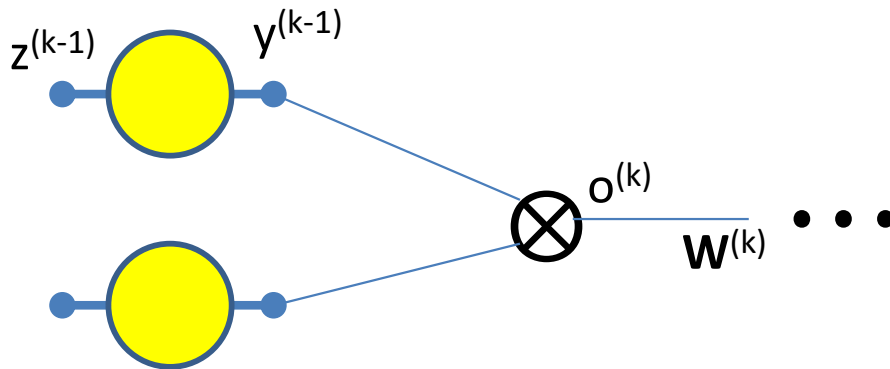

Forward:

$$o_i^{(k)} = y_j^{(k-1)} y_l^{(k-1)}$$

Backward:

$$\frac{\partial Div}{\partial o_i^{(k)}} = \sum_j w_{ij}^{(k+1)} \frac{\partial Div}{\partial z_j^{(k+1)}}$$

$$\frac{\partial Div}{\partial y_j^{(k-1)}} = \frac{\partial o_i^{(k)}}{\partial y_j^{(k-1)}} \frac{\partial Div}{\partial o_i^{(k)}} = y_l^{(k-1)} \frac{\partial Div}{\partial o_i^{(k)}}$$

$$\frac{\partial Div}{\partial y_l^{(k-1)}} = y_j^{(k-1)} \frac{\partial Div}{\partial o_i^{(k)}}$$

- Some types of networks have *multiplicative* combination

Multiplicative combination as a case of vector activations

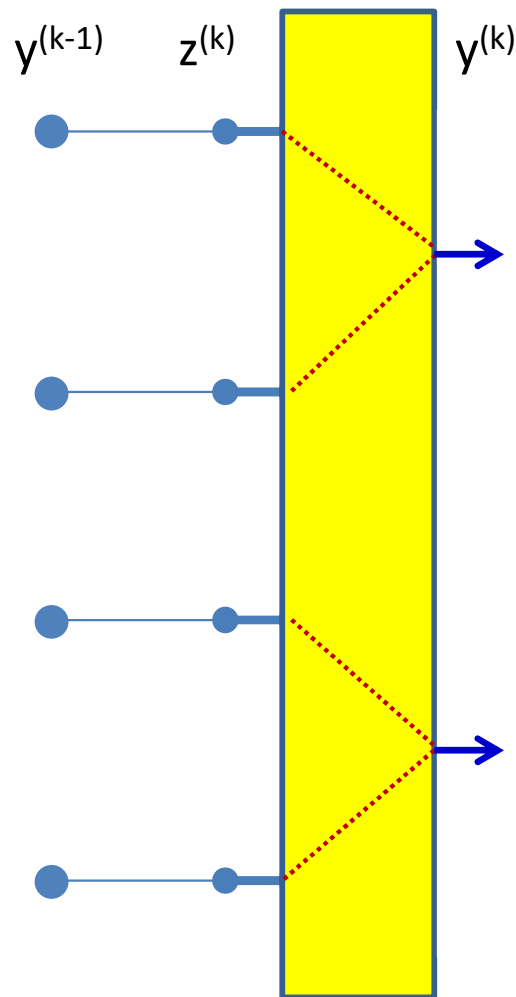

$$z_i^{(k)} = y_i^{(k-1)}$$

$$y_i^{(k)} = z_{2i-1}^{(k)} z_{2i}^{(k)}$$

- A layer of multiplicative combination is a special case of vector activation

Multiplicative combination: Can be viewed as a case of vector activations

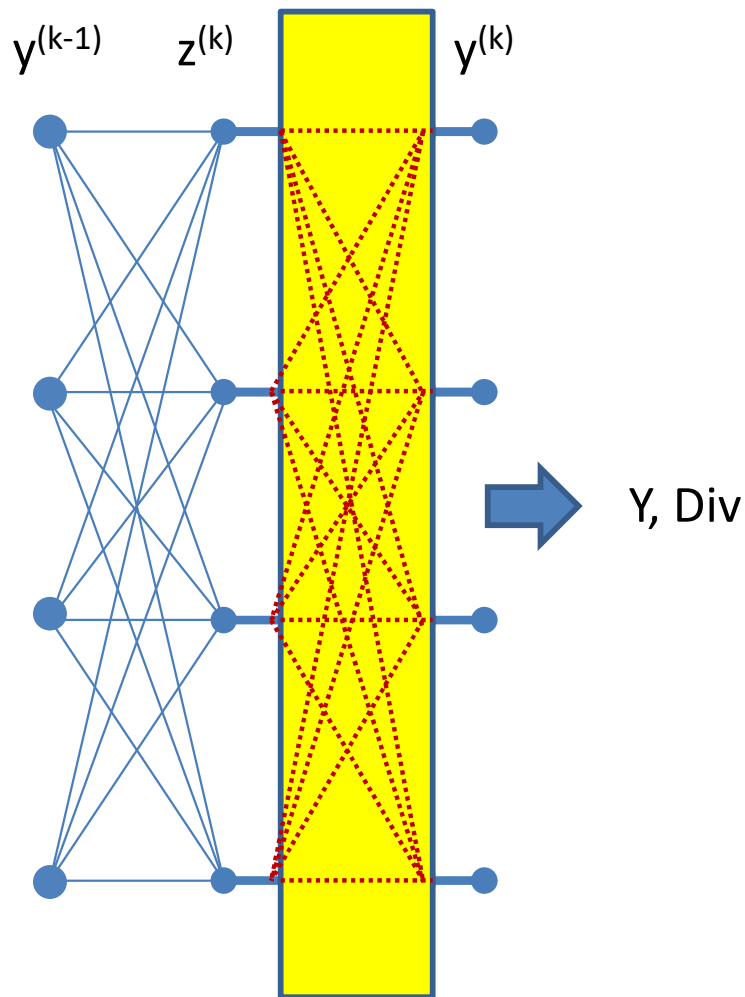

$$z_i^{(k)} = \sum_j w_{ji}^{(k)} y_j^{(k-1)}$$

$$y_i^{(k)} = \prod_l (z_l^{(k)})^{\alpha_{li}^{(k)}}$$

$$\frac{\partial y_i^{(k)}}{\partial z_j^{(k)}} = \alpha_{ji}^{(k)} (z_j^{(k)})^{\alpha_{ji}^{(k)} - 1} \prod_{l \neq j} (z_l^{(k)})^{\alpha_{li}^{(k)}}$$

$$\frac{\partial Div}{\partial z_j^{(k)}} = \sum_i \frac{\partial Div}{\partial y_i^{(k)}} \frac{\partial y_i^{(k)}}{\partial z_j^{(k)}}$$

- A layer of multiplicative combination is a special case of vector activation

Gradients: Backward Computation

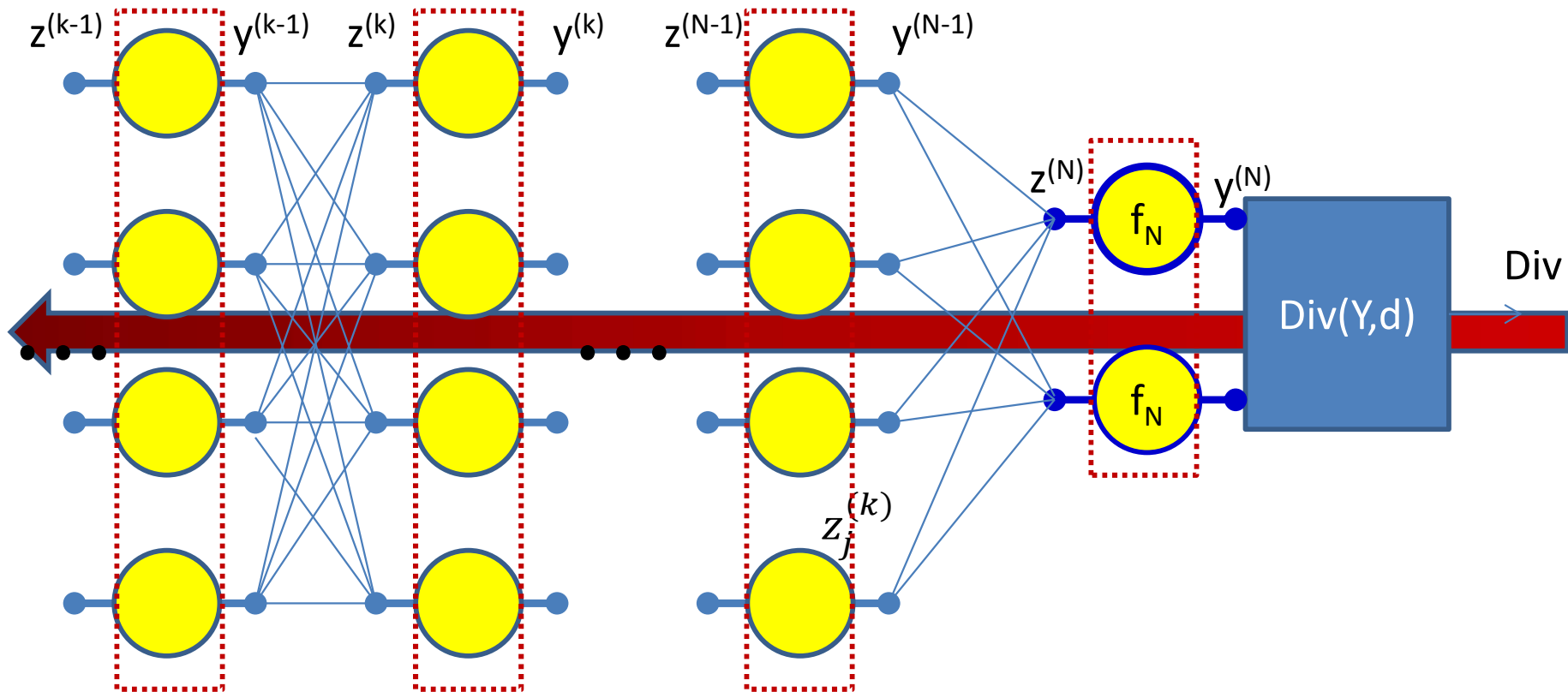

For $k = N \dots 1$

For $i = 1 : \text{layer width}$

If layer has vector activation

$$\frac{\partial \text{Div}}{\partial z_i^{(k)}} = \sum_j \frac{\partial \text{Div}}{\partial y_j^{(k)}} \frac{\partial y_j^{(k)}}{\partial z_i^{(k)}}$$

$$\frac{\partial \text{Div}}{\partial y_i^{(k-1)}} = \sum_j w_{ij}^{(k)} \frac{\partial \text{Div}}{\partial z_j^{(k)}}$$

Else if activation is scalar

$$\frac{\partial \text{Div}}{\partial z_i^{(k)}} = \frac{\partial \text{Div}}{\partial y_i^{(k)}} \frac{\partial y_i^{(k)}}{\partial z_i^{(k)}}$$

$$\frac{\partial \text{Div}}{\partial w_{ij}^{(k)}} = y_i^{(k-1)} \frac{\partial \text{Div}}{\partial z_j^{(k)}}$$

Special Case : Non-differentiable activations

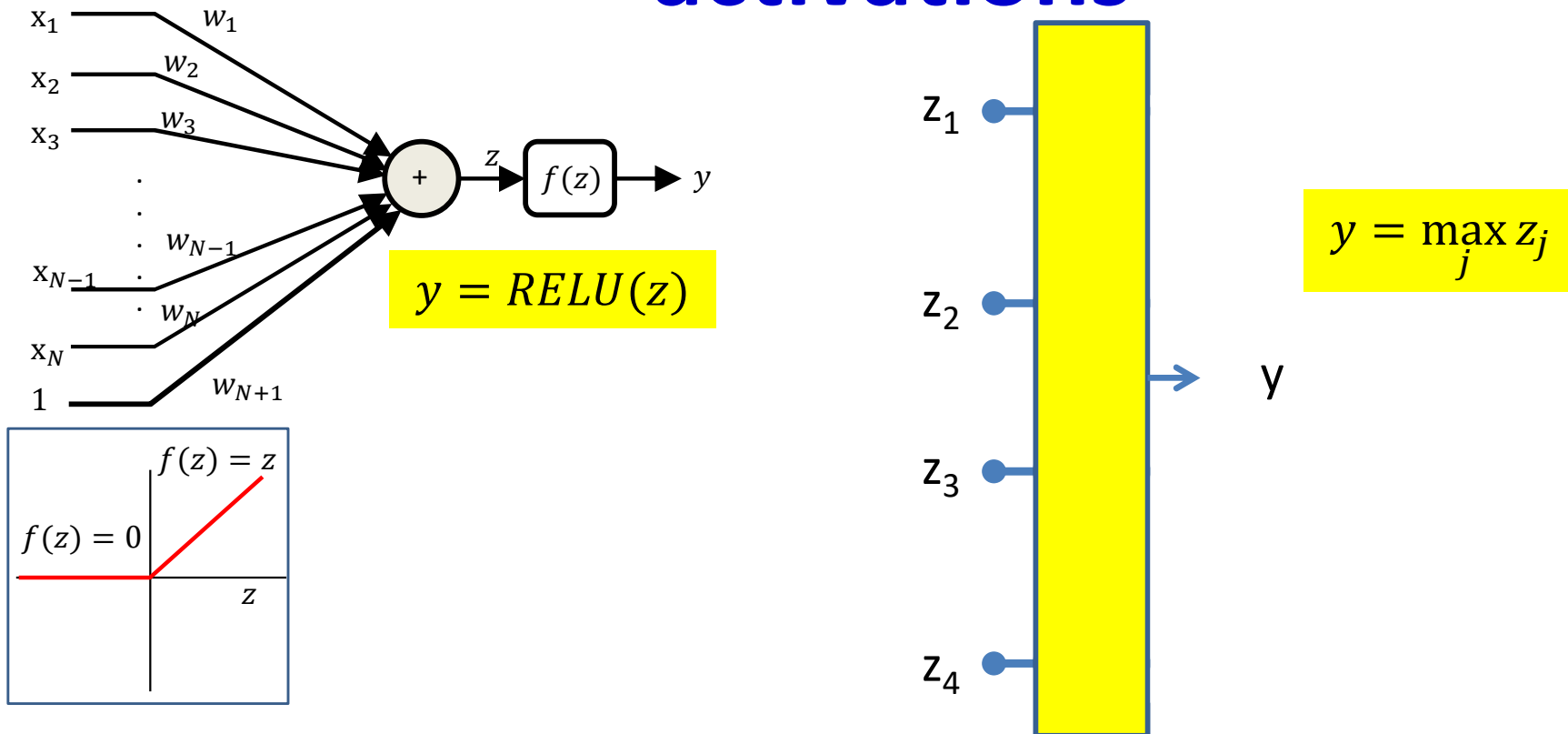

- Activation functions are sometimes not actually differentiable
 - E.g. The RELU (Rectified Linear Unit)
 - And its variants: leaky RELU, randomized leaky RELU
 - E.g. The “max” function
- Must use “subgradients” where available
 - Or “secants”

The subgradient

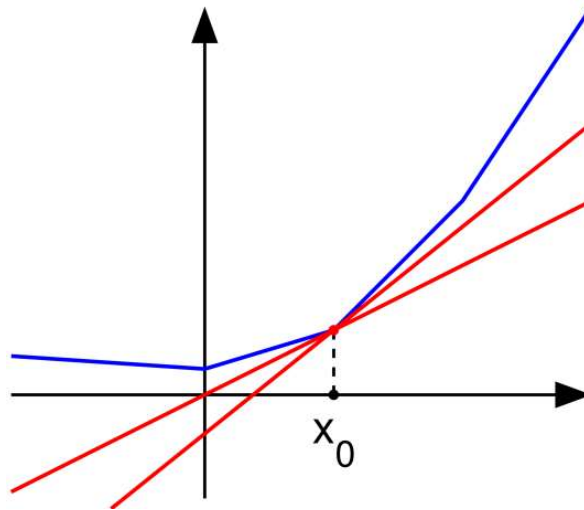

- A subgradient of a function $f(x)$ at a point x_0 is any vector v such that
$$(f(x) - f(x_0)) \geq v^T (x - x_0)$$
 - Any direction such that moving in that direction increases the function
- Guaranteed to exist only for convex functions
 - “bowl” shaped functions
 - For non-convex functions, the equivalent concept is a “quasi-secant”
- The subgradient is a direction in which the function is guaranteed to increase
- If the function is differentiable at x_0 , the subgradient is the gradient
 - The gradient is not always the subgradient though

Non-differentiability: RELU

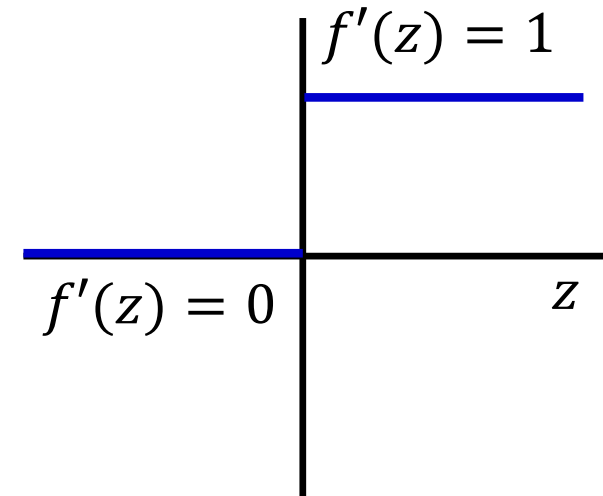
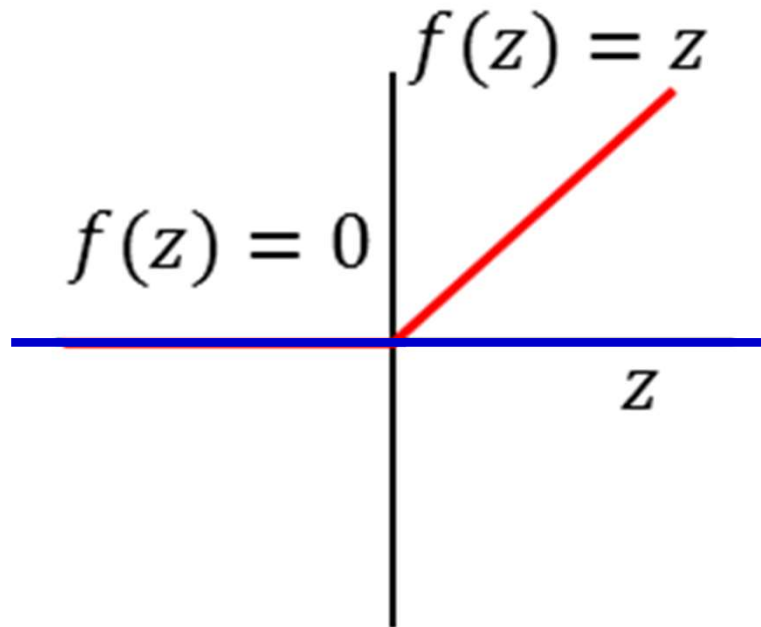

$$f'(z) = \begin{cases} 0, & z < 0 \\ 1, & z \geq 0 \end{cases}$$

$$\Delta f(z) = \alpha \Delta z$$

- At 0 a *negative* perturbation $\Delta z < 0$ results in no change of $f(z)$
 - $\alpha = 0$
- A *positive* perturbation $\Delta z > 0$ results in $\Delta f(z) = \Delta z$
 - $\alpha = 1$
- Peering very closely, we can imagine that the curve is rotating continuously from slope = 0 to slope = 1 at $z = 0$
 - So any slope between 0 and 1 is valid

Subgradients and the RELU

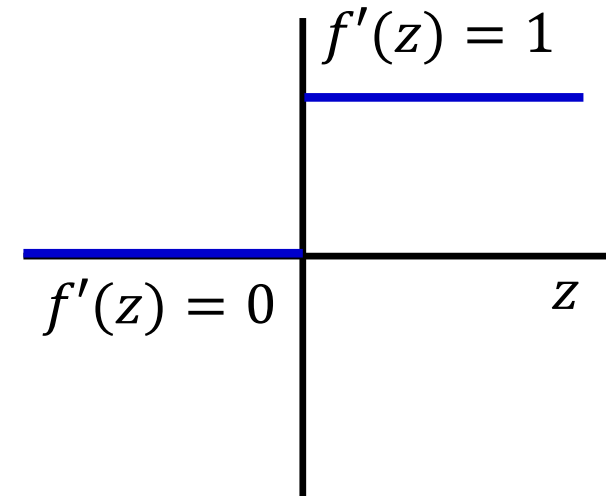
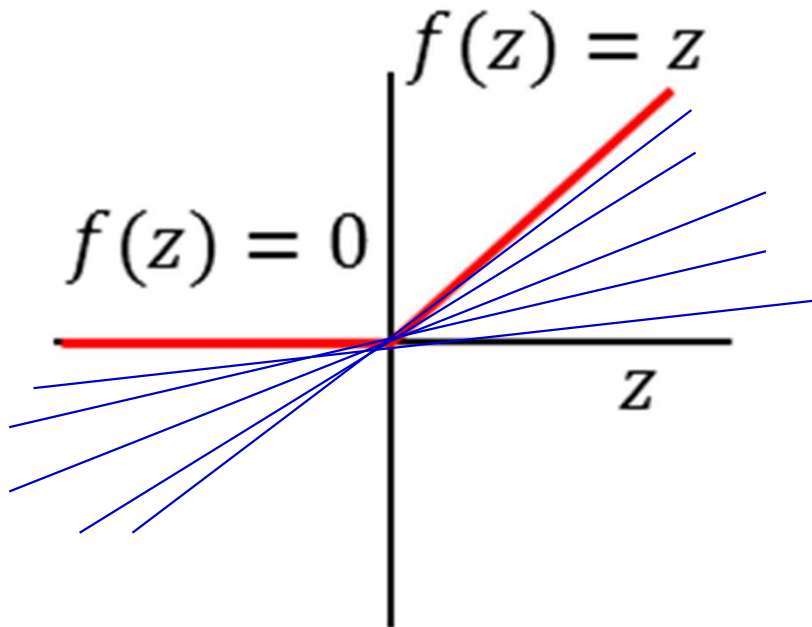

$$f'(z) = \begin{cases} 0, & z < 0 \\ 1, & z \geq 0 \end{cases}$$

- The *subderivative* of a RELU is the slope of any line that lies entirely under it
 - The subgradient is a generalization of the subderivative
 - At the differentiable points on the curve, this is the same as the gradient
- Can use any subgradient at 0
 - Typically, will use the equation given

Subgradients and the Max

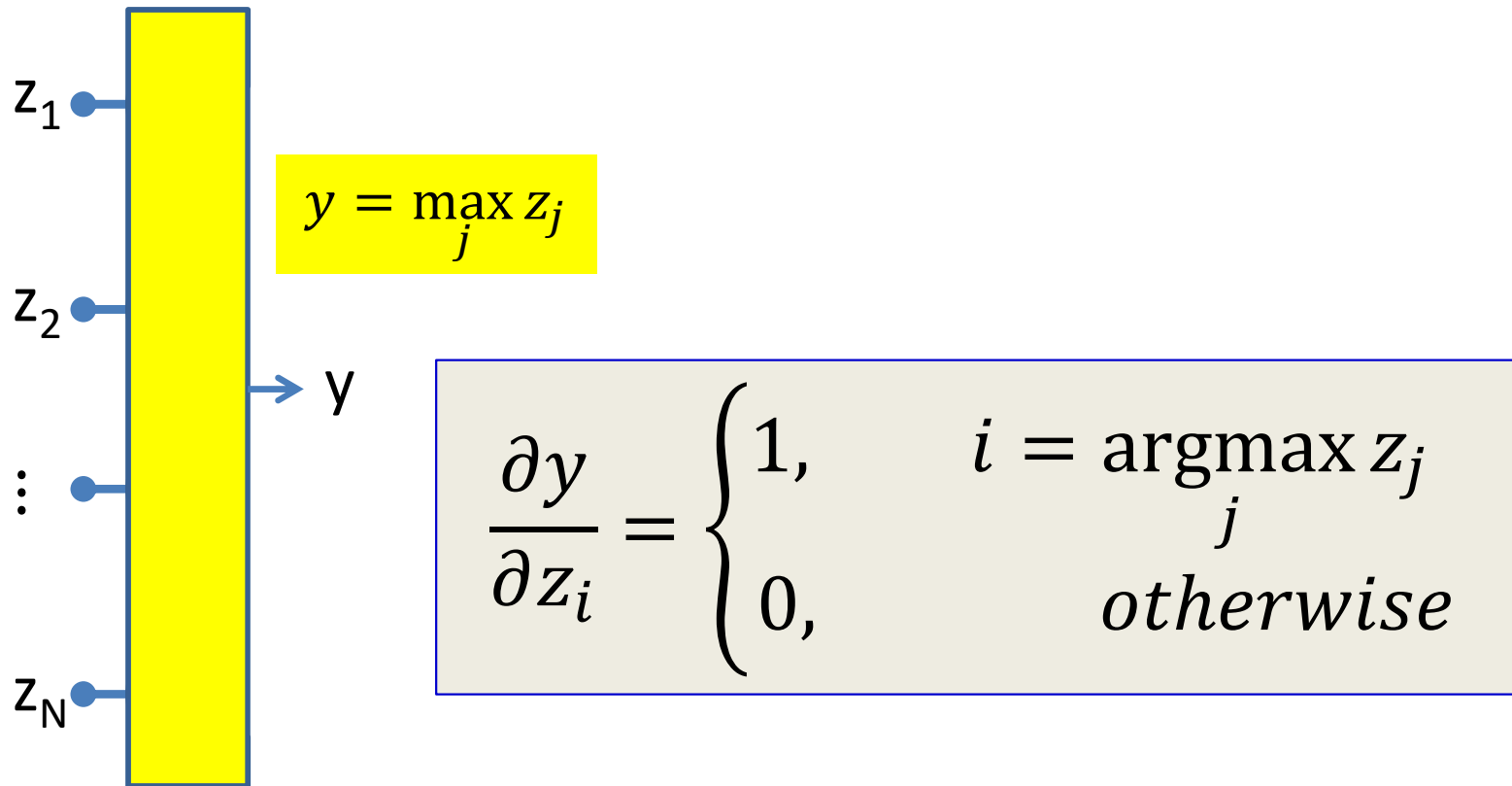

- Vector equivalent of subgradient
 - 1 w.r.t. the largest incoming input
 - Incremental changes in this input will change the output
 - 0 for the rest
 - Incremental changes to these inputs will not change the output

Poll 3 (@390)

We have $y = \max(z_1, z_2, z_3)$, computed at $z_1 = 1, z_2 = 2, z_3 = 3$. Select all that are true

- $dy/dz_1 = 1$
- $dy/dz_1 = 0$
- $dy/dz_2 = 1$
- $dy/dz_2 = 0$
- $dy/dz_3 = 1$
- $dy/dz_3 = 0$

Poll 3

We have $y = \max(z_1, z_2, z_3)$, computed at $z_1 = 1, z_2 = 2, z_3 = 3$. Select all that are true

- $dy/dz_1 = 1$
- $dy/dz_1 = 0$ **(correct)**
- $dy/dz_2 = 1$
- $dy/dz_2 = 0$ **(correct)**
- $dy/dz_3 = 1$ **(correct)**
- $dy/dz_3 = 0$

Subgradients and the Max

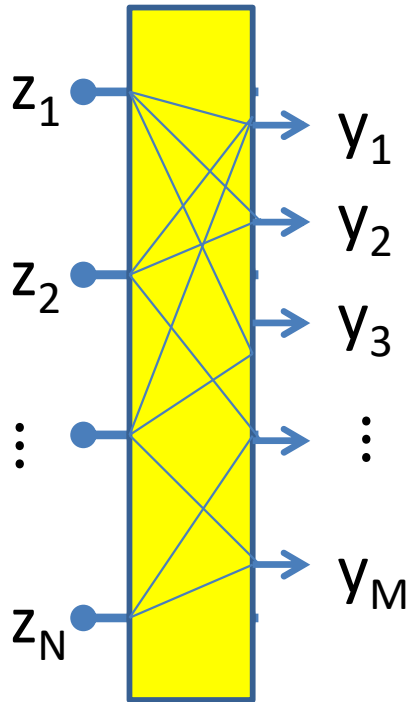

$$y_i = \max_{l \in \mathcal{S}_j} z_l$$

$$\frac{\partial y_j}{\partial z_i} = \begin{cases} 1, & i = \operatorname{argmax}_{l \in \mathcal{S}_j} z_l \\ 0, & \text{otherwise} \end{cases}$$

- Multiple outputs, each selecting the max of a different subset of inputs
 - Will be seen in convolutional networks
- Gradient for any output:
 - 1 for the specific component that is maximum in corresponding input subset
 - 0 otherwise

Backward Pass: Recap

- Output layer (N) :

- For $i = 1 \dots D_N$

- $\frac{\partial Div}{\partial y_i^{(N)}} = \frac{\partial Div(Y,d)}{\partial y_i}$

- $\frac{\partial Div}{\partial z_i^{(N)}} = \frac{\partial Div}{\partial y_i^{(N)}} \frac{\partial y_i^{(N)}}{\partial z_i^{(N)}} \leftarrow OR \sum_j \frac{\partial Div}{\partial y_j^{(N)}} \frac{\partial y_j^{(N)}}{\partial z_i^{(N)}} \text{ (vector activation)}$

- $\frac{\partial Div}{\partial w_{ji}^{(N)}} = y_j^{(N-1)} \frac{\partial Div}{\partial z_i^{(N)}} \text{ for } j = 0 \dots D_k$

- For layer $k = N - 1$ downto 1

- For $i = 1 \dots D_k$

- $\frac{\partial Div}{\partial y_i^{(k)}} = \sum_j w_{ij}^{(k+1)} \frac{\partial Div}{\partial z_j^{(k+1)}}$

- $\frac{\partial Div}{\partial z_i^{(k)}} = \frac{\partial Div}{\partial y_i^{(k)}} \frac{\partial y_i^{(k)}}{\partial z_i^{(k)}} \leftarrow OR \sum_j \frac{\partial Div}{\partial y_j^{(k)}} \frac{\partial y_j^{(k)}}{\partial z_i^{(k)}} \text{ (vector activation)}$

- $\frac{\partial Div}{\partial w_{ji}^{(k)}} = y_j^{(k-1)} \frac{\partial Div}{\partial z_i^{(k)}} \text{ for } j = 0 \dots D_k$

These may be subgradients

Overall Approach

- For each data instance
 - **Forward pass:** Pass instance forward through the net. Store all intermediate outputs of all computation.
 - **Backward pass:** Sweep backward through the net, iteratively compute all derivatives w.r.t weights
- Actual loss is the sum of the divergence over all training instances

$$\mathbf{Loss} = \frac{1}{|\{X\}|} \sum_X \text{Div}(Y(X), d(X))$$

- Actual gradient is the sum or average of the derivatives computed for each training instance

$$\nabla_W \mathbf{Loss} = \frac{1}{|\{X\}|} \sum_X \nabla_W \text{Div}(Y(X), d(X)) \quad W \leftarrow W - \eta \nabla_W \mathbf{Loss}^T$$

Training by BackProp

- Initialize weights $\mathbf{W}^{(k)}$ for all layers $k = 1 \dots K$
- Do: (*Gradient descent iterations*)
 - Initialize $Loss = 0$; For all i, j, k , initialize $\frac{dLoss}{dw_{i,j}^{(k)}} = 0$
 - For all $t = 1:T$ (*Iterate over training instances*)
 - **Forward pass:** Compute
 - Output \mathbf{Y}_t
 - $Loss += Div(\mathbf{Y}_t, \mathbf{d}_t)$
 - **Backward pass:** For all i, j, k :
 - Compute $\frac{dDiv(\mathbf{Y}_t, \mathbf{d}_t)}{dw_{i,j}^{(k)}}$
 - $\frac{dLoss}{dw_{i,j}^{(k)}} += \frac{dDiv(\mathbf{Y}_t, \mathbf{d}_t)}{dw_{i,j}^{(k)}}$
 - For all i, j, k , update:
$$w_{i,j}^{(k)} = w_{i,j}^{(k)} - \frac{\eta}{T} \frac{dLoss}{dw_{i,j}^{(k)}}$$
- Until $Loss$ has converged

Vector formulation

- For layered networks it is generally simpler to think of the process in terms of vector operations
 - Simpler arithmetic
 - Fast matrix libraries make operations *much* faster
- We can restate the entire process in vector terms
 - This is what is *actually* used in any real system

Vector formulation

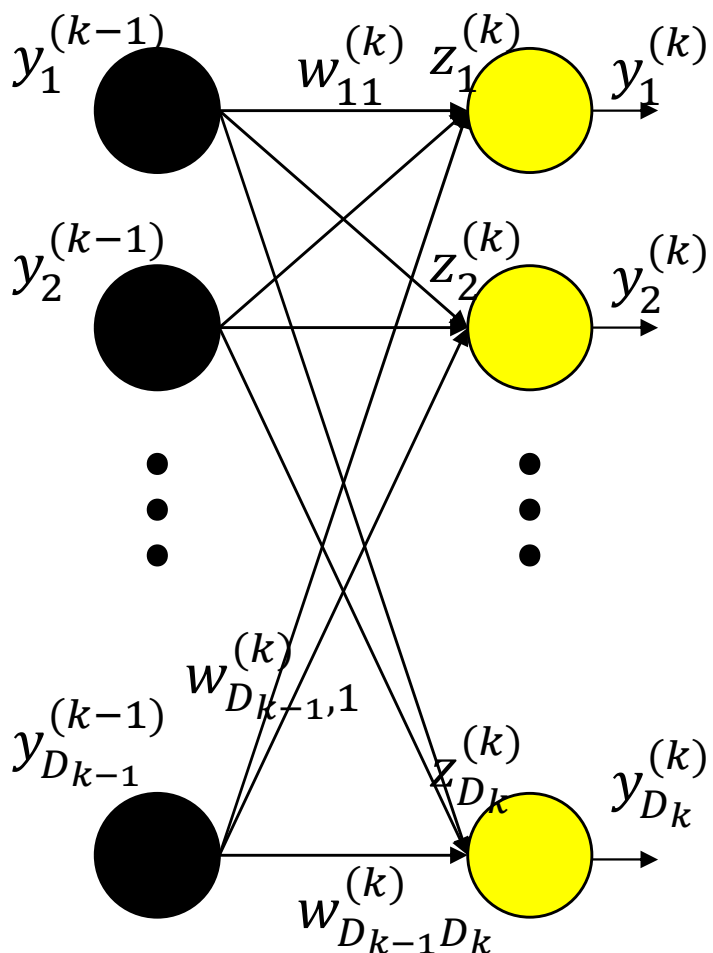

$$\mathbf{z}_k = \begin{bmatrix} z_1^{(k)} \\ z_2^{(k)} \\ \vdots \\ z_{D_k}^{(k)} \end{bmatrix}$$

$$\mathbf{y}_k = \begin{bmatrix} y_1^{(k)} \\ y_2^{(k)} \\ \vdots \\ y_{D_k}^{(k)} \end{bmatrix}$$

$$\mathbf{W}_k = \begin{bmatrix} w_{11}^{(k)} & w_{21}^{(k)} & \vdots & w_{D_{k-1}1}^{(k)} \\ w_{12}^{(k)} & w_{22}^{(k)} & \vdots & w_{D_{k-1}2}^{(k)} \\ \dots & \dots & \ddots & \vdots \\ w_{1D_k}^{(k)} & w_{2D_k}^{(k)} & \dots & w_{D_{k-1}D_k}^{(k)} \end{bmatrix}$$

$$\mathbf{b}_k = \begin{bmatrix} b_1^{(k)} \\ b_2^{(k)} \\ \vdots \\ b_{D_k}^{(k)} \end{bmatrix}$$

- Arrange the *inputs* to neurons of the k th layer as a vector \mathbf{z}_k
- Arrange the *outputs* of neurons in the k th layer as a vector \mathbf{y}_k
- Arrange the weights to any layer as a matrix \mathbf{W}_k
 - Similarly with biases

Vector formulation

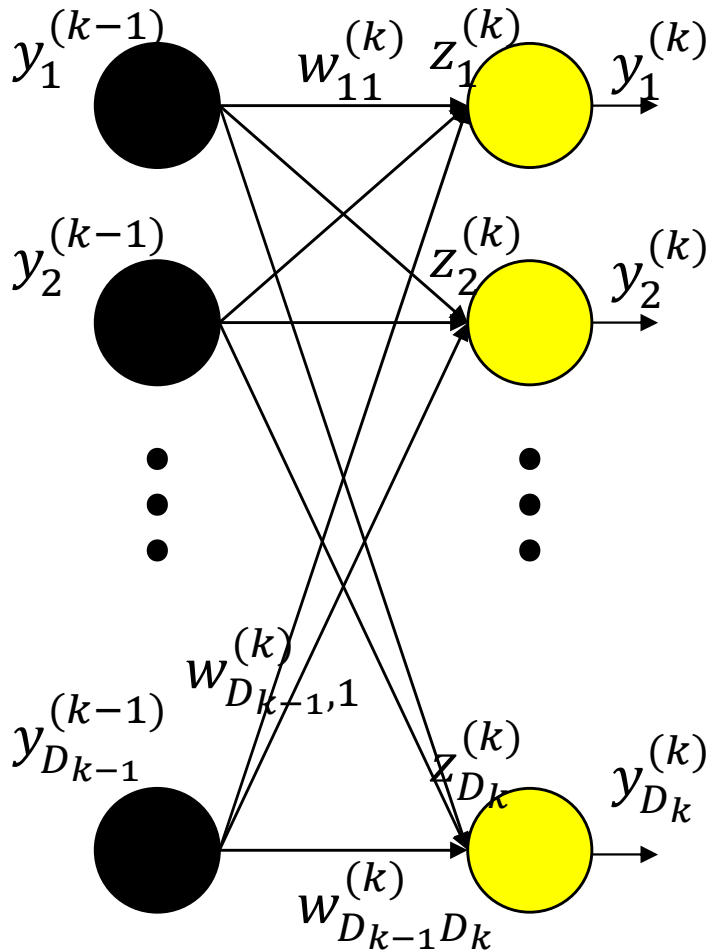

$$\mathbf{z}_k = \begin{bmatrix} z_1^{(k)} \\ z_2^{(k)} \\ \vdots \\ z_{D_k}^{(k)} \end{bmatrix}$$

$$\mathbf{y}_k = \begin{bmatrix} y_1^{(k)} \\ y_2^{(k)} \\ \vdots \\ y_{D_k}^{(k)} \end{bmatrix}$$

$$\mathbf{W}_k = \begin{bmatrix} w_{11}^{(k)} & w_{21}^{(k)} & \cdots & w_{D_{k-1}1}^{(k)} \\ w_{12}^{(k)} & w_{22}^{(k)} & \cdots & w_{D_{k-1}2}^{(k)} \\ \cdots & \cdots & \ddots & \vdots \\ w_{1D_k}^{(k)} & w_{2D_k}^{(k)} & \cdots & w_{D_{k-1}D_k}^{(k)} \end{bmatrix}$$

$$\mathbf{b}_k = \begin{bmatrix} b_1^{(k)} \\ b_2^{(k)} \\ \vdots \\ b_{D_k}^{(k)} \end{bmatrix}$$

- The computation of a single layer is easily expressed in matrix notation as (setting $\mathbf{y}_0 = \mathbf{x}$):

$$\mathbf{z}_k = \mathbf{W}_k \mathbf{y}_{k-1} + \mathbf{b}_k$$

$$\mathbf{y}_k = f_k(\mathbf{z}_k)$$

The forward pass: Evaluating the network

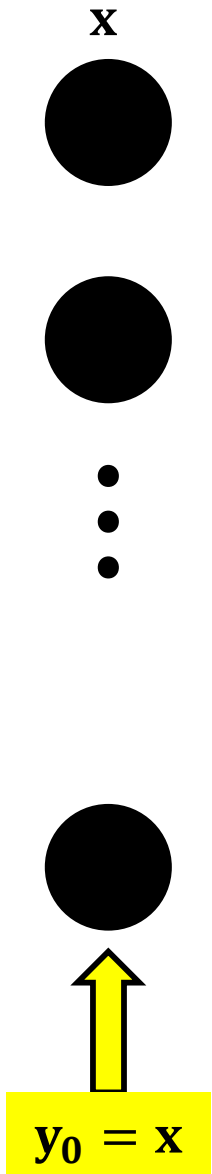

The forward pass

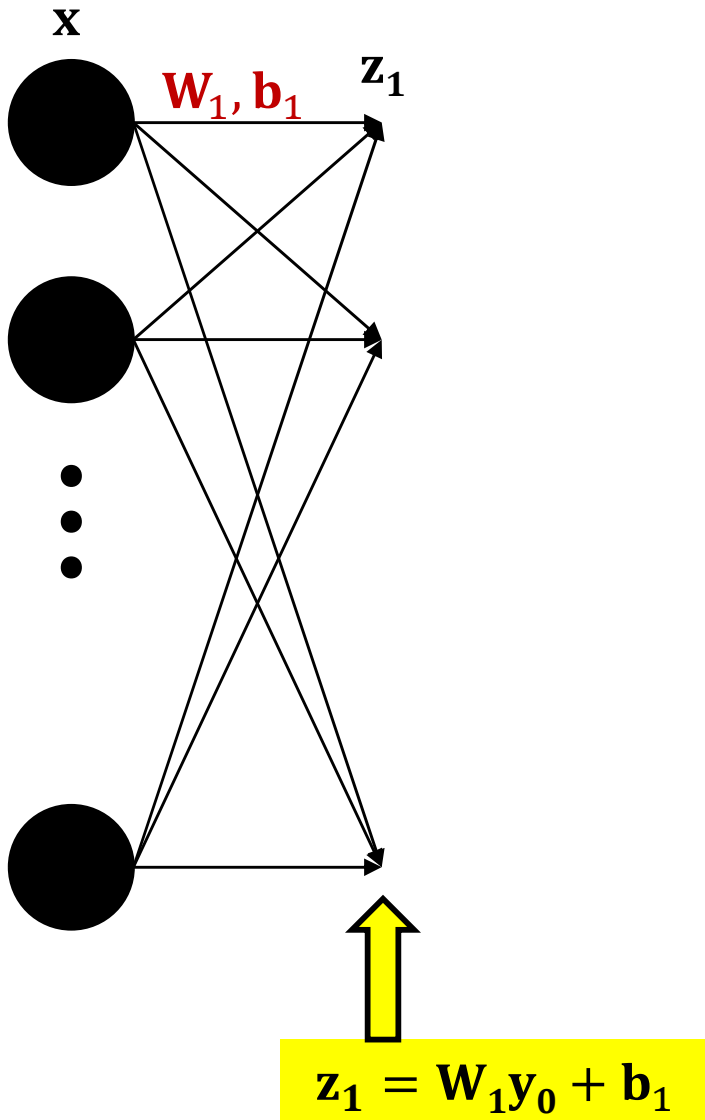

The forward pass

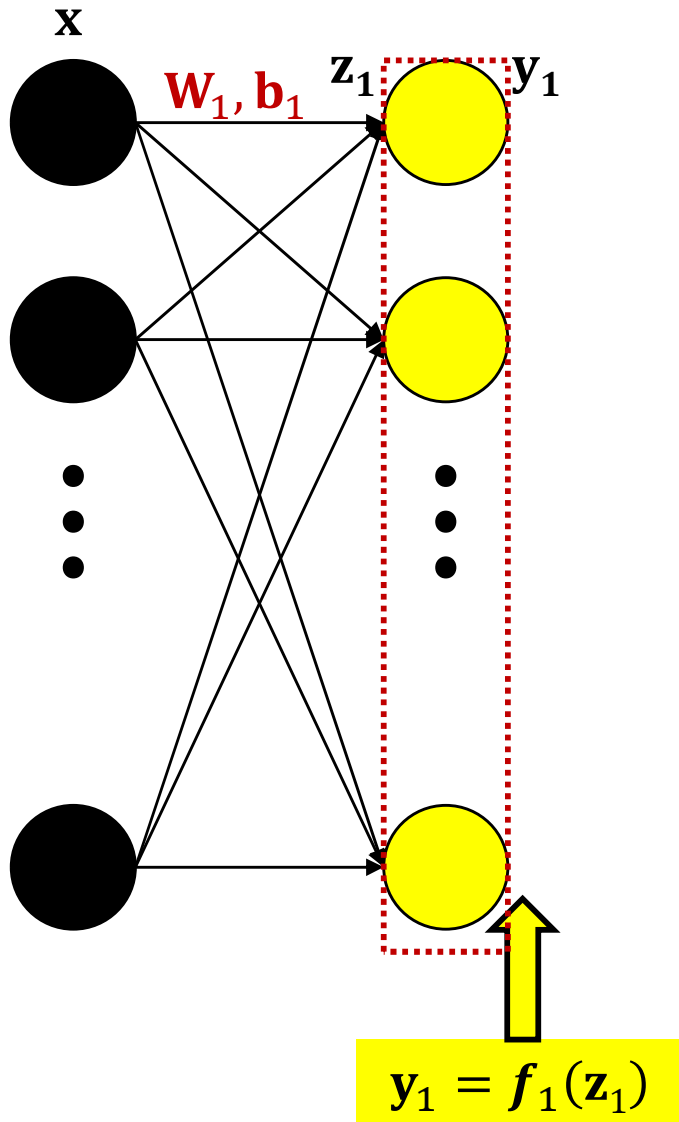

The Complete computation

$$y_1 = f_1(W_1x + b_1)$$

The forward pass

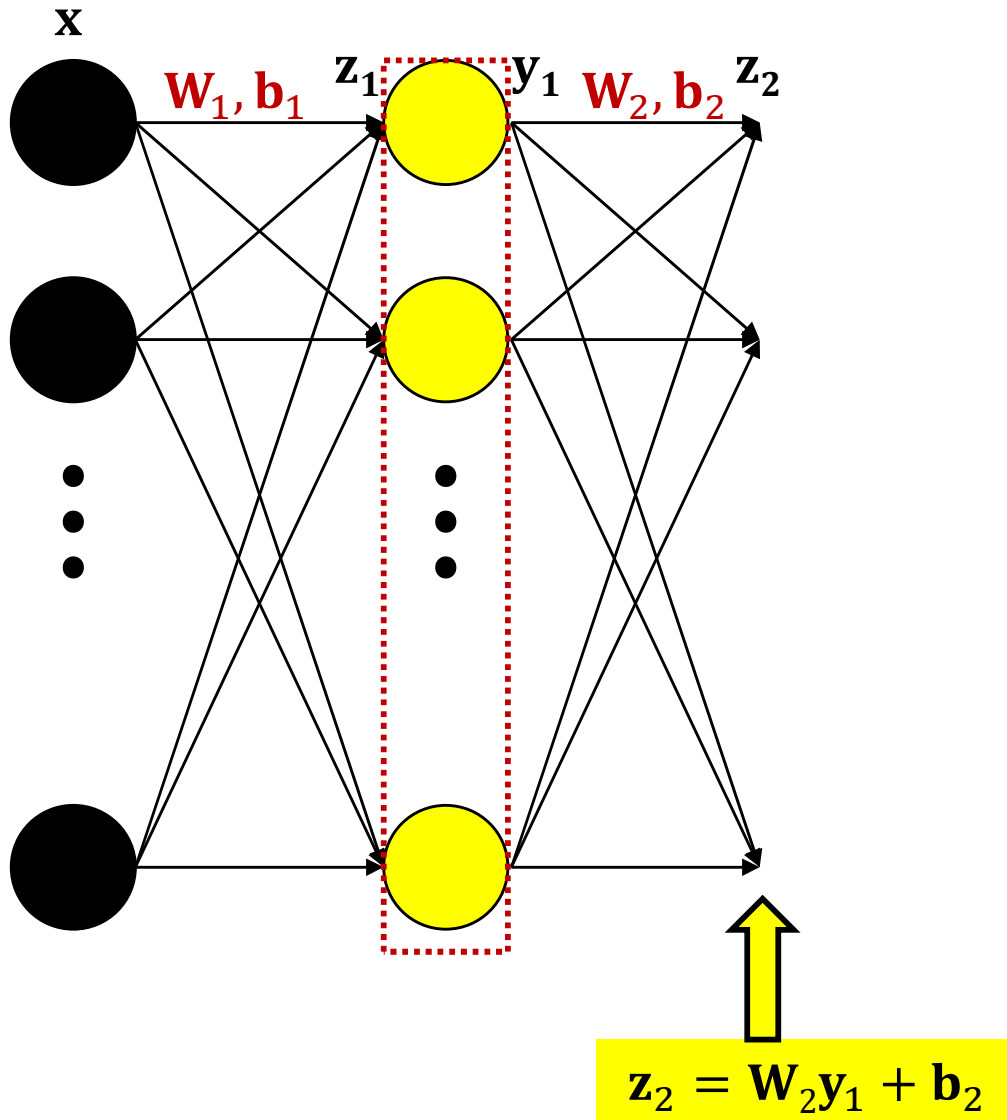

The Complete computation

$$y_1 = f_1(W_1 x + b_1)$$

The forward pass

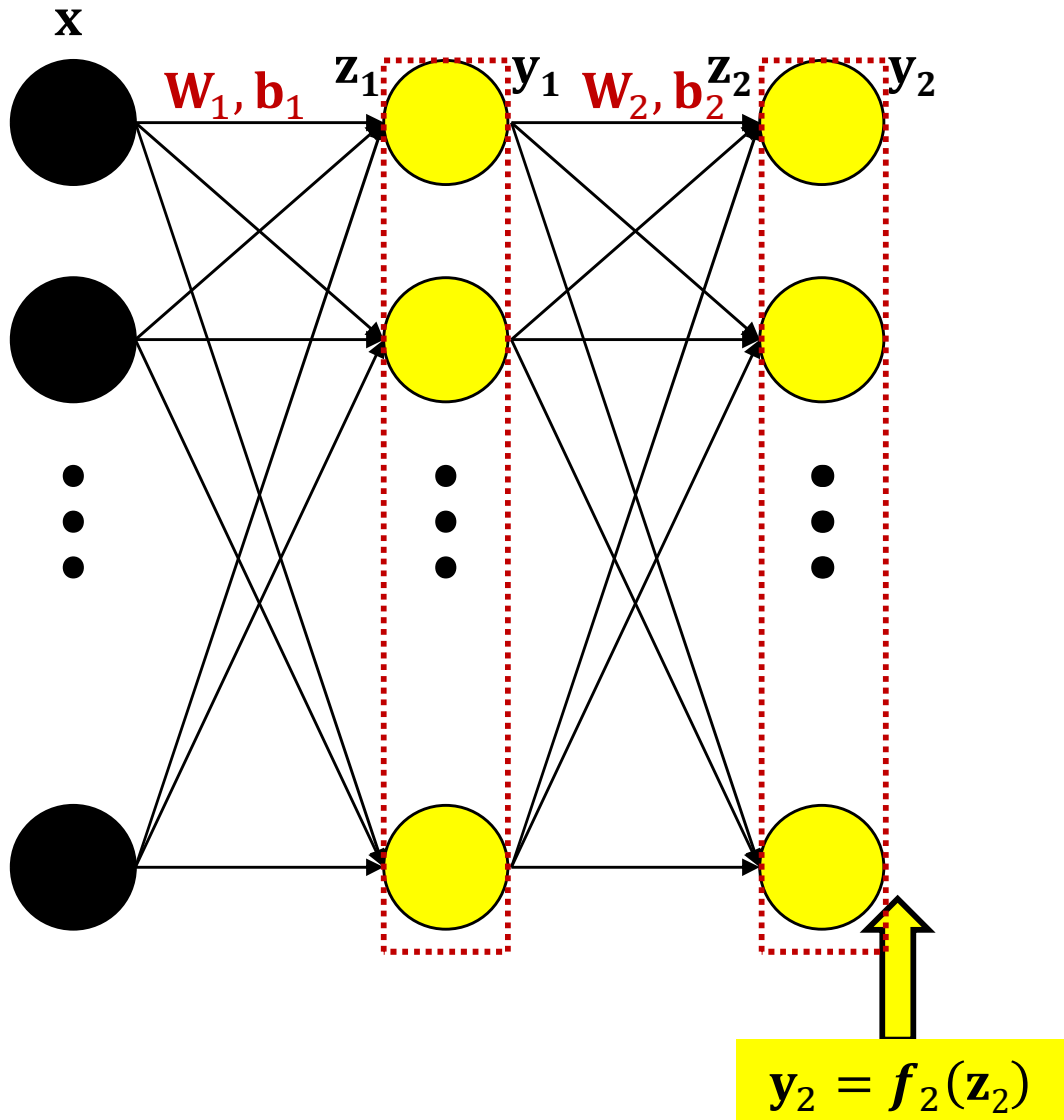

The Complete computation

$$y_2 = f_2(W_2 f_1(W_1 x + b_1) + b_2)$$

The forward pass

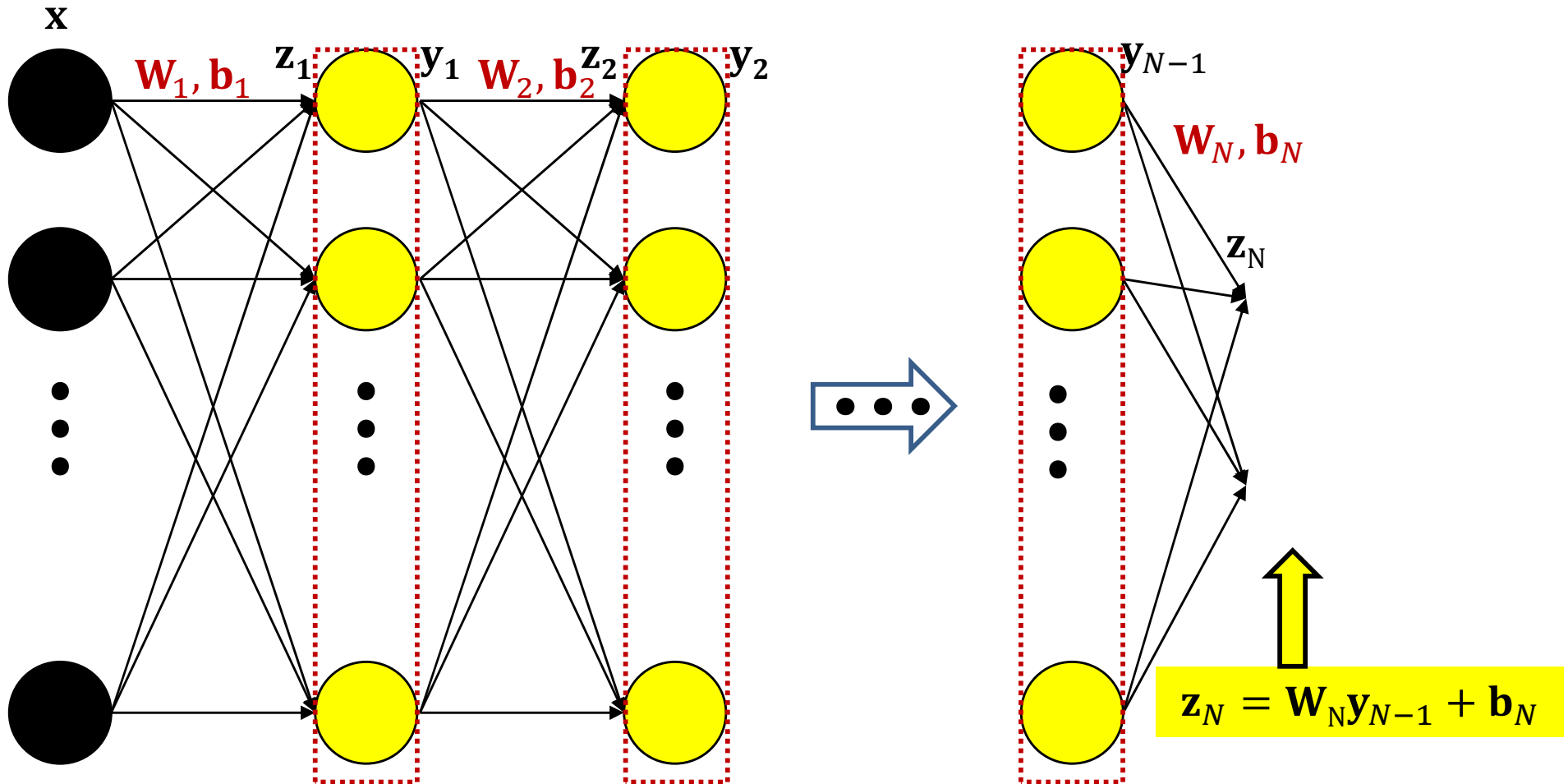

The Complete computation

$$\mathbf{z}_N = \mathbf{W}_N f_{N-1}(\dots f_2(\mathbf{W}_2 f_1(\mathbf{W}_1 \mathbf{x} + \mathbf{b}_1) + \mathbf{b}_2) \dots) + \mathbf{b}_N$$

The forward pass

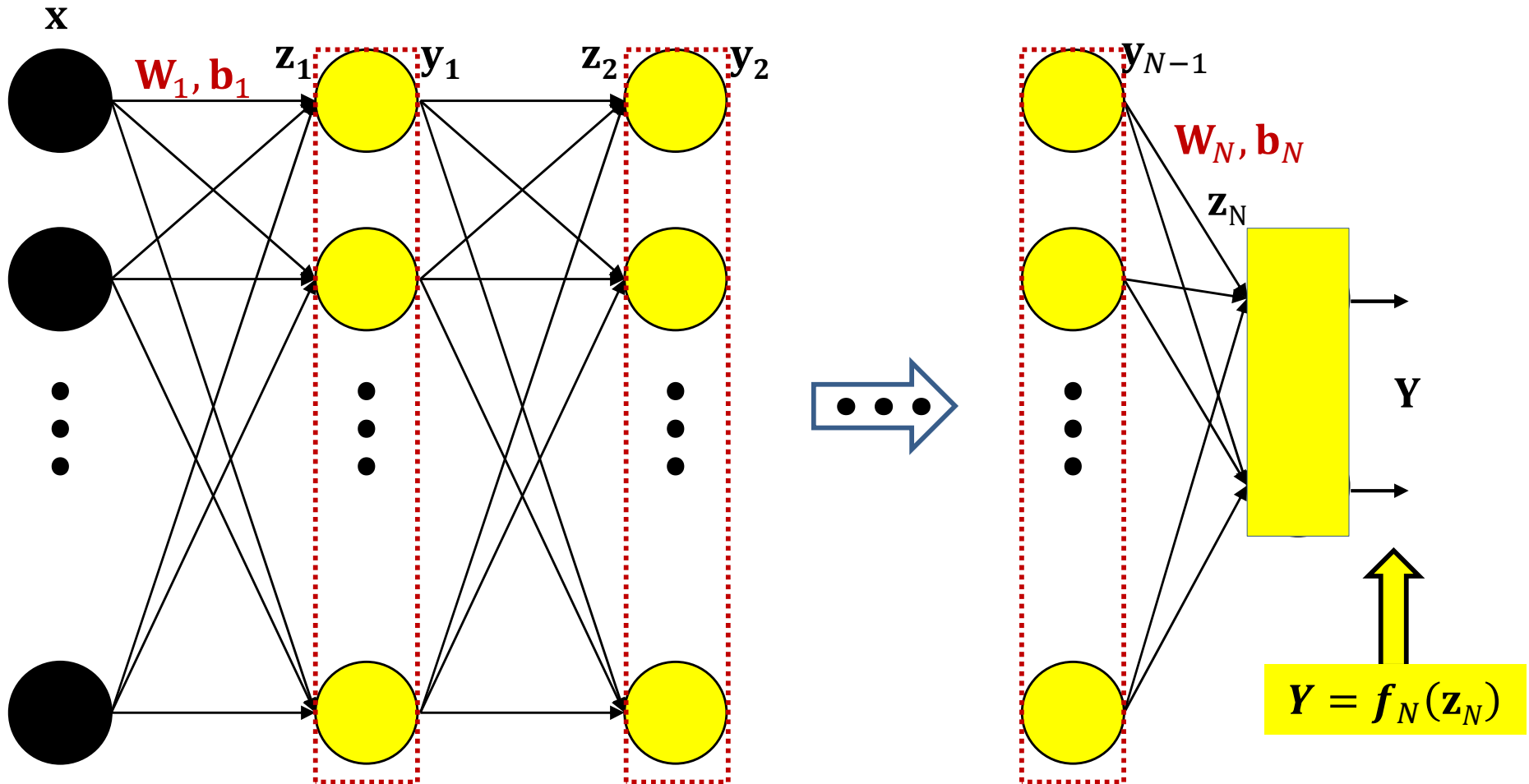

The Complete computation

$$Y = f_N(\mathbf{W}_N f_{N-1}(\dots f_2(\mathbf{W}_2 f_1(\mathbf{W}_1 \mathbf{x} + \mathbf{b}_1) + \mathbf{b}_2) \dots) + \mathbf{b}_N)$$

Forward pass

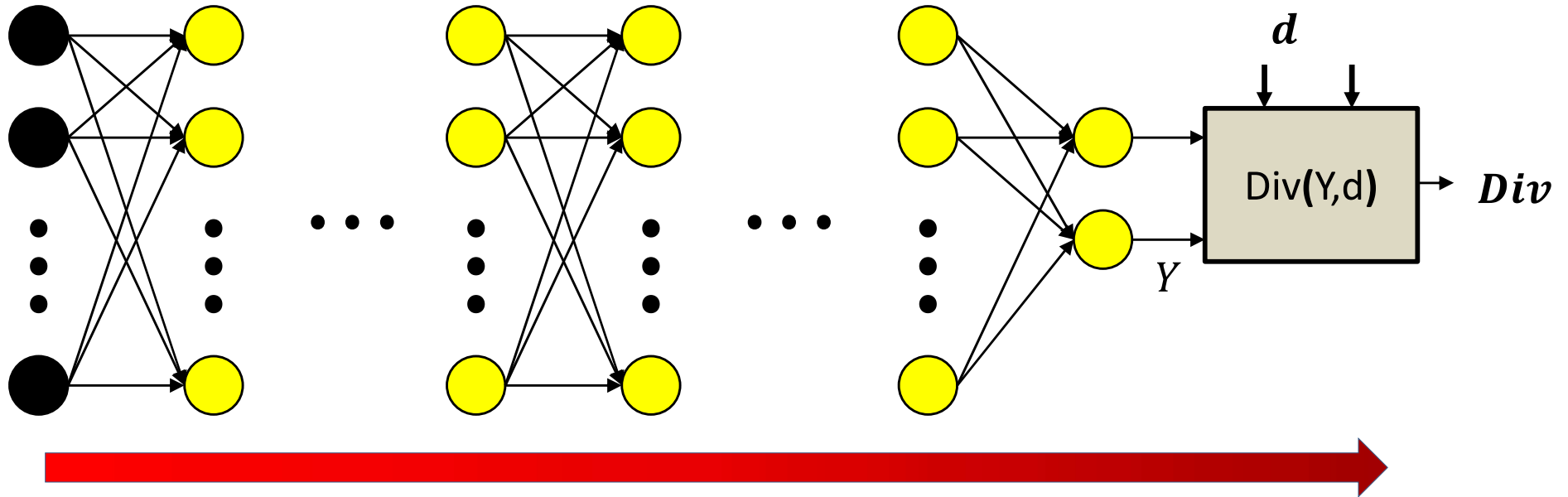

Forward pass:

Initialize

$$\mathbf{y}_0 = \mathbf{x}$$

For $k = 1$ to N :

$$\mathbf{z}_k = \mathbf{W}_k \mathbf{y}_{k-1} + \mathbf{b}_k$$

$$\mathbf{y}_k = f_k(\mathbf{z}_k)$$

Output

$$Y = \mathbf{y}_N$$

The Forward Pass

- Set $\mathbf{y}_0 = \mathbf{x}$
- Iterate through layers:

– For layer $k = 1$ to N :

$$\mathbf{z}_k = \mathbf{W}_k \mathbf{y}_{k-1} + \mathbf{b}_k$$

$$\mathbf{y}_k = \mathbf{f}_k(\mathbf{z}_k)$$

- Output:

$$\mathbf{Y} = \mathbf{y}_N$$

The Backward Pass

- Have completed the forward pass
- Before presenting the backward pass, some more calculus...
 - *Vector* calculus this time

Vector Calculus Notes 1: Definitions

- *A derivative is a multiplicative factor that multiplies a perturbation in the input to compute the corresponding perturbation of the output*

- **For a scalar function of a vector argument**

$$y = f(\mathbf{z})$$

$$\Delta y = \nabla_{\mathbf{z}} y \Delta \mathbf{z}$$

- If \mathbf{z} is an $R \times 1$ vector, $\nabla_{\mathbf{z}} y$ is a $1 \times R$ vector
 - The shape of the derivative is the *transpose* of the shape of \mathbf{z}
- $\nabla_{\mathbf{z}} y^T$ is called the *gradient* of y w.r.t \mathbf{z}

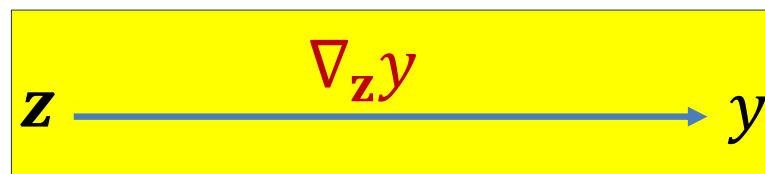

(influence diagram)

Vector Calculus Notes 1: Definitions

- For a *vector* function of a vector argument

$$\mathbf{y} = f(\mathbf{z})$$

$$\begin{bmatrix} y_1 \\ y_2 \\ \vdots \\ y_M \end{bmatrix} = f \left(\begin{bmatrix} z_1 \\ z_2 \\ \vdots \\ z_D \end{bmatrix} \right)$$

$$\Delta \mathbf{y} = \nabla_{\mathbf{z}} \mathbf{y} \Delta \mathbf{z}$$

- If \mathbf{z} is an $R \times 1$ vector, and \mathbf{y} is an $L \times 1$ $\nabla_{\mathbf{z}} \mathbf{y}$ is an $L \times R$ matrix
 - Or the dimensions won't match
- $\nabla_{\mathbf{z}} \mathbf{y}$ is called the *Jacobian* of \mathbf{y} w.r.t \mathbf{z}

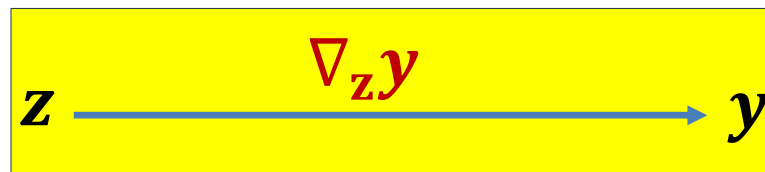

Calculus Notes: The Jacobian

- The derivative of a vector function w.r.t. vector input is called a *Jacobian*
- It is the matrix of partial derivatives given below

$$\begin{bmatrix} y_1 \\ y_2 \\ \vdots \\ y_M \end{bmatrix} = f \left(\begin{bmatrix} z_1 \\ z_2 \\ \vdots \\ z_D \end{bmatrix} \right)$$

Using vector notation

$$\mathbf{y} = f(\mathbf{z})$$

$$J_{\mathbf{y}}(\mathbf{z}) = \begin{bmatrix} \frac{\partial y_1}{\partial z_1} & \frac{\partial y_1}{\partial z_2} & \cdots & \frac{\partial y_1}{\partial z_D} \\ \frac{\partial y_2}{\partial z_1} & \frac{\partial y_2}{\partial z_2} & \cdots & \frac{\partial y_2}{\partial z_D} \\ \cdots & \cdots & \ddots & \cdots \\ \frac{\partial y_M}{\partial z_1} & \frac{\partial y_M}{\partial z_2} & \cdots & \frac{\partial y_M}{\partial z_D} \end{bmatrix}$$

Check:

$$\Delta \mathbf{y} = J_{\mathbf{y}}(\mathbf{z}) \Delta \mathbf{z}$$

Jacobians can describe the derivatives of neural activations w.r.t their input

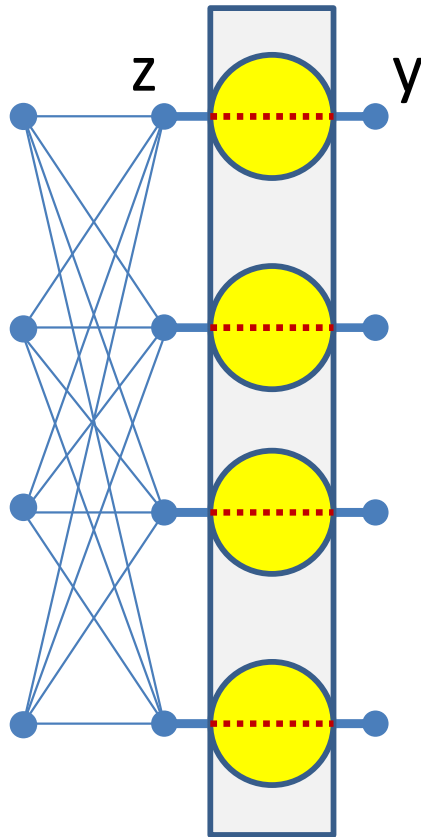

$$y_i = f(z_i)$$

$$J_y(\mathbf{z}) = \begin{bmatrix} f'(z_1) & 0 & \dots & 0 \\ 0 & f'(z_2) & \dots & 0 \\ \dots & \dots & \ddots & \dots \\ 0 & 0 & \dots & f'(z_M) \end{bmatrix}$$

- **For scalar activations (shorthand notation):**
 - Jacobian is a diagonal matrix
 - Diagonal entries are individual derivatives of outputs w.r.t inputs

For *Vector* activations

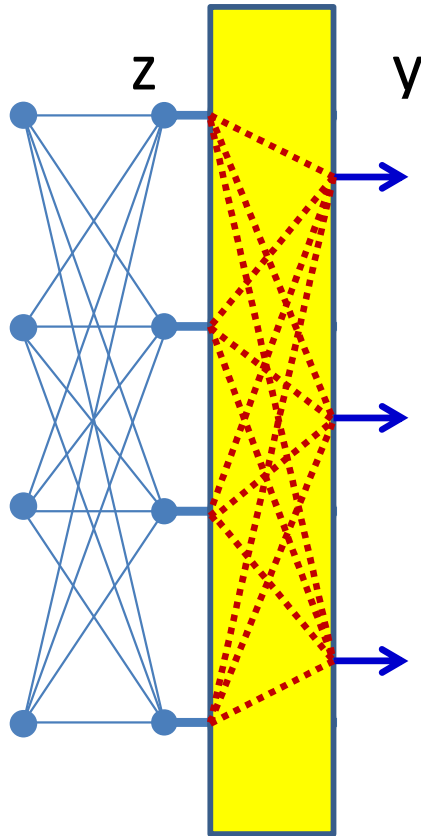

$$J_y(\mathbf{z}) = \begin{bmatrix} \frac{\partial y_1}{\partial z_1} & \frac{\partial y_1}{\partial z_2} & \dots & \frac{\partial y_1}{\partial z_D} \\ \frac{\partial y_2}{\partial z_1} & \frac{\partial y_2}{\partial z_2} & \dots & \frac{\partial y_2}{\partial z_D} \\ \dots & \dots & \ddots & \dots \\ \frac{\partial y_M}{\partial z_1} & \frac{\partial y_M}{\partial z_2} & \dots & \frac{\partial y_M}{\partial z_D} \end{bmatrix}$$

- Jacobian is a full matrix
 - Entries are partial derivatives of individual outputs w.r.t individual inputs

Special case: Affine functions

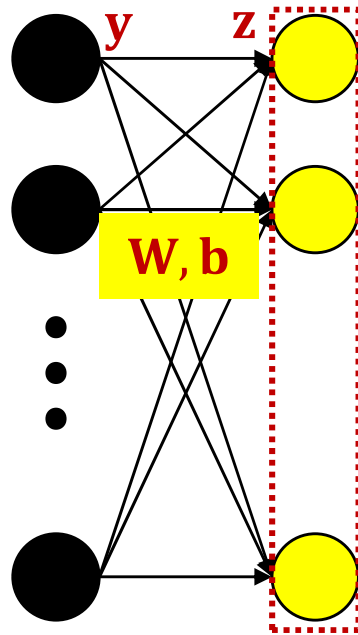

$$\mathbf{z} = \mathbf{W}\mathbf{y} + \mathbf{b}$$



$$\nabla_{\mathbf{y}}\mathbf{z} = J_{\mathbf{z}}(\mathbf{y}) = \mathbf{W}$$

$$\nabla_{\mathbf{b}}\mathbf{z} = J_{\mathbf{z}}(\mathbf{b}) = \mathbf{I}$$

- Matrix \mathbf{W} and bias \mathbf{b} operating on vector \mathbf{y} to produce vector \mathbf{z}
- The Jacobian of \mathbf{z} w.r.t \mathbf{y} is simply the matrix \mathbf{W}

Vector Calculus Notes 2: Chain rule

- For nested functions we have the following chain rule

$$y = y(z(x))$$

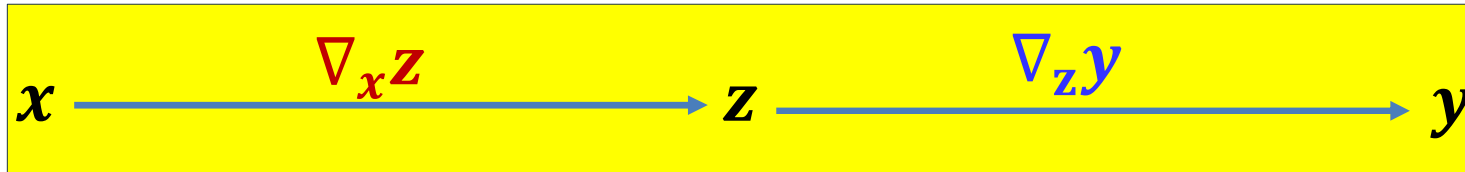

$$\nabla_x y = \nabla_z y \nabla_x z$$

This holds regardless of whether y is scalar or vector

Note the order: The derivative of the outer function comes first

Vector Calculus Notes 2: Chain rule

- For nested functions we have the following chain rule

$$y = y(z(x)) \quad \Rightarrow \quad \nabla_x y = \nabla_z y \nabla_x z$$

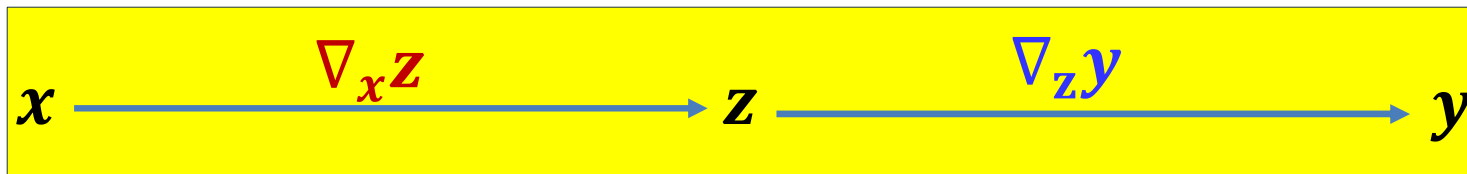

Check

$$\Delta y = \nabla_z y \Delta z$$

$$\Delta z = \nabla_x z \Delta x$$

$$\Delta y = \nabla_z y \nabla_x z \Delta x$$

Note the order: The derivative of the outer function comes first

Vector Calculus Notes 2: Chain rule

- Chain rule for Jacobians:
- **For vector functions of vector inputs:**

$$\mathbf{y} = \mathbf{y}(\mathbf{z}(\mathbf{x})) \quad \longrightarrow \quad J_{\mathbf{y}}(\mathbf{x}) = J_{\mathbf{y}}(\mathbf{z})J_{\mathbf{z}}(\mathbf{x})$$

Check

$$\Delta \mathbf{y} = J_{\mathbf{y}}(\mathbf{z})\Delta \mathbf{z}$$

$$\Delta \mathbf{z} = J_{\mathbf{z}}(\mathbf{x})\Delta \mathbf{x}$$

$$\Delta \mathbf{y} = J_{\mathbf{y}}(\mathbf{z})J_{\mathbf{z}}(\mathbf{x})\Delta \mathbf{x} = J_{\mathbf{y}}(\mathbf{x})\Delta \mathbf{x}$$

Note the order: The derivative of the outer function comes first

Vector Calculus Notes 2: Chain rule

- *Combining Jacobians and Gradients*
- **For *scalar* functions of vector inputs ($\mathbf{z}()$ is vector):**

$$D = D(\mathbf{y}(\mathbf{z})) \quad \longrightarrow \quad \nabla_{\mathbf{z}} D = \nabla_{\mathbf{y}}(D) J_{\mathbf{y}}(\mathbf{z})$$

Check

$$\Delta D = \nabla_{\mathbf{y}}(D) \Delta \mathbf{y}$$

$$\Delta \mathbf{y} = J_{\mathbf{y}}(\mathbf{z}) \Delta \mathbf{z}$$

$$\Delta D = \nabla_{\mathbf{y}}(D) J_{\mathbf{y}}(\mathbf{z}) \Delta \mathbf{z} = \nabla_{\mathbf{z}} D \Delta \mathbf{z}$$

Note the order: The derivative of the outer function comes first

Extended Chain rule

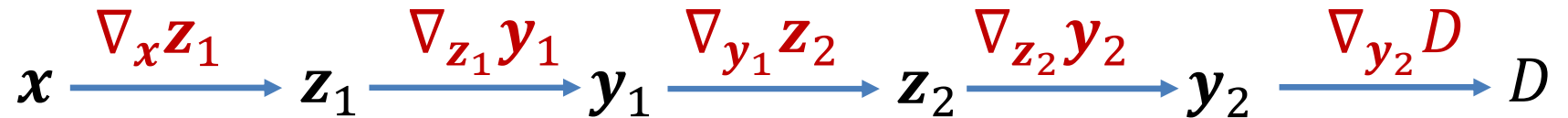

How do we compute the derivative of D w.r.t. x , z_1 , y_1 , z_2 and y_2 , from the local derivatives shown on the edges?

Extended Chain rule

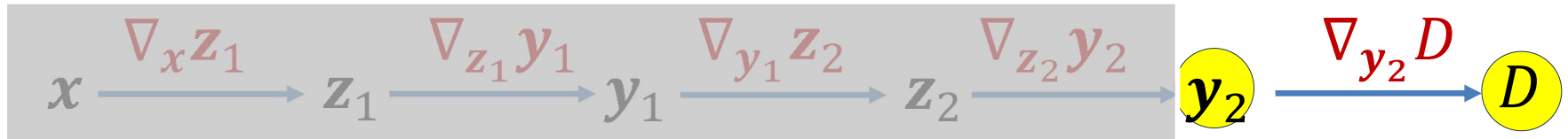

Extended Chain rule

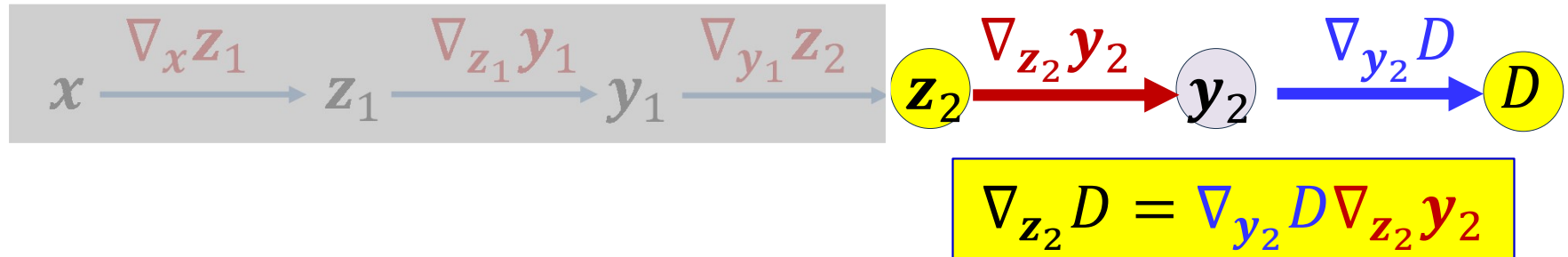

Note the order: The derivative of the outer function comes first

Extended Chain rule

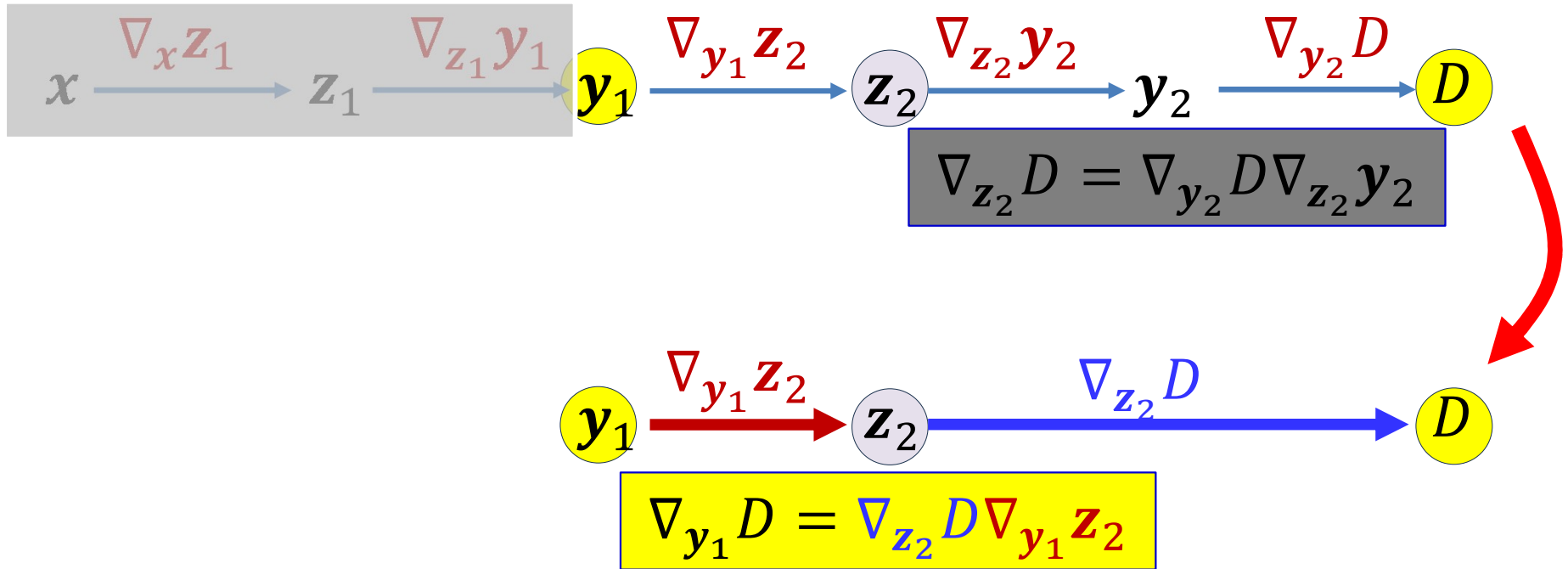

Note the order: The derivative of the outer function comes first

Extended Chain rule

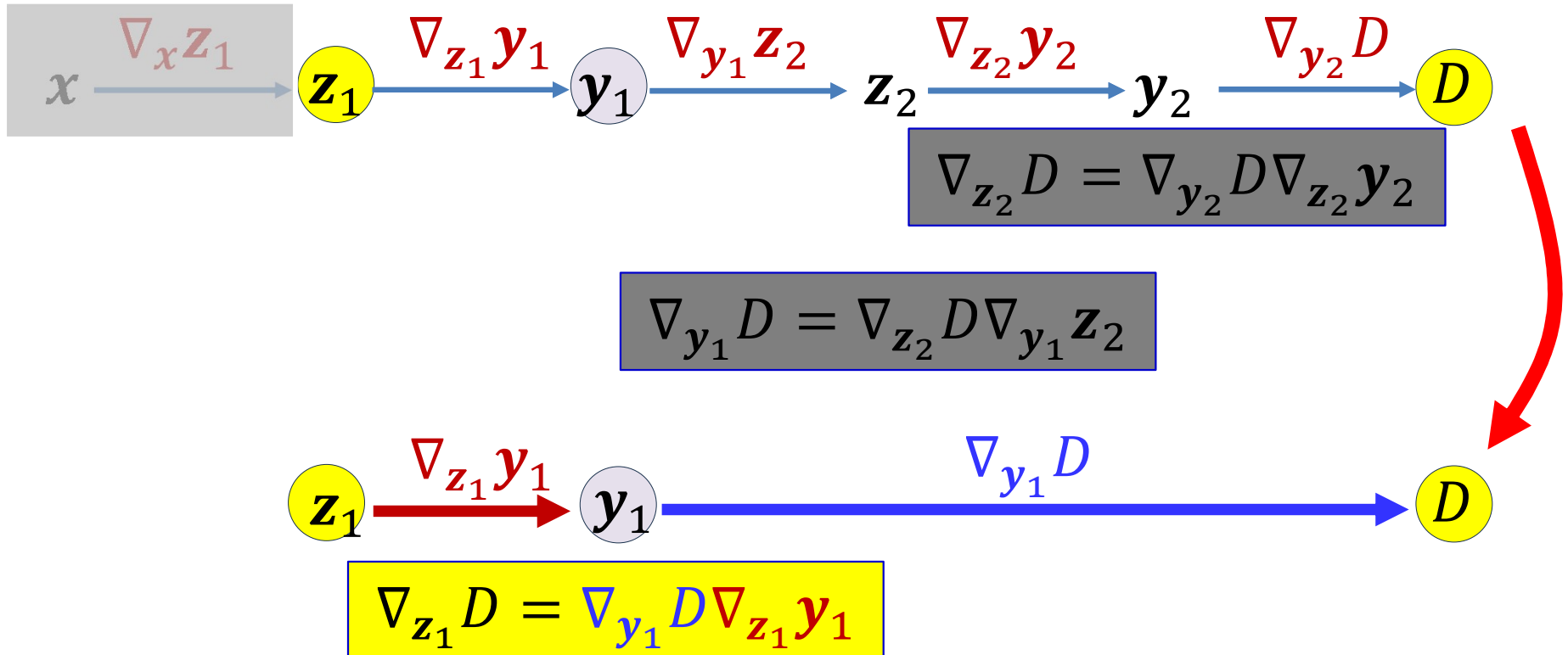

Note the order: The derivative of the outer function comes first

Extended Chain rule

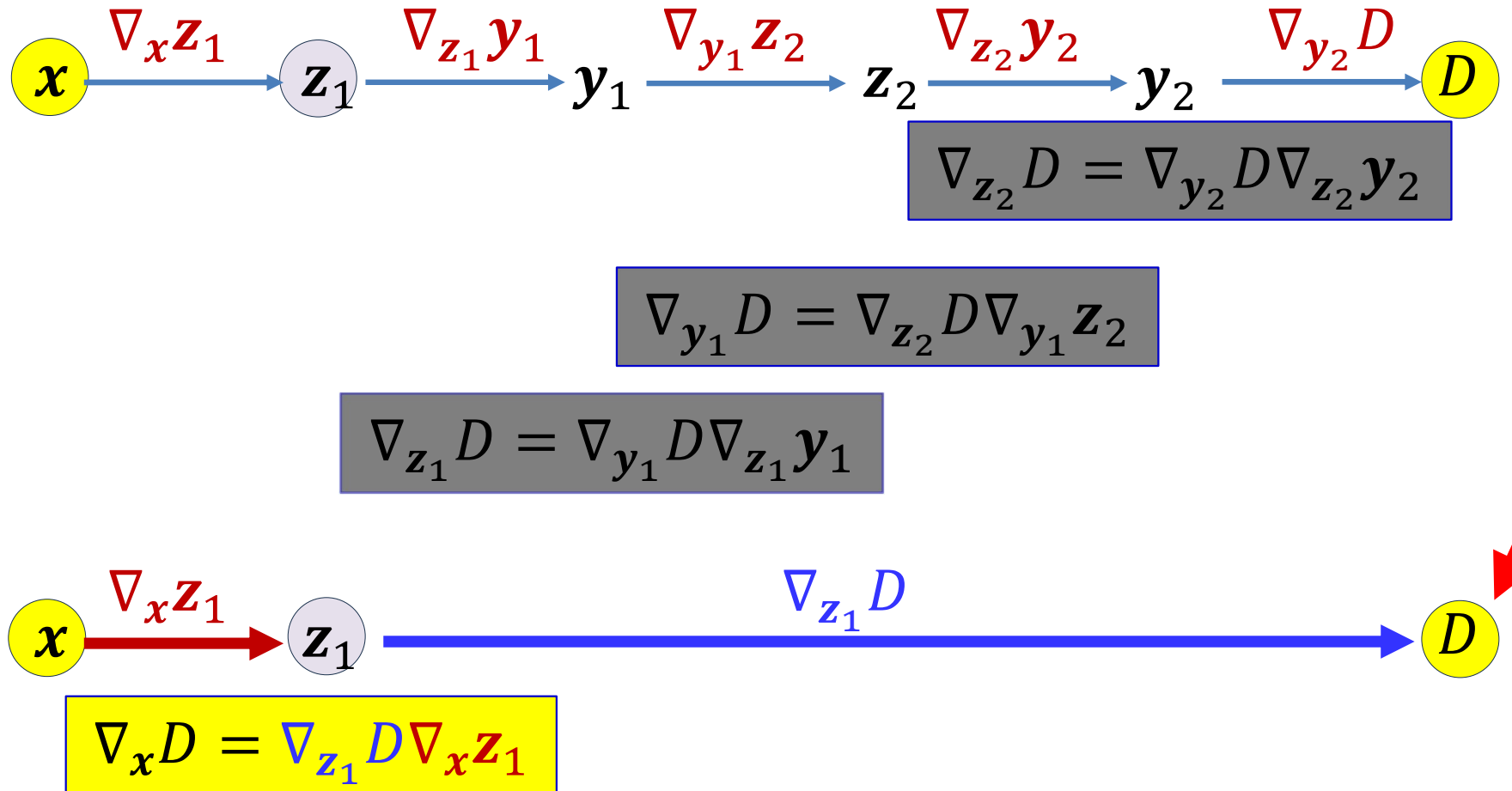

Note the order: The derivative of the outer function comes first

Extended Chain rule

$$x \xrightarrow{\nabla_x z_1} z_1 \xrightarrow{\nabla_{z_1} y_1} y_1 \xrightarrow{\nabla_{y_1} z_2} z_2 \xrightarrow{\nabla_{z_2} y_2} y_2 \xrightarrow{\nabla_{y_2} D} D$$

$$\nabla_{z_2} D = \nabla_{y_2} D \nabla_{z_2} y_2$$

$$\nabla_{y_1} D = \nabla_{z_2} D \nabla_{y_1} z_2$$

$$\nabla_{z_1} D = \nabla_{y_1} D \nabla_{z_1} y_1$$

$$\nabla_x D = \nabla_{z_1} D \nabla_x z_1$$

Note the order: The derivative of the outer function comes first

Vector Calculus Notes 2: Chain rule

- For nested functions we have the following chain rule

$$D = D \left(\mathbf{y}_N \left(\mathbf{z}_N \left(\mathbf{y}_{N-1} \left(\mathbf{z}_{N-1} \left(\dots \mathbf{y}_1 \left(\mathbf{z}_1(\mathbf{x}) \right) \right) \right) \right) \right) \right) \right)$$

$$\nabla_{\mathbf{x}} D = \nabla_{\mathbf{y}_N} D \nabla_{\mathbf{z}_N} \mathbf{y}_N \nabla_{\mathbf{y}_{N-1}} \mathbf{z}_N \nabla_{\mathbf{z}_{N-1}} \mathbf{y}_{N-1} \dots \nabla_{\mathbf{z}_1} \mathbf{y}_1 \nabla_{\mathbf{x}} \mathbf{z}_1$$

Note the order: The derivative of the outer function comes first

Vector Calculus Notes 2: Chain rule

- For nested functions we have the following chain rule

$$D = D \left(\underline{\mathbf{y}_N} \left(\underline{\mathbf{z}_N} \left(\underline{\mathbf{y}_{N-1}} \left(\underline{\mathbf{z}_{N-1}} \left(\dots \mathbf{y}_1 \left(\mathbf{z}_1(\mathbf{x}) \right) \right) \right) \right) \right) \right) \right)$$

$$\nabla_{\mathbf{x}} D = \underline{\nabla_{\mathbf{y}_N} D} \underline{\nabla_{\mathbf{z}_N} \mathbf{y}_N} \underline{\nabla_{\mathbf{y}_{N-1}} \mathbf{z}_N} \underline{\nabla_{\mathbf{z}_{N-1}} \mathbf{y}_{N-1}} \dots \nabla_{\mathbf{z}_1} \mathbf{y}_1 \nabla_{\mathbf{x}} \mathbf{z}_1$$

Note the order: The derivative of the outer function comes first

More calculus: Special Case

- Scalar functions of Affine functions

$$\mathbf{z} = \mathbf{W}\mathbf{y} + \mathbf{b}$$

$$D = f(\mathbf{z})$$

$$\mathbf{y} \xrightarrow{\mathbf{W}} \mathbf{z} \xrightarrow{\nabla_{\mathbf{z}} D} D$$

$$\nabla_{\mathbf{y}} D = \nabla_{\mathbf{z}} D \mathbf{W}$$

More calculus: Special Case

- Scalar functions of Affine functions

$$\mathbf{z} = \mathbf{W}\mathbf{y} + \mathbf{b}$$

$$D = f(\mathbf{z})$$

$$\mathbf{y} \xrightarrow{\mathbf{W}} \mathbf{z} \xrightarrow{\nabla_{\mathbf{z}} D} D$$

$$\nabla_{\mathbf{y}} D = \nabla_{\mathbf{z}} D \mathbf{W}$$

$$\nabla_{\mathbf{b}} D = \nabla_{\mathbf{z}} D \nabla_{\mathbf{b}} \mathbf{z} = \nabla_{\mathbf{z}} D$$

More calculus: Special Case

- Scalar functions of Affine functions

$$\mathbf{z} = \mathbf{W}\mathbf{y} + \mathbf{b}$$

$$D = f(\mathbf{z})$$

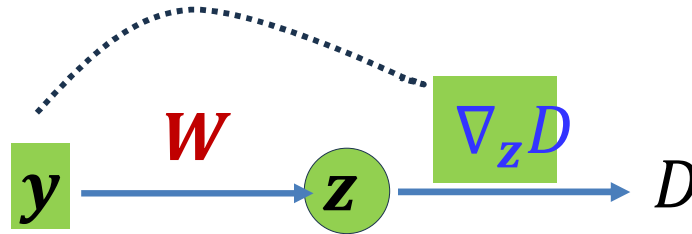

$$\nabla_y D = \nabla_z D \mathbf{W}$$

$$\nabla_b D = \nabla_z D$$

$$\nabla_W D = \mathbf{y} \nabla_z D$$

More calculus: Special Case

- Scalar functions of Affine functions

$$\mathbf{z} = \mathbf{W}\mathbf{y} + \mathbf{b}$$

$$D = f(\mathbf{z})$$

$$\nabla_{\mathbf{y}} D = \nabla_{\mathbf{z}}(D) \mathbf{W}$$

$$\nabla_{\mathbf{b}} D = \nabla_{\mathbf{z}}(D)$$

$$\nabla_{\mathbf{W}} D = \mathbf{y} \nabla_{\mathbf{z}}(D)$$

Derivatives w.r.t
parameters

- Note: the derivative shapes are the *transpose* of the shapes of \mathbf{W} and \mathbf{b}

More calculus: Special Case

- Scalar functions of Affine functions

$$\mathbf{z} = \mathbf{W}\mathbf{y} + \mathbf{b}$$

$$D = f(\mathbf{z})$$

- Writing the transpose

$$\mathbf{z}^\top = \mathbf{y}^\top \mathbf{W}^\top + \mathbf{b}^\top$$

$$\nabla_{\mathbf{W}^\top} \mathbf{z}^\top = \mathbf{y}^\top$$

$$\nabla_{\mathbf{W}^\top} D = \nabla_{\mathbf{z}^\top} D \nabla_{\mathbf{W}^\top} \mathbf{z}^\top = \nabla_{\mathbf{z}^\top} D \mathbf{y}^\top$$

$$\nabla_{\mathbf{W}} D = (\nabla_{\mathbf{W}^\top} D)^\top = \mathbf{y} \nabla_{\mathbf{z}} D$$

$$\nabla_{\mathbf{W}} D = \mathbf{y} \nabla_{\mathbf{z}}(D)$$

Special Case: Application to a network

- Scalar functions of Affine functions

$$\mathbf{z} = \mathbf{W}\mathbf{y} + \mathbf{b}$$

$$Div = Div(\mathbf{z})$$



$$\nabla_{\mathbf{y}} Div = \nabla_{\mathbf{z}} Div \mathbf{W}$$

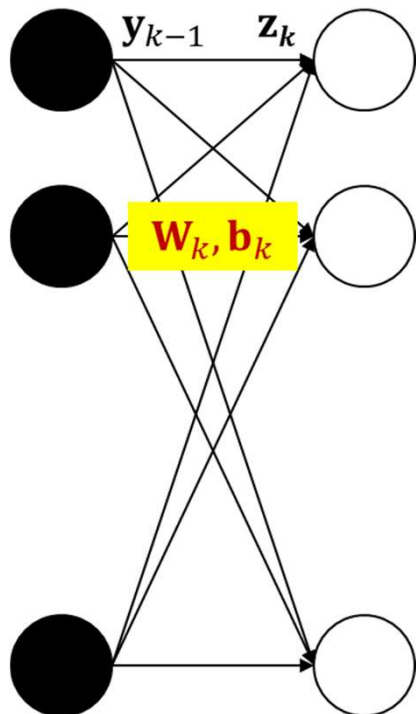

$$\mathbf{z}_k = \mathbf{W}_k \mathbf{y}_{k-1} + \mathbf{b}_k$$

The divergence is a scalar function of \mathbf{z}_k

Applying the above rule

$$\nabla_{\mathbf{y}_{k-1}} Div = \nabla_{\mathbf{z}_k} Div \mathbf{W}_k$$

Special Case: Application to a network

- Scalar functions of Affine functions

$$\mathbf{z} = \mathbf{W}\mathbf{y} + \mathbf{b}$$

$$Div = Div(\mathbf{z})$$



$$\nabla_{\mathbf{b}} Div = \nabla_{\mathbf{z}} Div$$

$$\nabla_{\mathbf{W}} Div = \mathbf{y} \nabla_{\mathbf{z}} Div$$

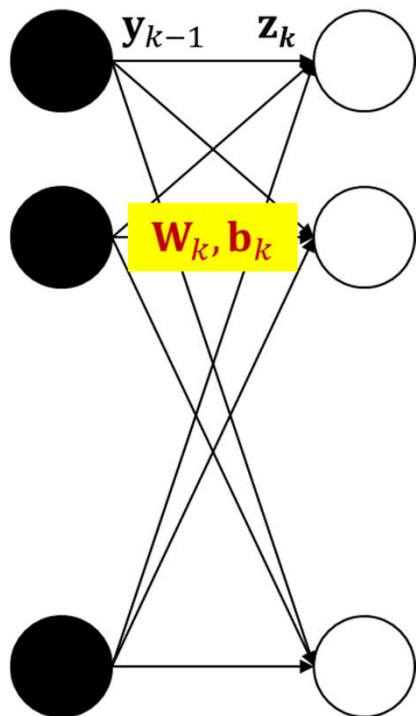

$$\mathbf{z}_k = \mathbf{W}_k \mathbf{y}_{k-1} + \mathbf{b}_k$$

$$\nabla_{\mathbf{b}_k} Div = \nabla_{\mathbf{z}_k} Div$$

$$\nabla_{\mathbf{W}_k} D = \mathbf{y}_{k-1} \nabla_{\mathbf{z}_k} Div$$

Poll 4 (@393)

We are given the function $Y = F(G(H(X)))$, where Y and X are vectors, and G and H also compute vector outputs.

Select the correct formula for the derivative of Y w.r.t. X . We use the notation $\nabla_X(Y)$ to represent the derivative of Y w.r.t X .

- $\nabla_X(H) \nabla_H(G) \nabla_G(F)$
- $\nabla_G(F) \nabla_H(G) \nabla_X(H)$
- Both are correct

Poll 4

We are given the function $Y = F(G(H(X)))$, where Y and X are vectors, and G and H also compute vector outputs.

Select the correct formula for the derivative of Y w.r.t. X . We use the notation $\nabla_X(Y)$ to represent the derivative of Y w.r.t X .

- $\nabla_X(H) \nabla_H(G) \nabla_G(F)$
- $\nabla_G(F) \nabla_H(G) \nabla_X(H)$ **(correct)**
- Both are correct

The backward pass

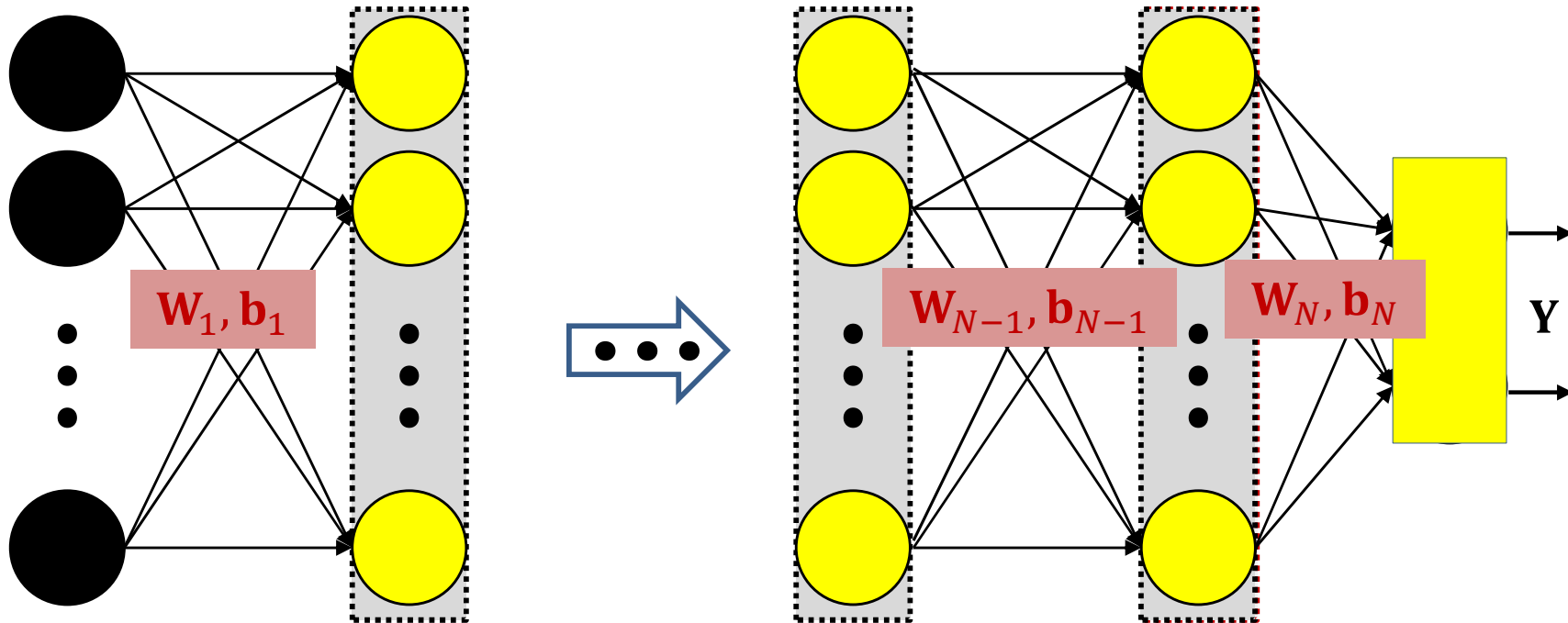

- The network again

The backward pass

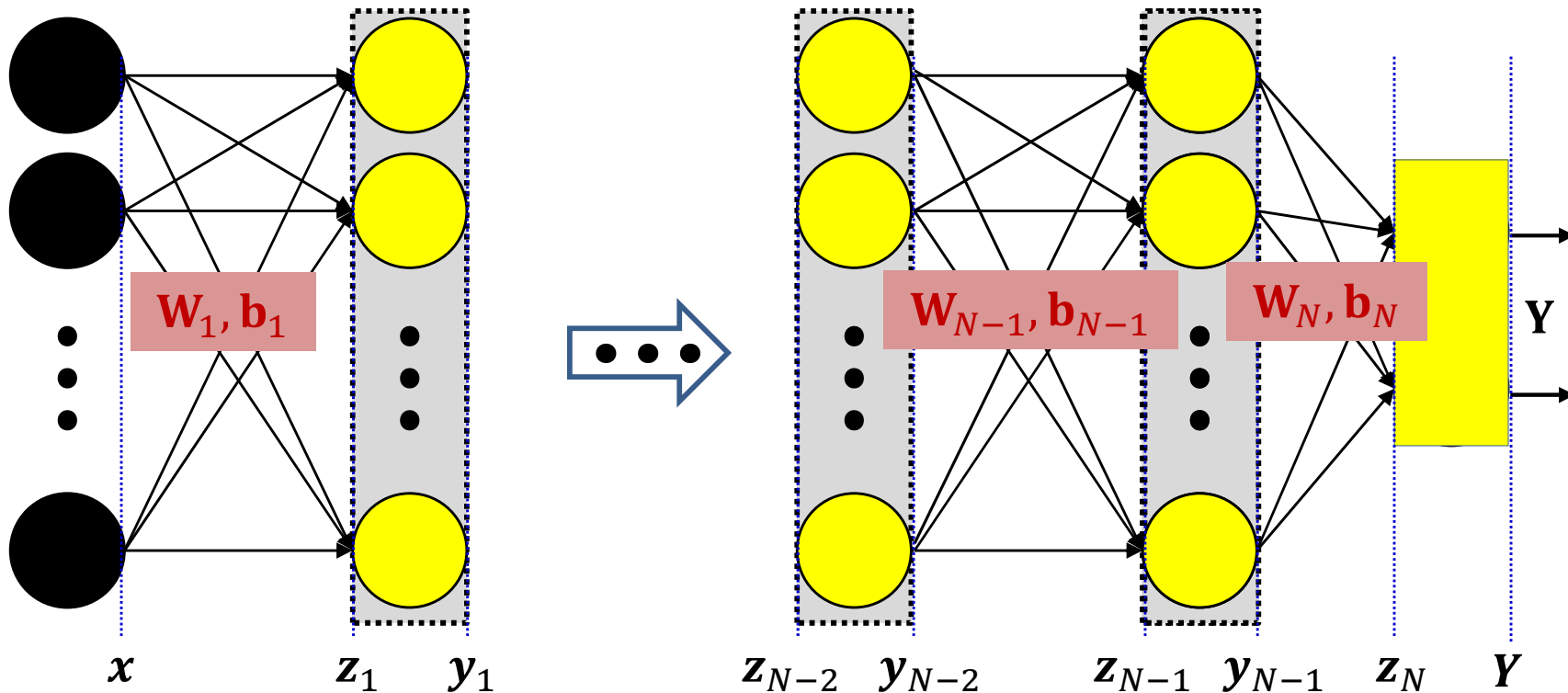

- The network again (with variables shown)...

The backward pass

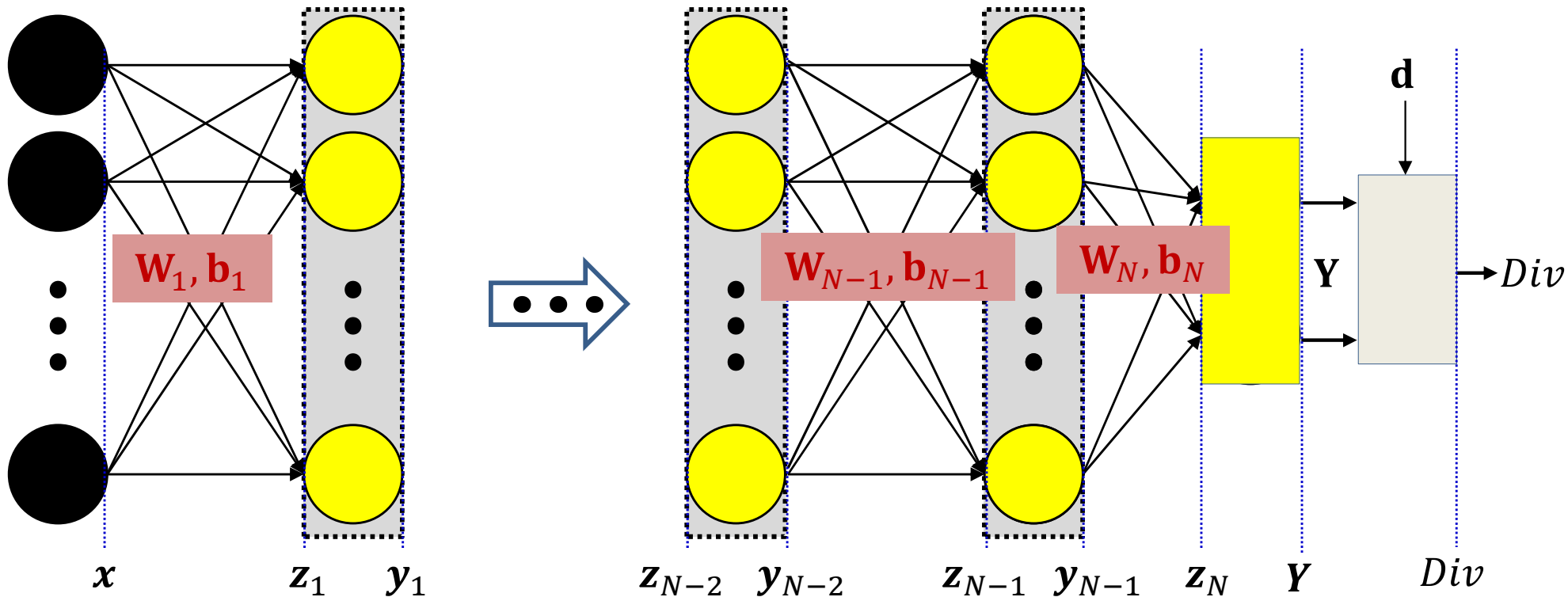

- The network again (with variables shown)...
- With the divergence we will minimize...

The backward pass

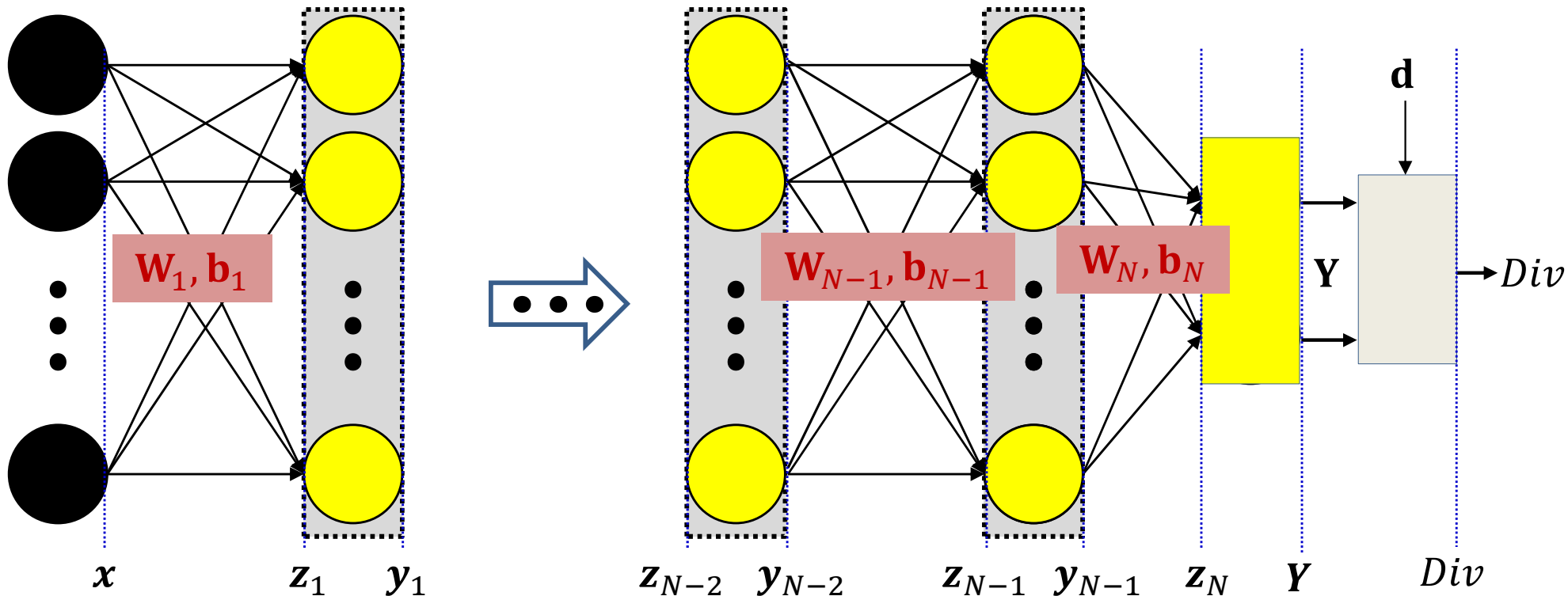

- The network is a nested function

$$Y = f_N(\mathbf{W}_N f_{N-1}(\dots f_2(\mathbf{W}_2 f_1(\mathbf{W}_1 \mathbf{x} + \mathbf{b}_1) + \mathbf{b}_2) \dots) + \mathbf{b}_N)$$

- The divergence for any \mathbf{x} is also a nested function

$$Div(Y, d) = Div(f_N(\mathbf{W}_N f_{N-1}(\dots f_2(\mathbf{W}_2 f_1(\mathbf{W}_1 \mathbf{x} + \mathbf{b}_1) + \mathbf{b}_2) \dots) + \mathbf{b}_N), d)$$

The backward pass

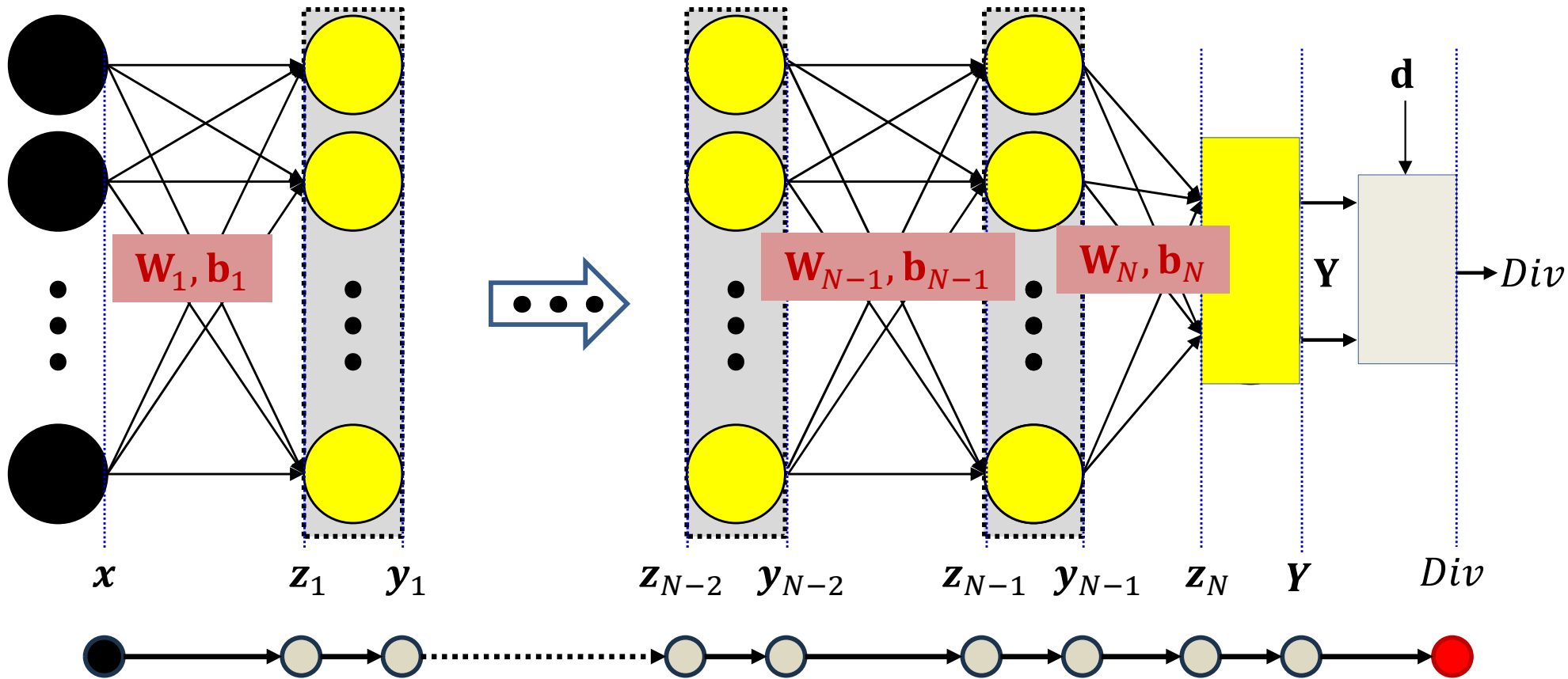

- The network again (with variables shown)...
- With the divergence we will minimize...
- And the entire influence diagram

The backward pass

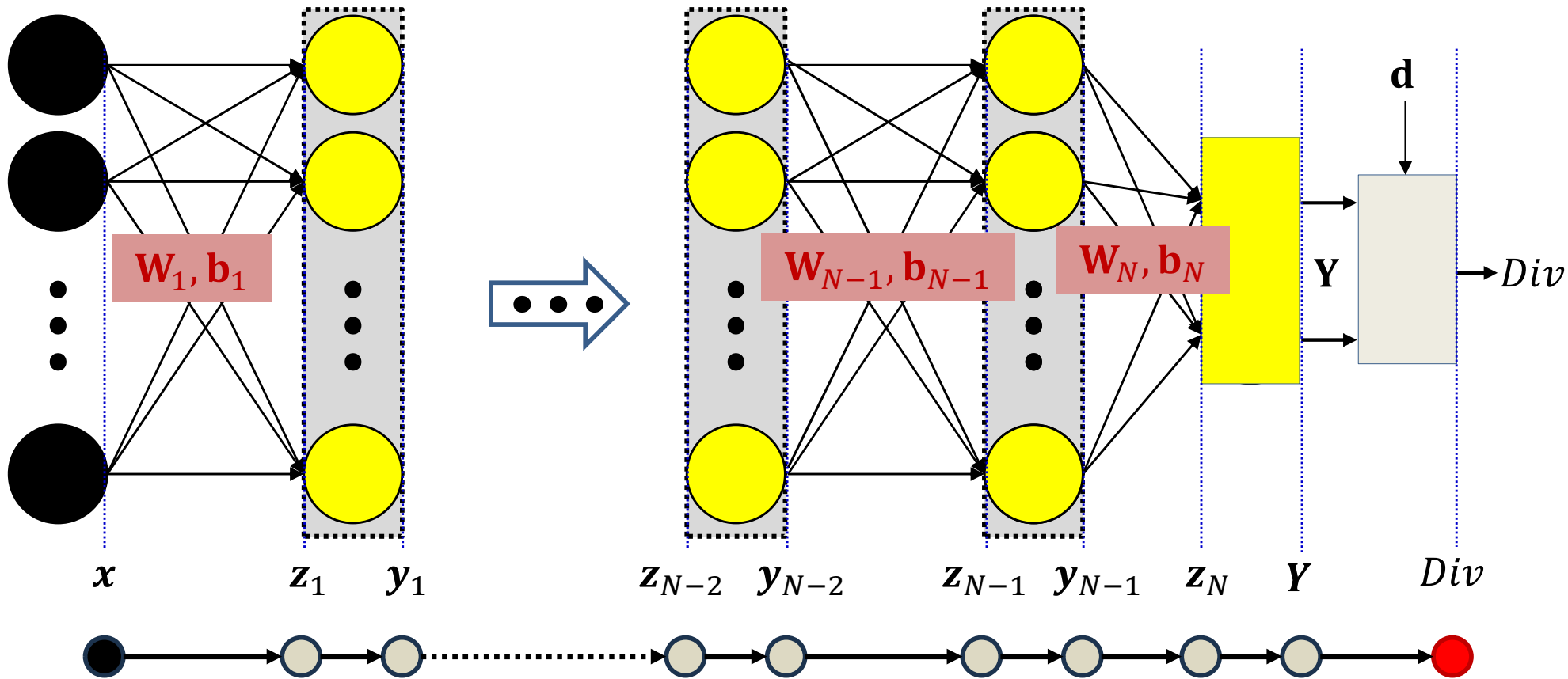

In the following slides we will also be using the notation $\nabla_{\mathbf{z}}\mathbf{y}$ to represent the derivative of any \mathbf{y} w.r.t any \mathbf{z}

Note that for activation functions, these are actually Jacobians

The backward pass

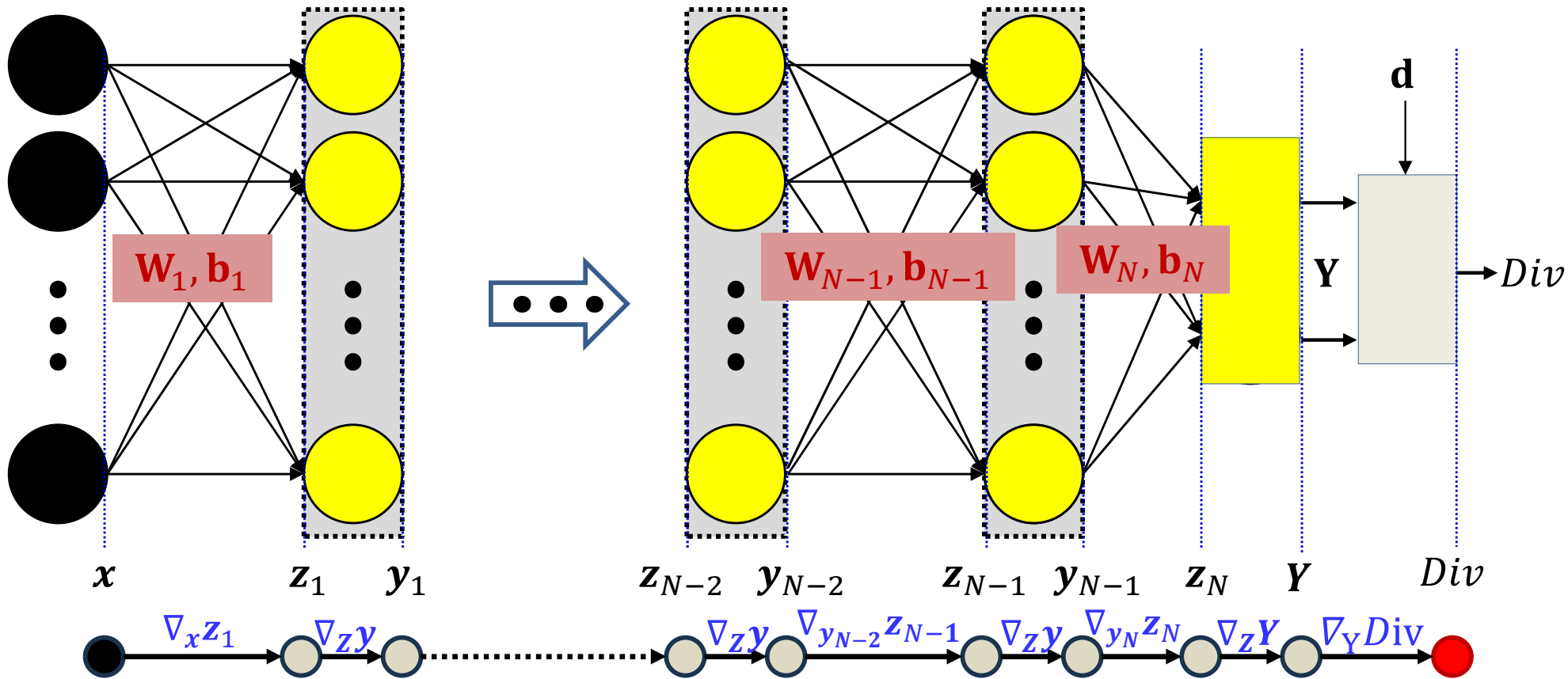

- The network again (with variables shown)...
- With the divergence we will minimize...
- And the entire influence diagram (with derivatives)
 - Variable subscripts not shown in $\nabla_{z} y$ for brevity

The backward pass

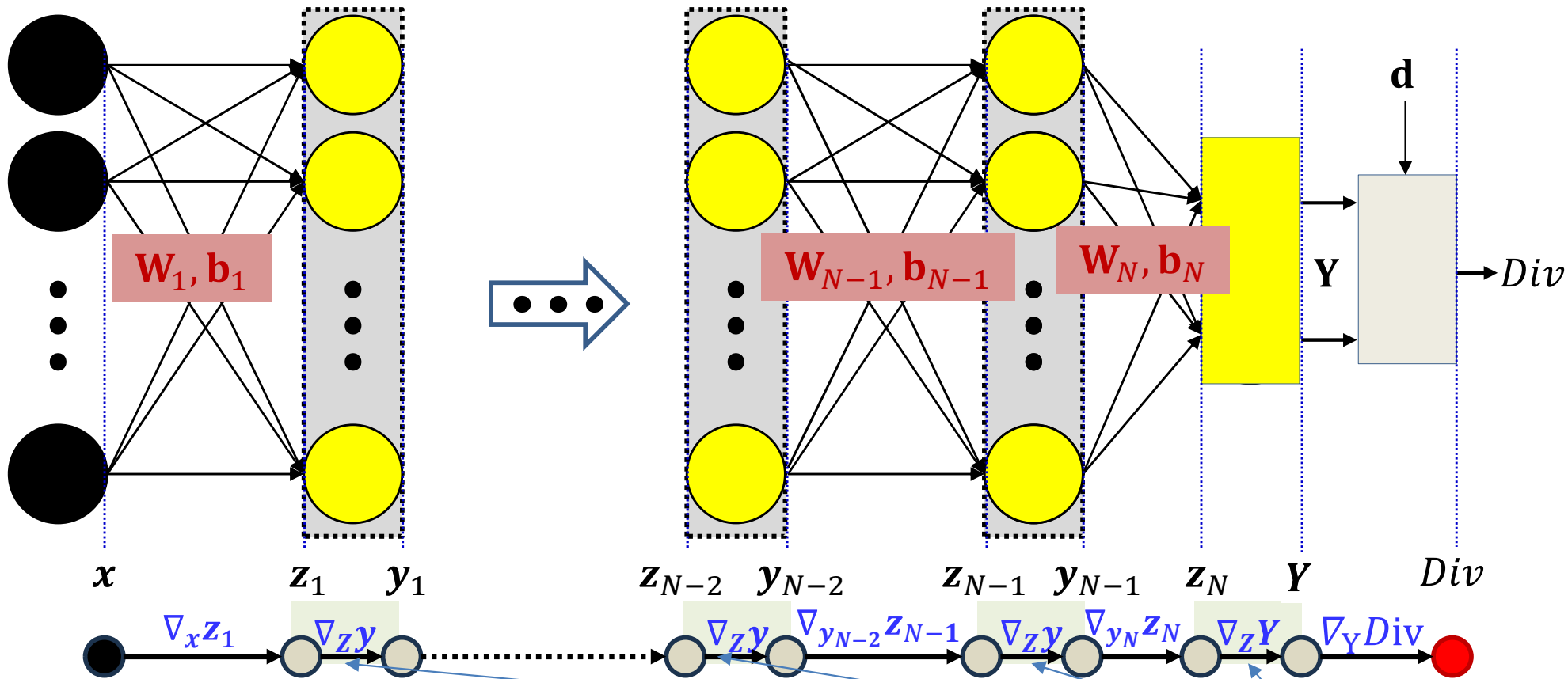

- The network again (with variables shown)...
- With the divergence we will minimize...
- And the entire influence diagram (with derivatives)
 - Variable subscripts not shown in $\nabla_{z}y$ for brevity

These are Jacobians

The backward pass

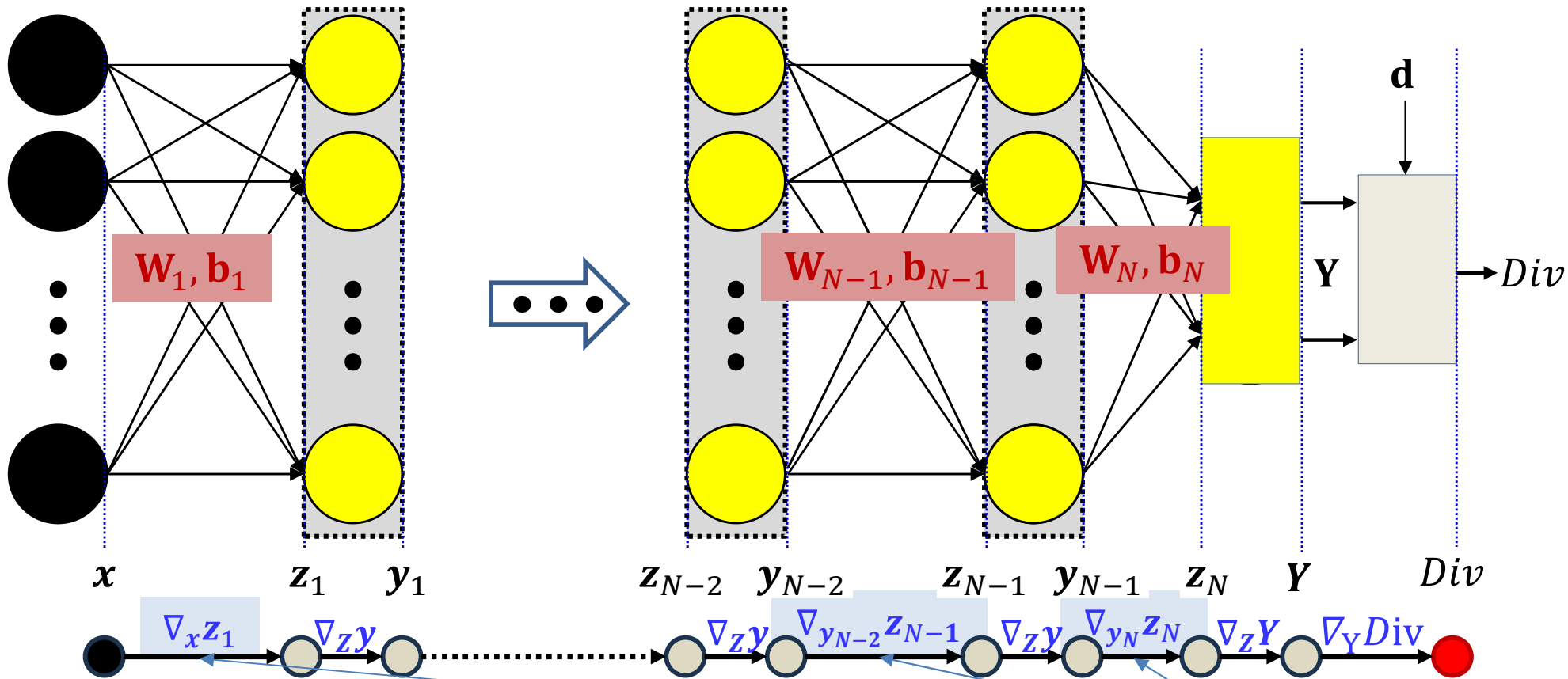

- The network again (with variables shown)...
- With the divergence we will minimize...
- And the entire influence diagram (with derivatives)
 - Variable subscripts not shown in $\nabla_z y$ for brevity

The backward pass

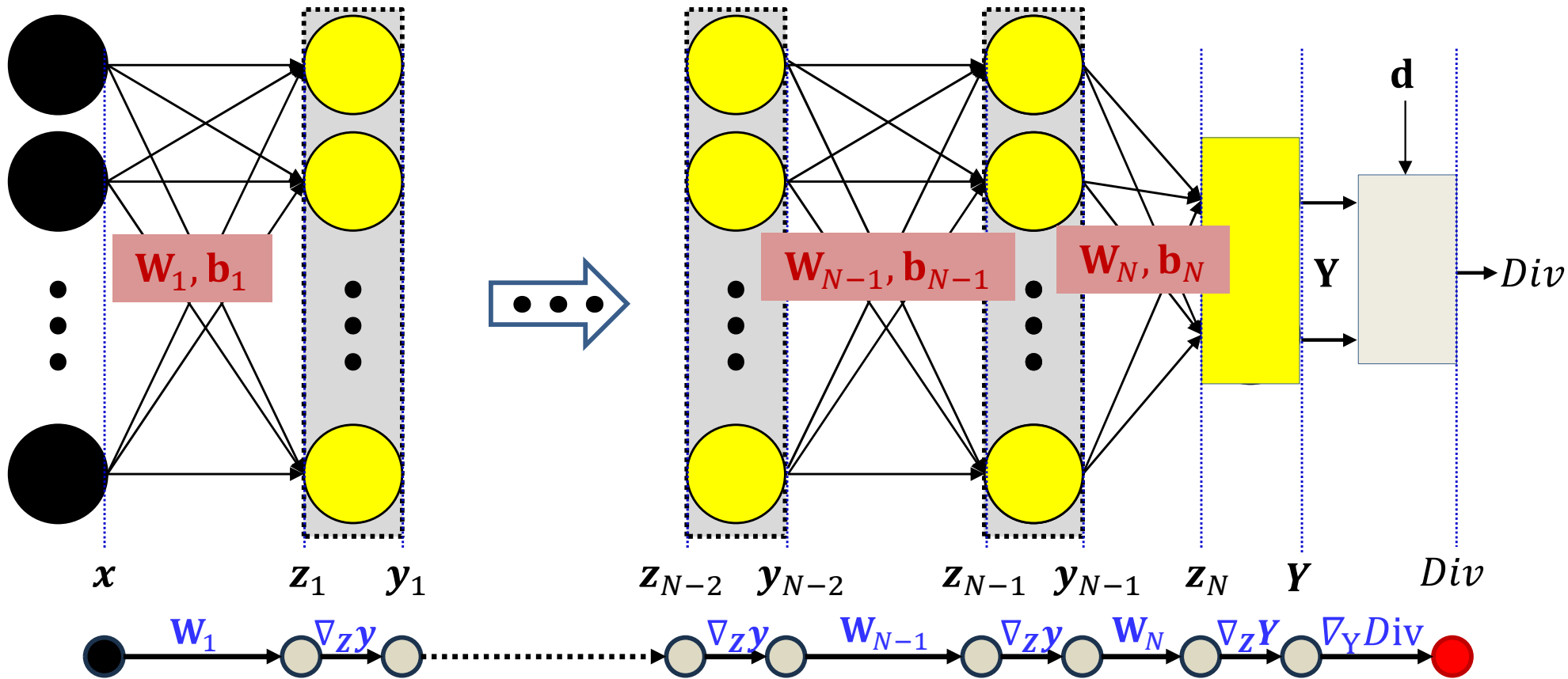

- The network again (with variables shown)...
- With the divergence we will minimize...
- And the entire influence diagram (with derivatives)
 - Variable subscripts not shown in $\nabla_{z^j} y$ for brevity

The backward pass

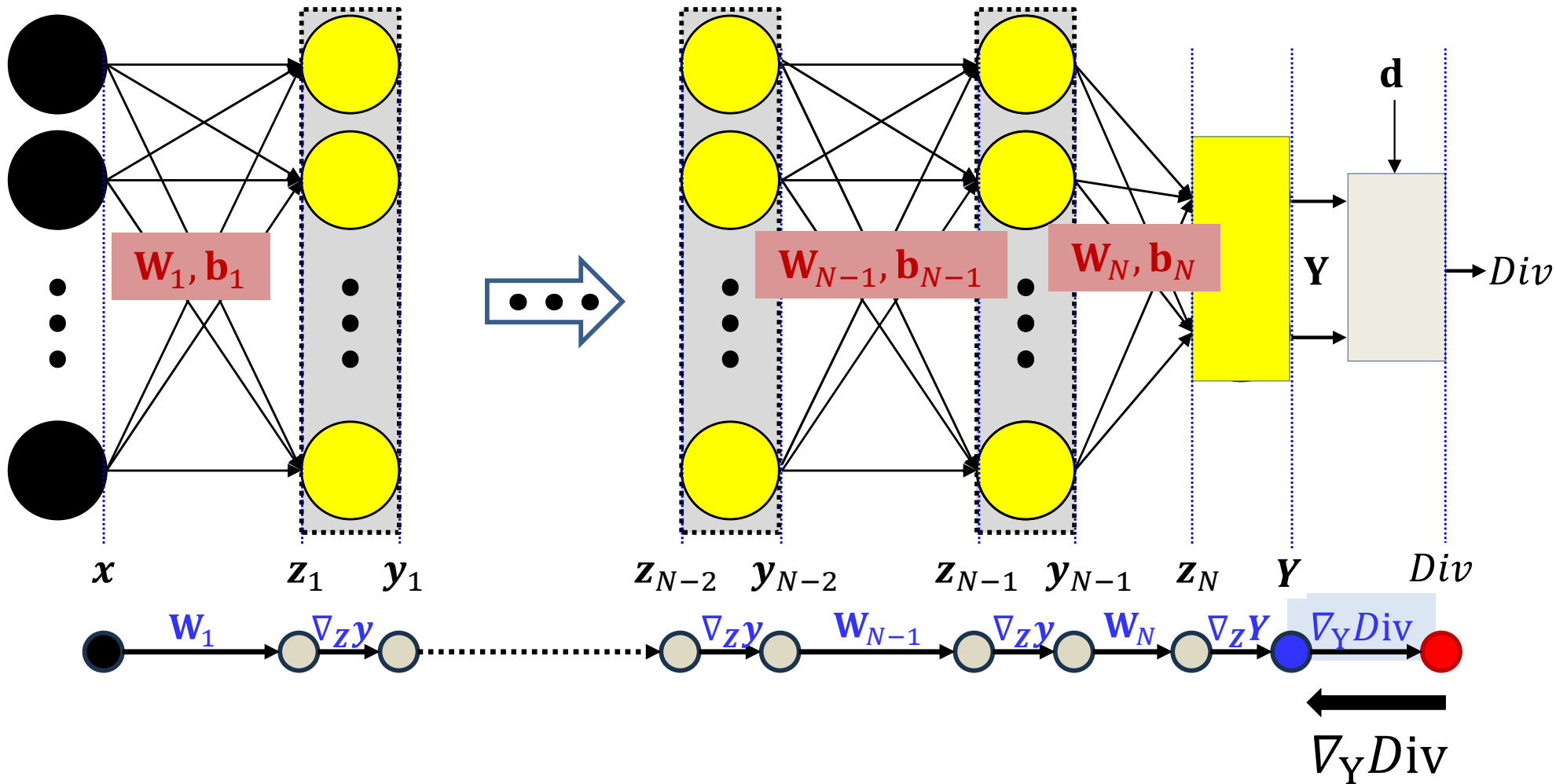

First compute the derivative of the divergence w.r.t. Y .
 The actual derivative depends on the divergence function.

N.B: The gradient is the transpose of the derivative

The backward pass

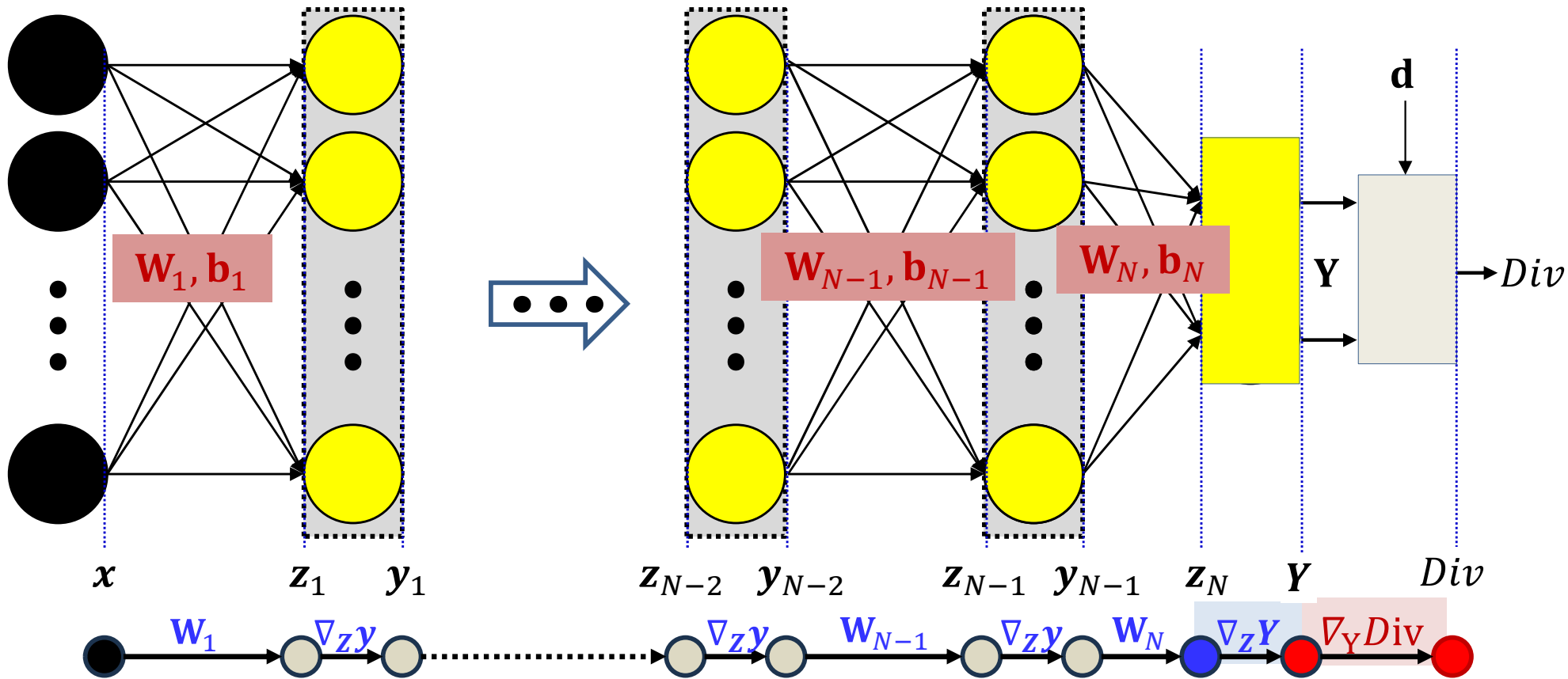

Compute the derivative w.r.t z_N from the derivative at Y using the chain rule

$$\nabla_{z_N} Div = \nabla_Y Div \cdot \nabla_{z_N} Y$$

Already computed New term

The backward pass

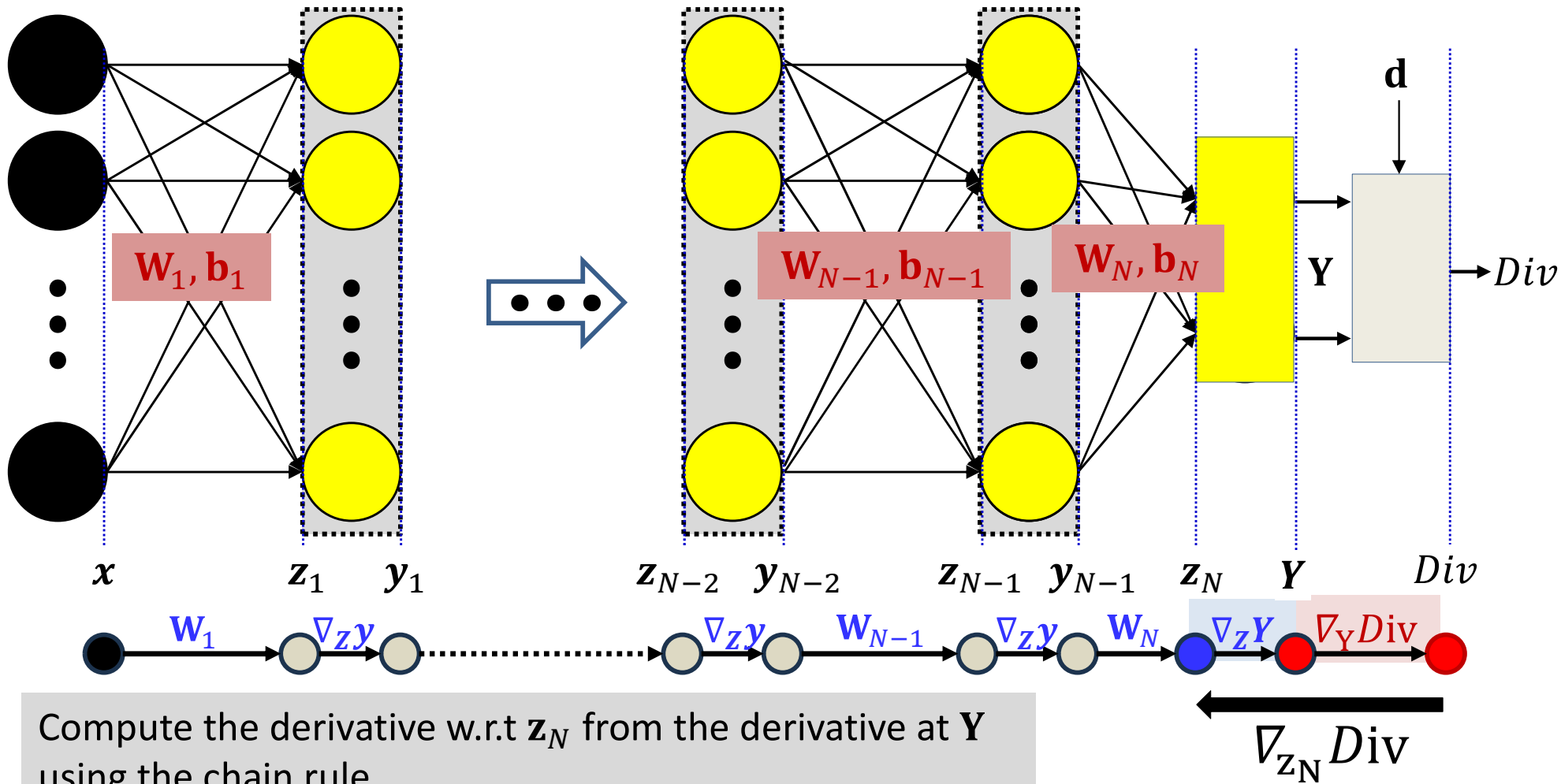

$$\nabla_{z_N} Div = \nabla_Y Div \cdot J_Y(z_N)$$

Already computed Jacobian

$\nabla_{z_N} Y$ is just the Jacobian of the activation function

The backward pass

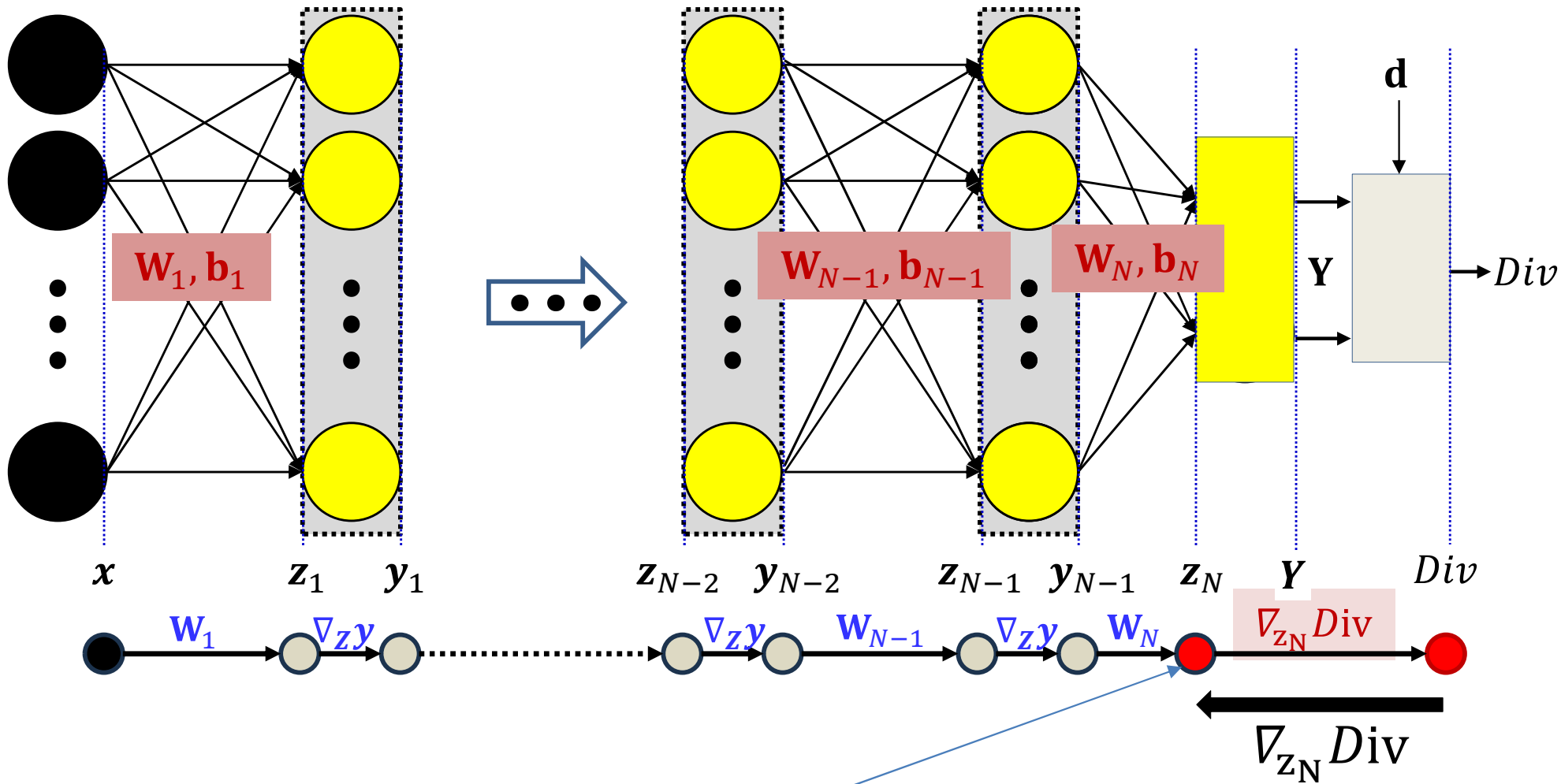

We now have the derivative for z_N

The backward pass

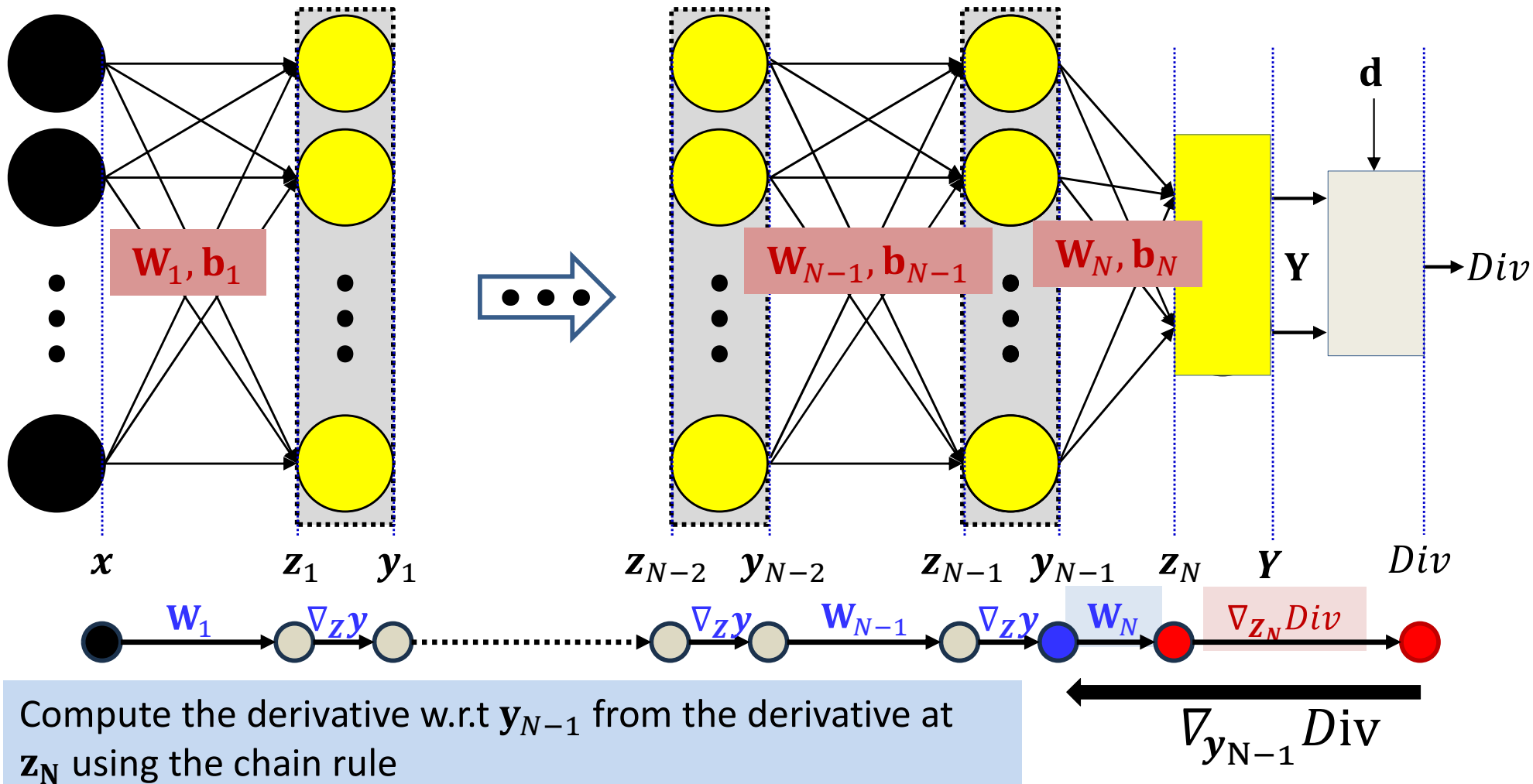

$$\nabla_{y_{N-1}} Div = \nabla_{z_N} Div W_N$$

$$z_N = W_N y_{N-1} + b_N \Rightarrow \nabla_{y_{N-1}} z_N = W_N$$

The backward pass

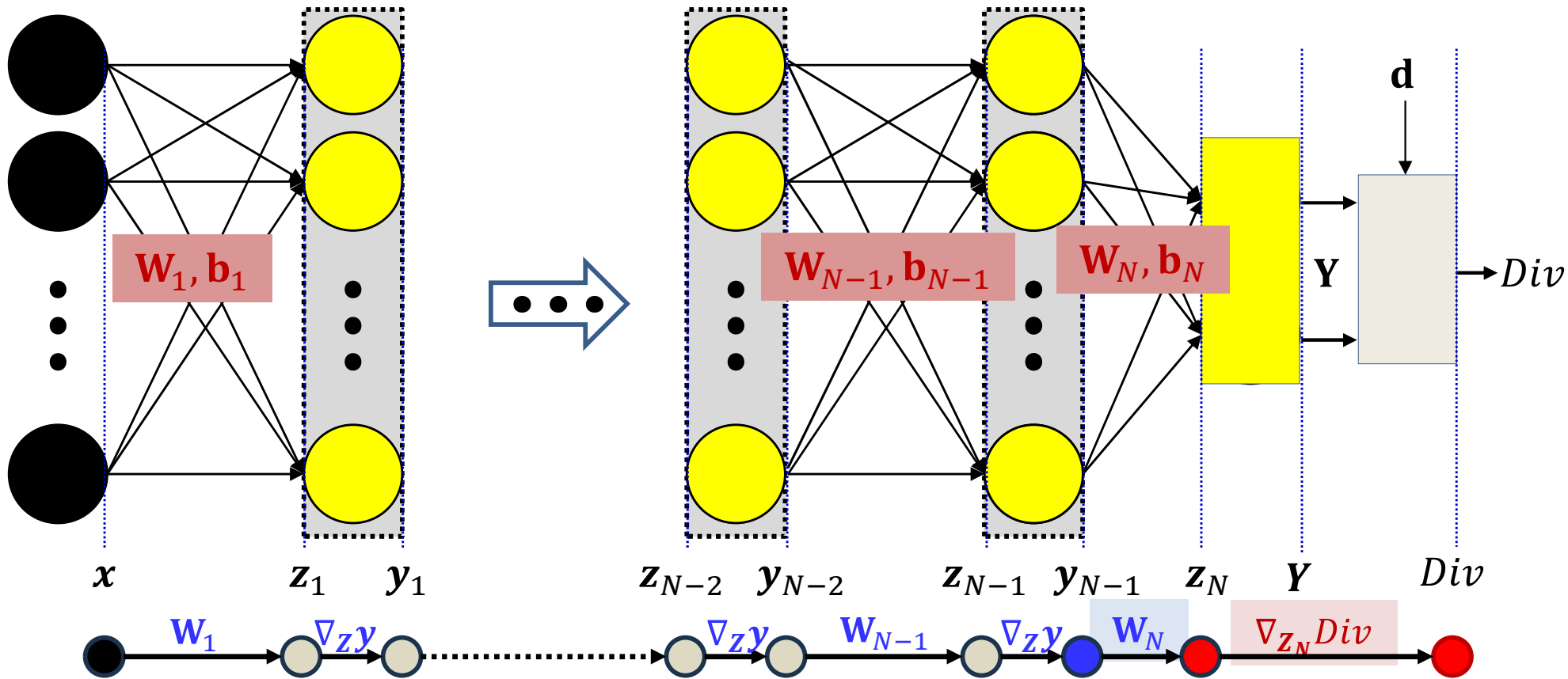

Compute the derivative w.r.t y_{N-1} from the derivative at z_N using the chain rule

$$\nabla_{y_{N-1}} Div = \nabla_{z_N} Div \mathbf{W}_N$$

Already computed New term

$$z_N = \mathbf{W}_N y_{N-1} + \mathbf{b}_N \Rightarrow \nabla_{y_{N-1}} z_N = \mathbf{W}_N$$

The backward pass

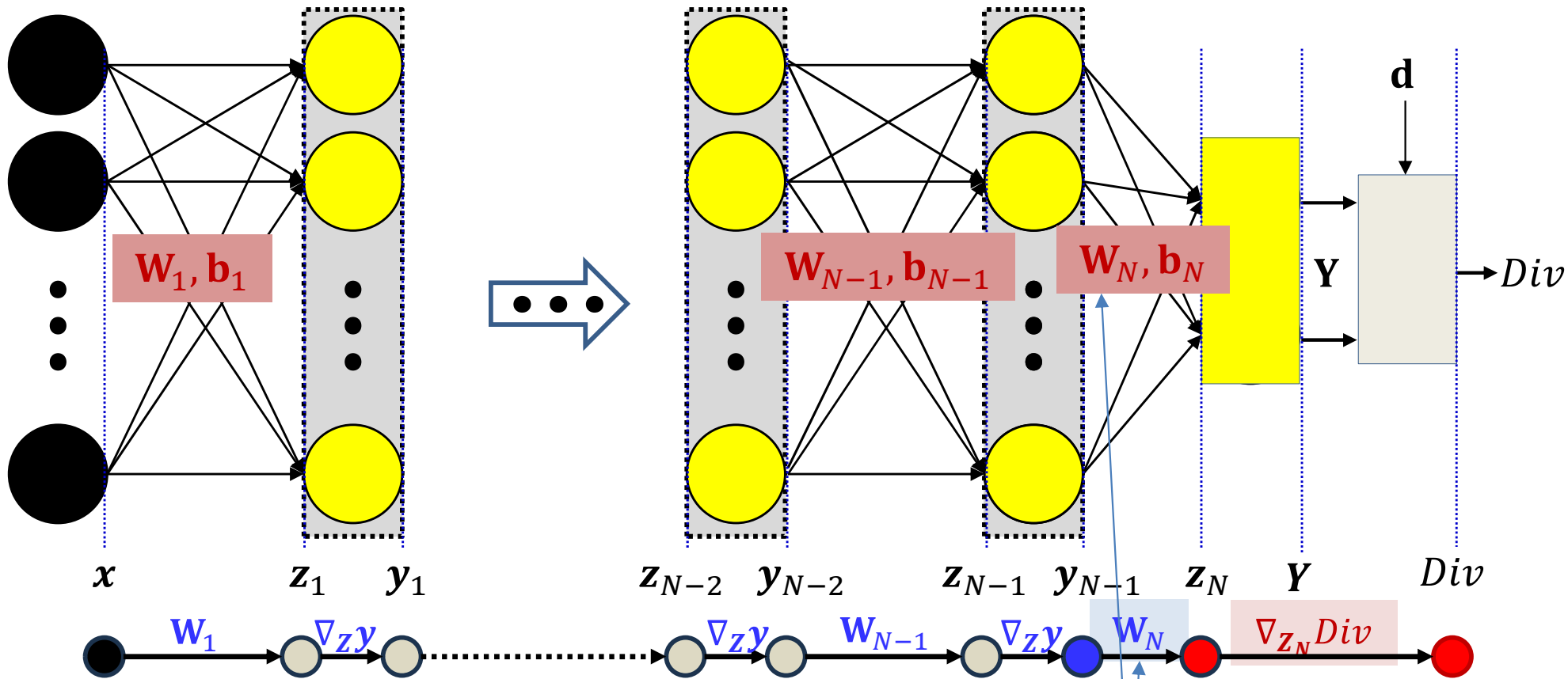

Compute the derivative w.r.t y_{N-1} from the derivative at z_N using the chain rule

$$\nabla_{y_{N-1}} Div = \nabla_{z_N} Div \mathbf{W}_N$$

Already computed ▬ ▬ New term

$$z_N = \mathbf{W}_N y_{N-1} + \mathbf{b}_N \Rightarrow \nabla_{y_{N-1}} z_N = \mathbf{W}_N$$

Must also compute the derivative w.r.t the W_N and b_N using the rule for affine transforms

The backward pass

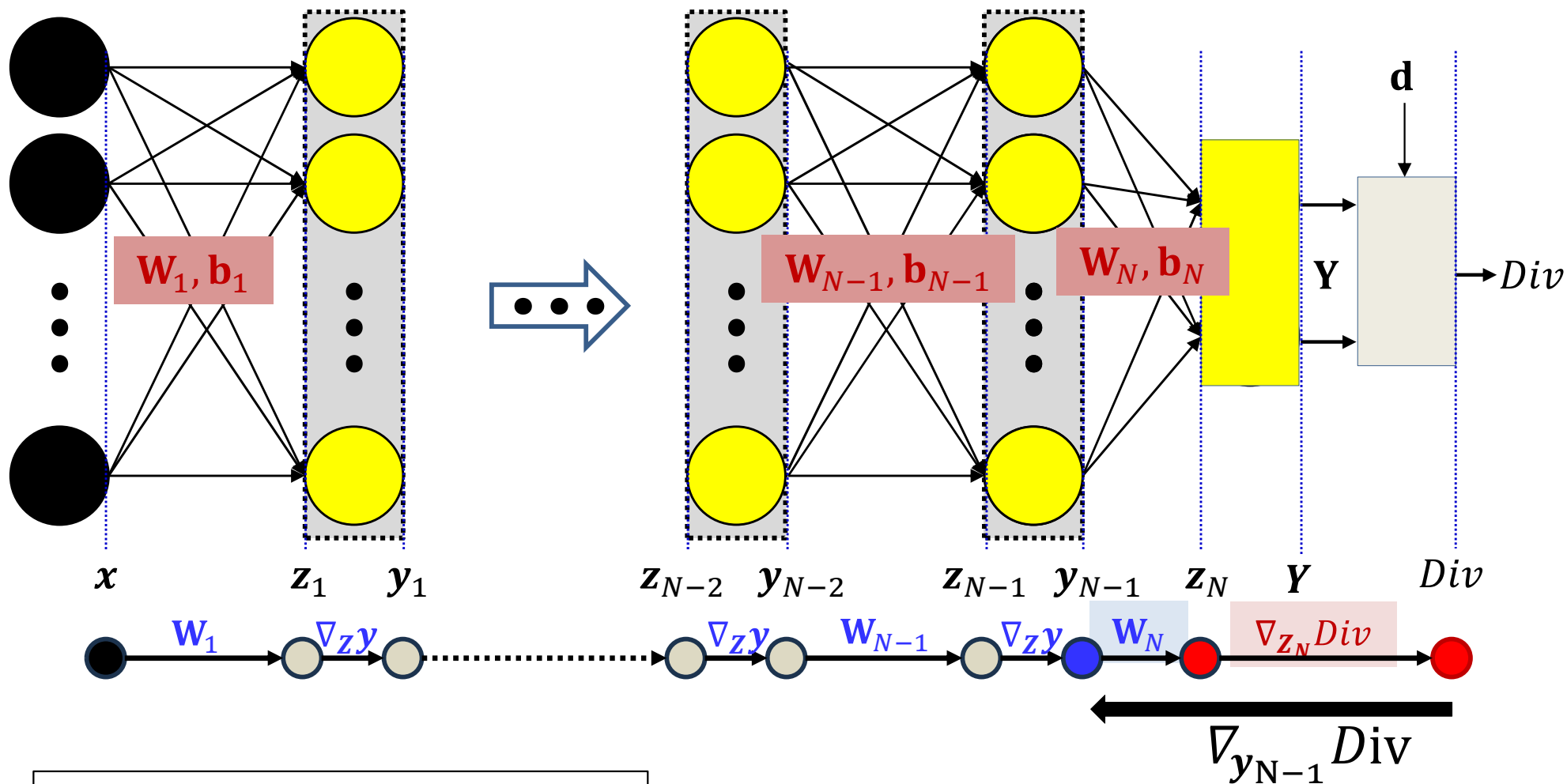

$$\nabla_{y_{N-1}} Div = \nabla_{z_N} Div W_N$$

Affine parameter rules

$z = Wy + b$	$\nabla_b Div = \nabla_z Div$
$Div = Div(z)$	$\nabla_W Div = y \nabla_z Div$

$\nabla_{W_N} Div = y_{N-1} \nabla_{z_N} Div$
$\nabla_{b_N} Div = \nabla_{z_N} Div$

The backward pass

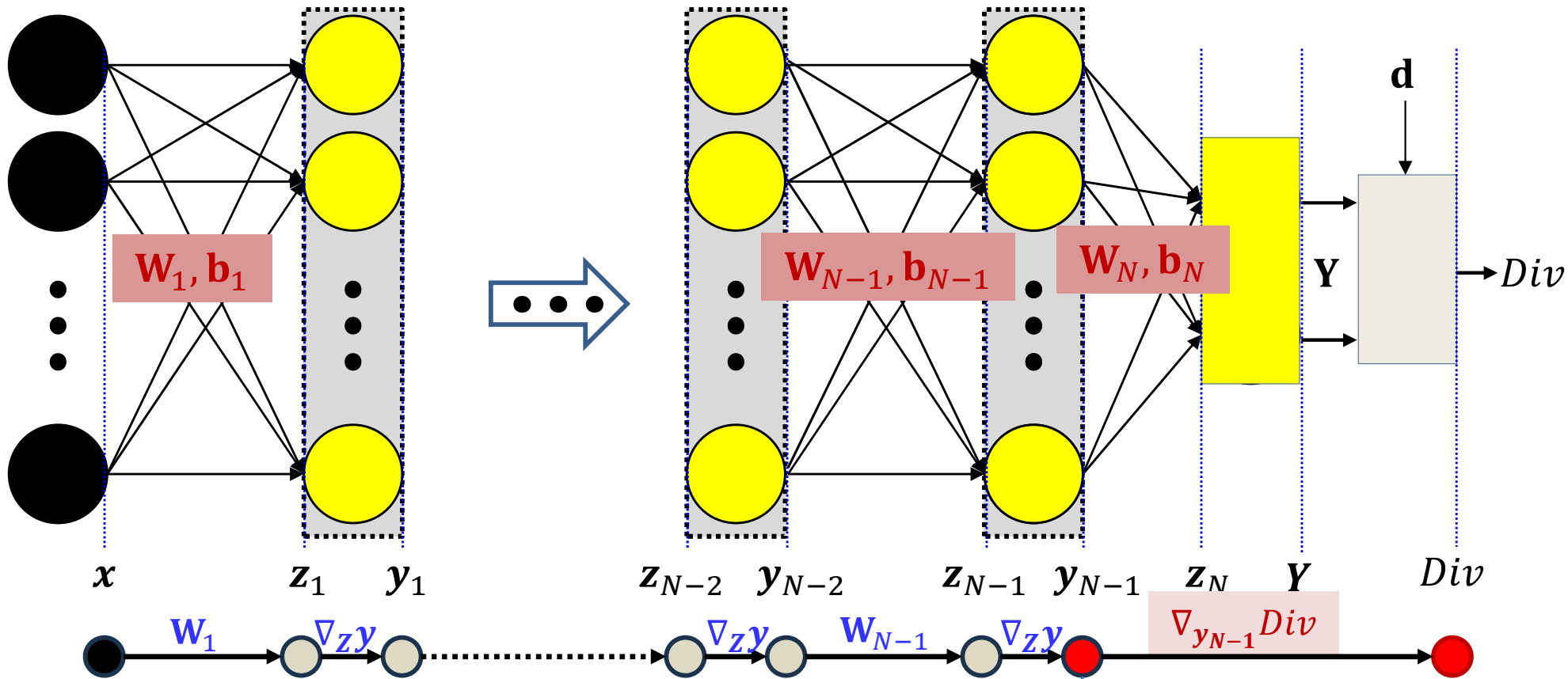

$$\nabla_{y_{N-1}} Div = \nabla_{z_N} Div W_N$$

$$\nabla_{W_N} Div = y_{N-1} \nabla_{z_N} Div$$

$$\nabla_{b_N} Div = \nabla_{z_N} Div$$

We now have the derivative for y_{N-1}

The backward pass

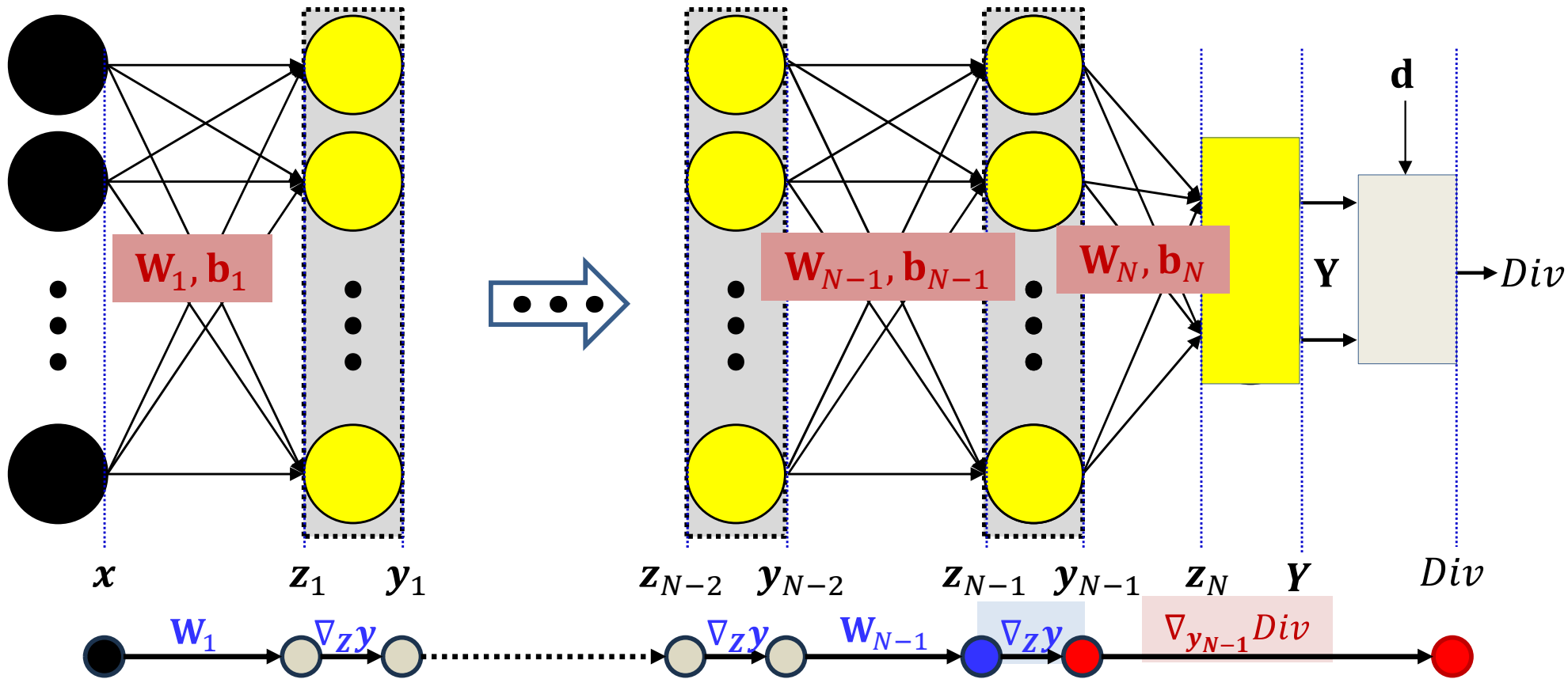

Compute the derivative w.r.t z_{N-1} from the derivative at y_{N-1} using the chain rule

$$\nabla_{z_{N-1}} Div = \nabla_{y_{N-1}} Div \cdot \nabla_{z_{N-1}} y_{N-1}$$

Already computed

New term

The backward pass

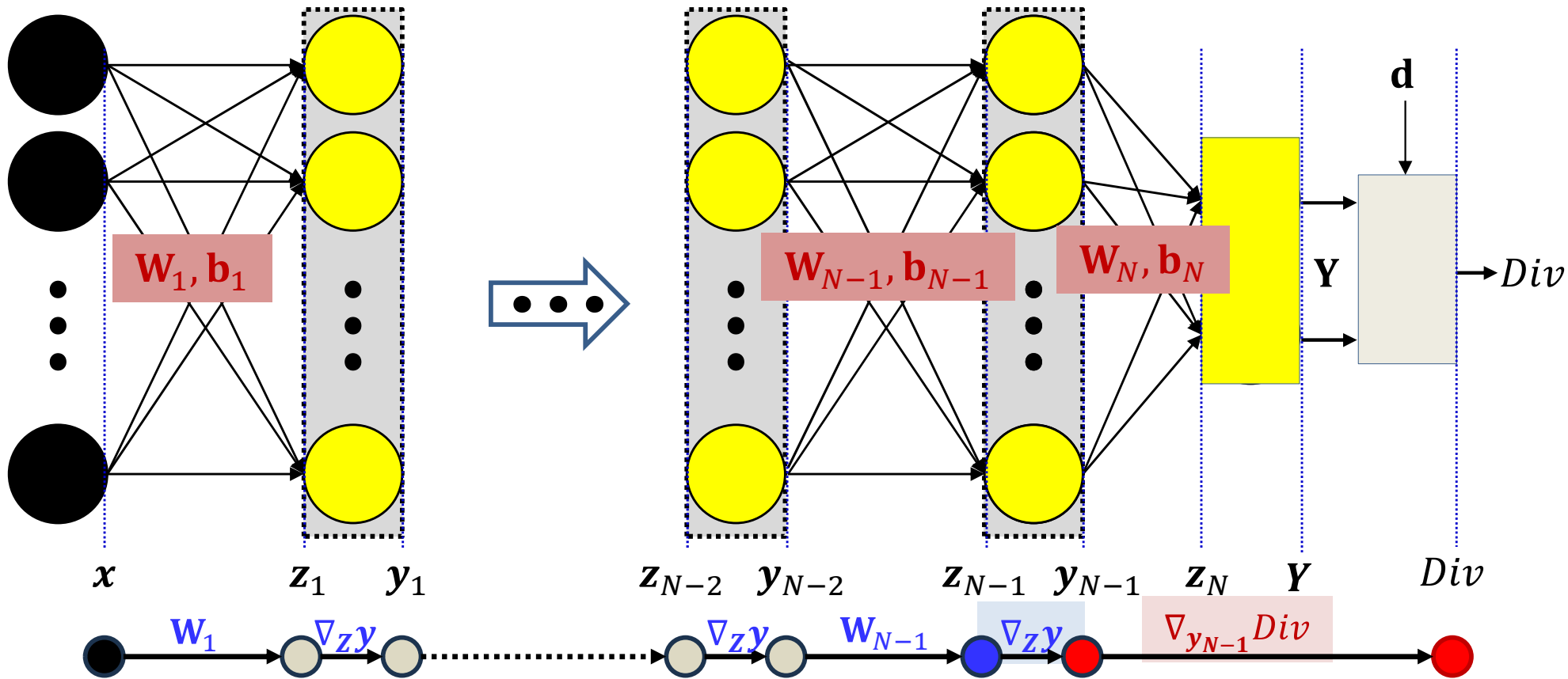

Compute the derivative w.r.t z_{N-1} from the derivative at y_{N-1} using the chain rule

$$\nabla_{z_{N-1}} Div = \nabla_{y_{N-1}} Div \cdot \underbrace{J_{y_{N-1}}(z_{N-1})}_{\text{Jacobian}}$$

Already computed

Jacobian

$\nabla_{z_{N-1}} y_{N-1}$ is the Jacobian of the activation function. It is a diagonal matrix for scalar activations

The backward pass

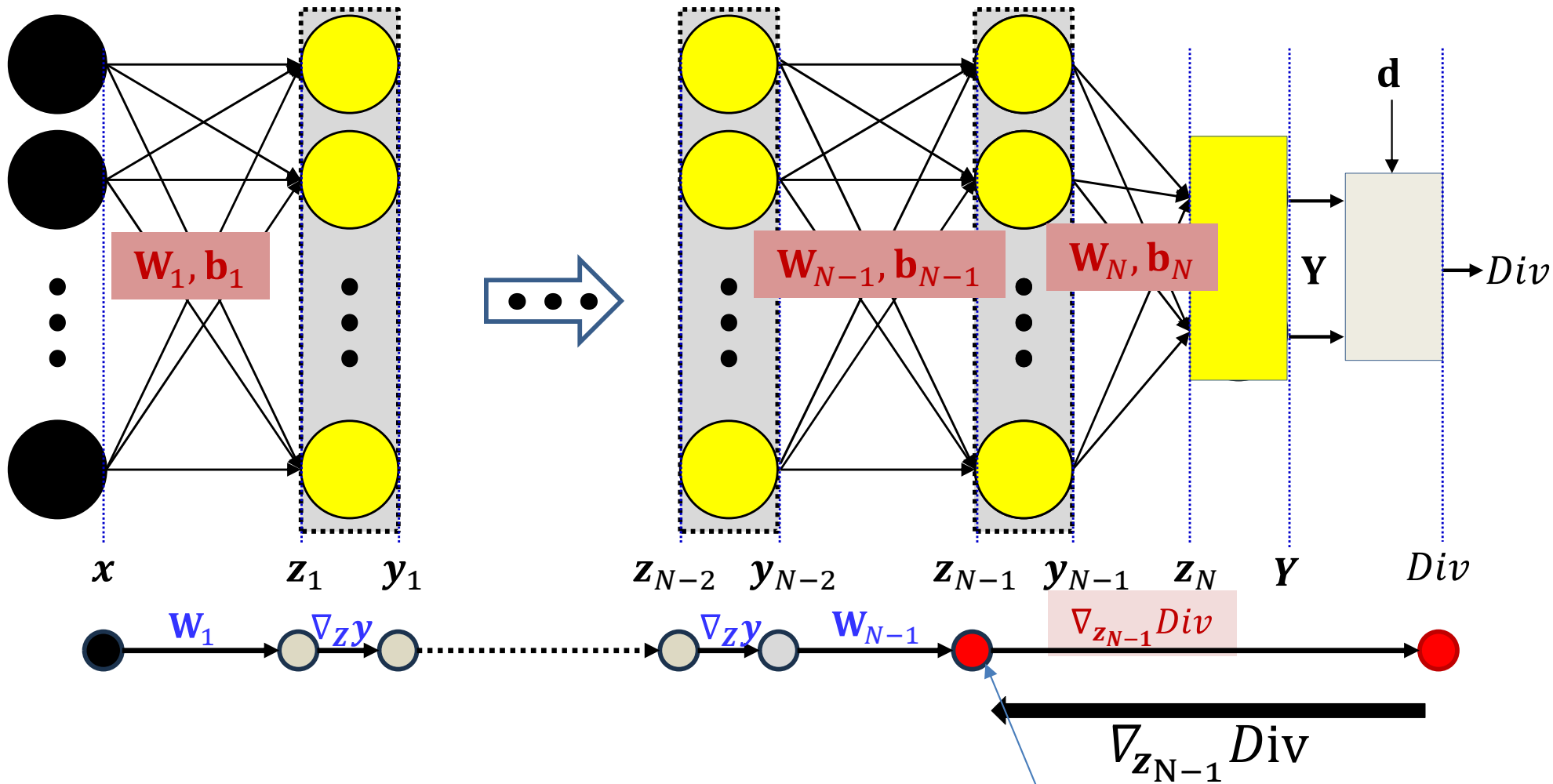

$$\nabla_{z_{N-1}} Div = \nabla_{y_{N-1}} Div \cdot J_{y_{N-1}}(z_{N-1})$$

We now have the derivative for z_{N-1}

The backward pass

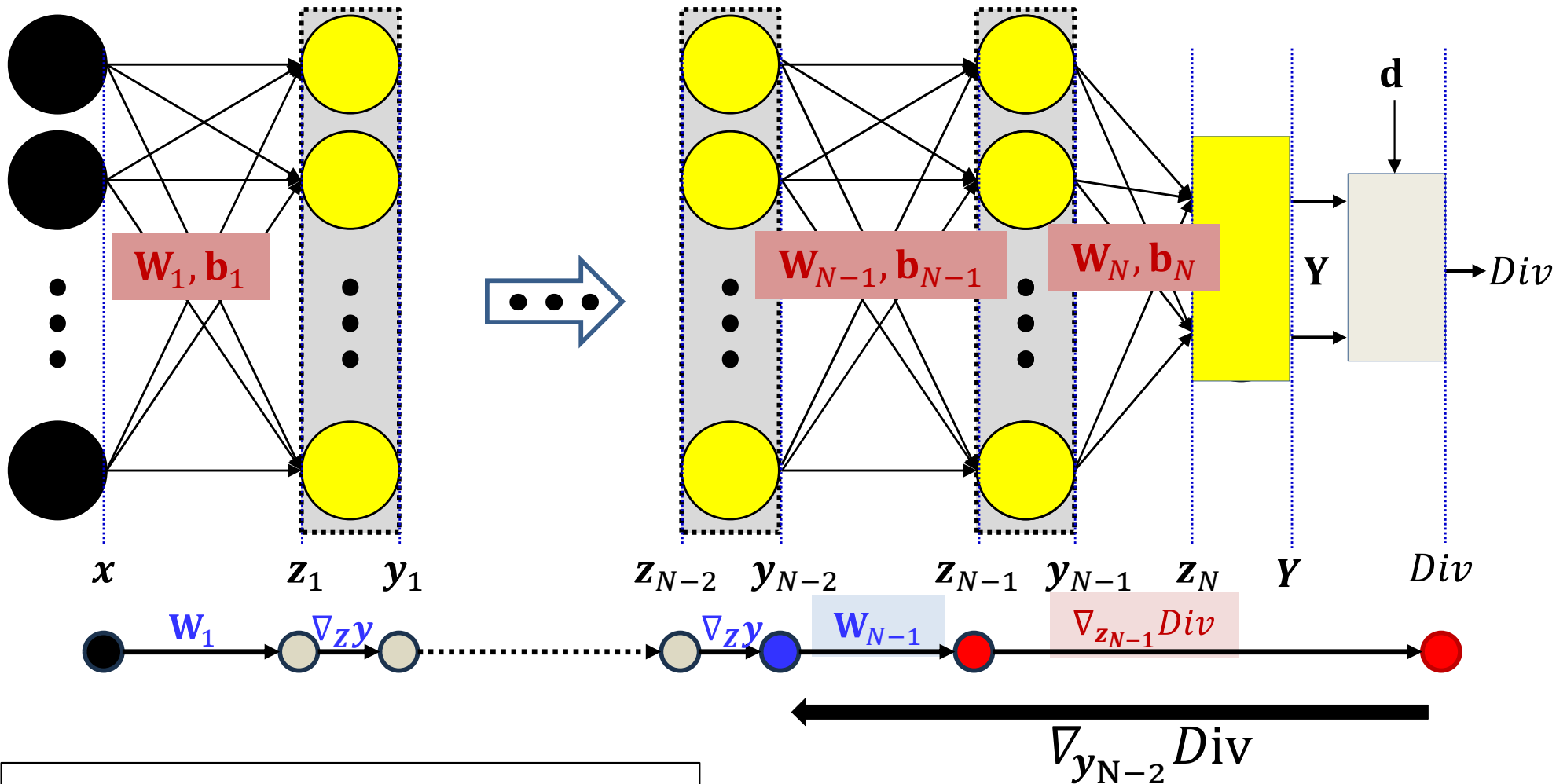

$$\nabla_{y_{N-2}} Div = \nabla_{z_{N-1}} Div \cdot W_{N-1}$$

Already computed New

The backward pass

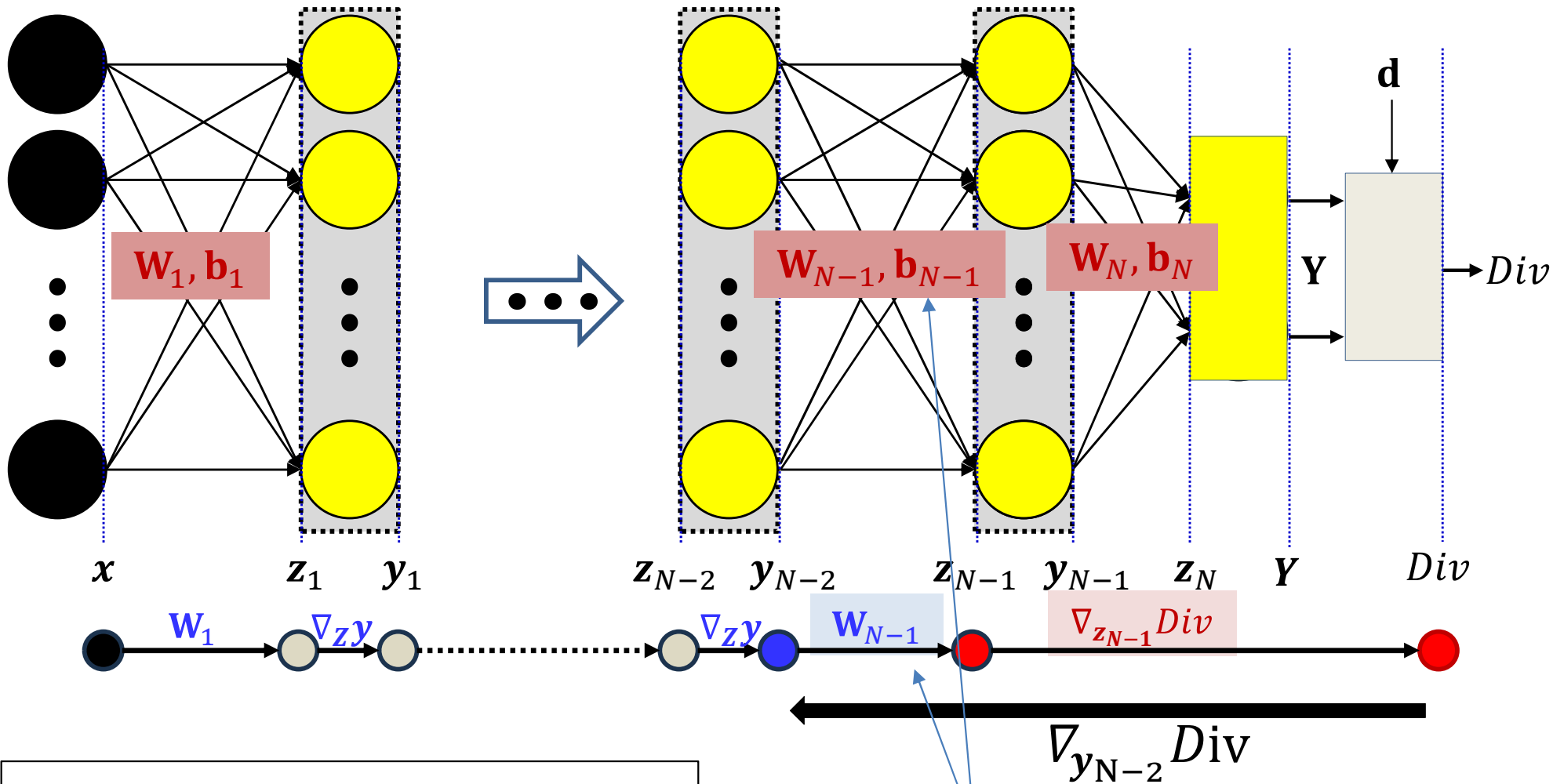

$$\nabla_{y_{N-2}} Div = \nabla_{z_{N-1}} Div \cdot \mathbf{W}_{N-1}$$

Already computed New

$$\nabla_{\mathbf{W}_{N-1}} Div = y_{N-2} \nabla_{z_{N-1}} Div$$

$$\nabla_{\mathbf{b}_{N-1}} Div = \nabla_{z_{N-1}} Div$$

The backward pass

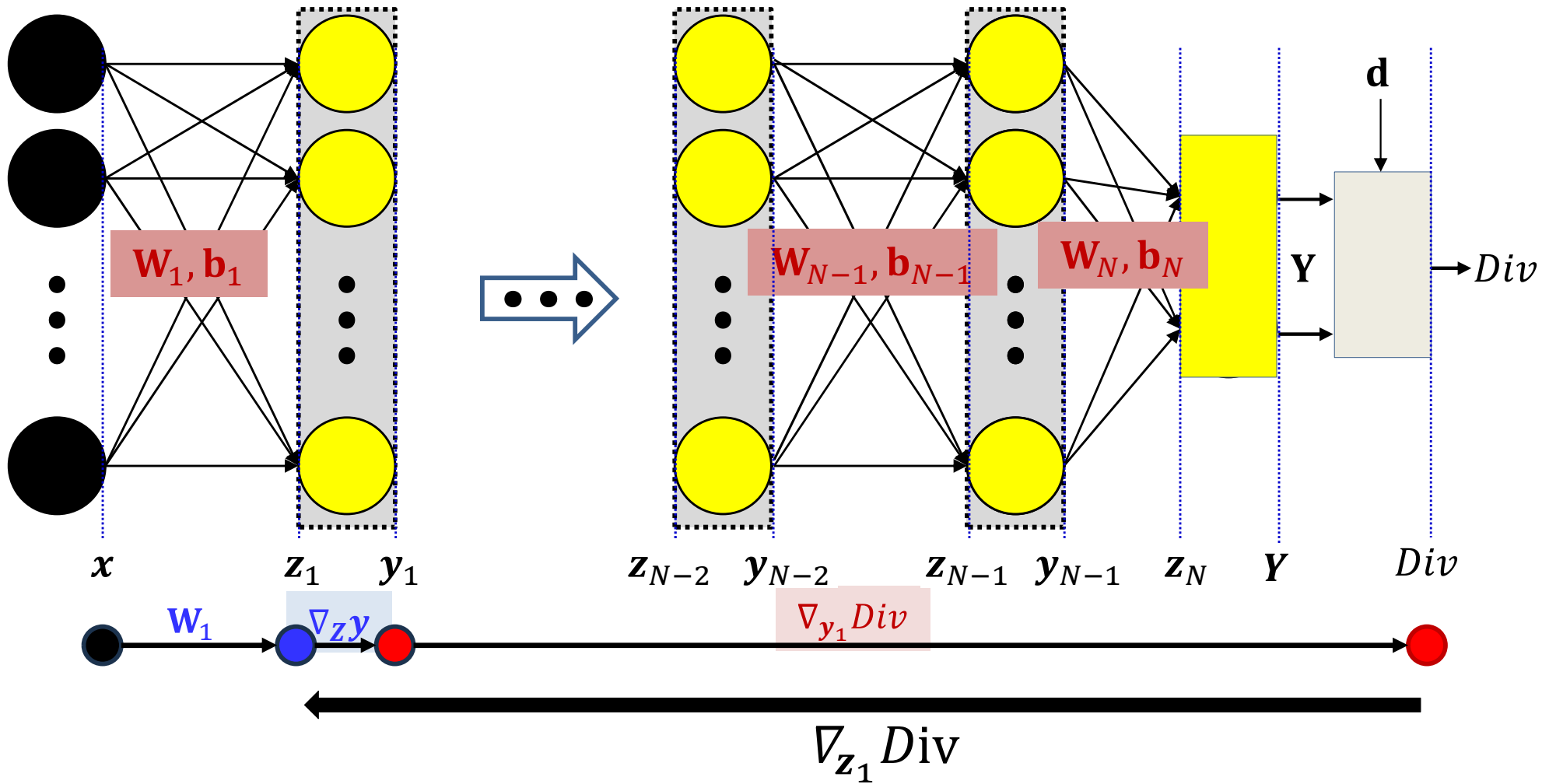

$$\nabla_{z_1} Div = \nabla_{y_1} Div J_{y_1}(z_1)$$

The backward pass

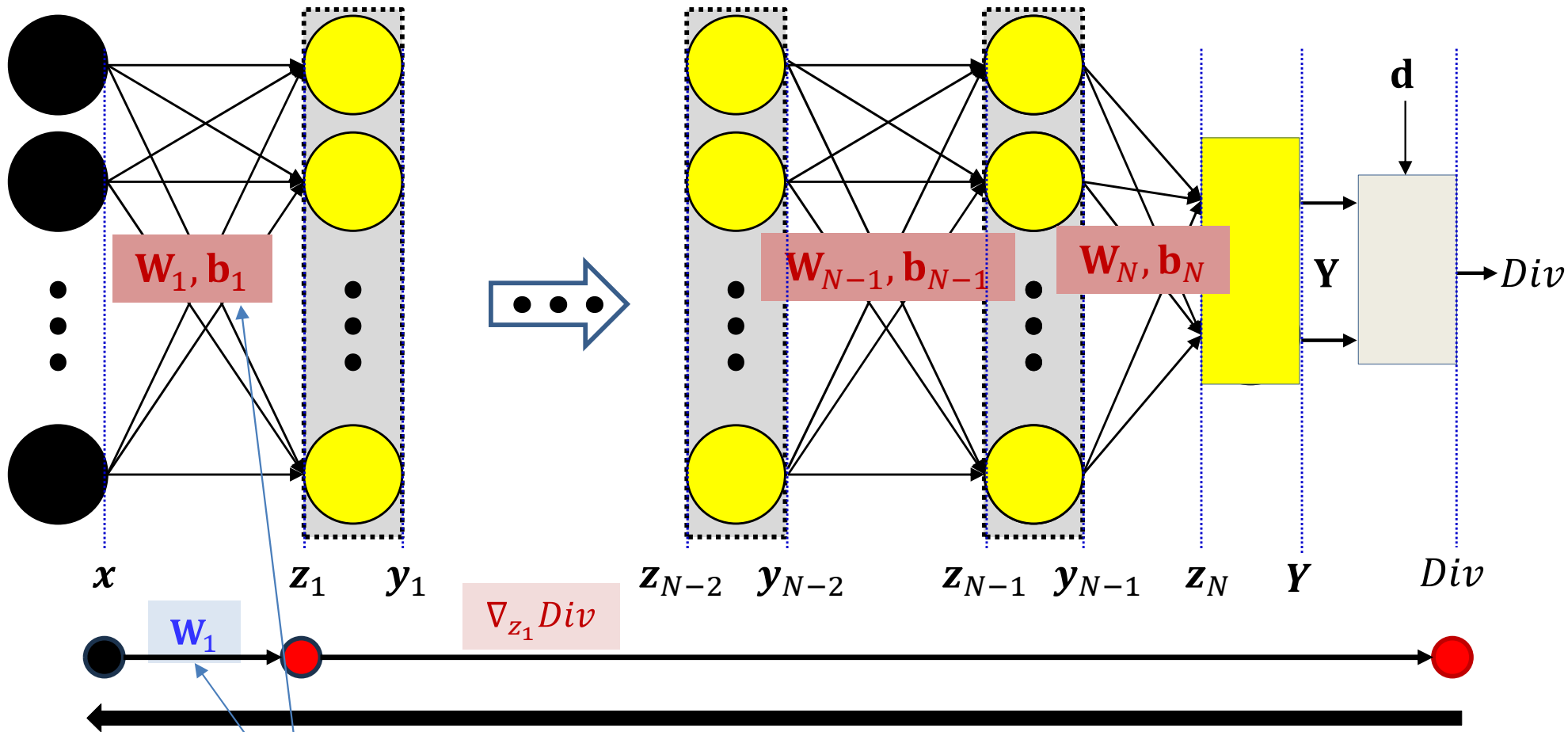

$$\nabla_{W_1} Div = x \nabla_{z_1} Div$$

$$\nabla_{b_1} Div = \nabla_{z_1} Div$$

In some problems we will also want to compute the derivative w.r.t. the input

The backward pass

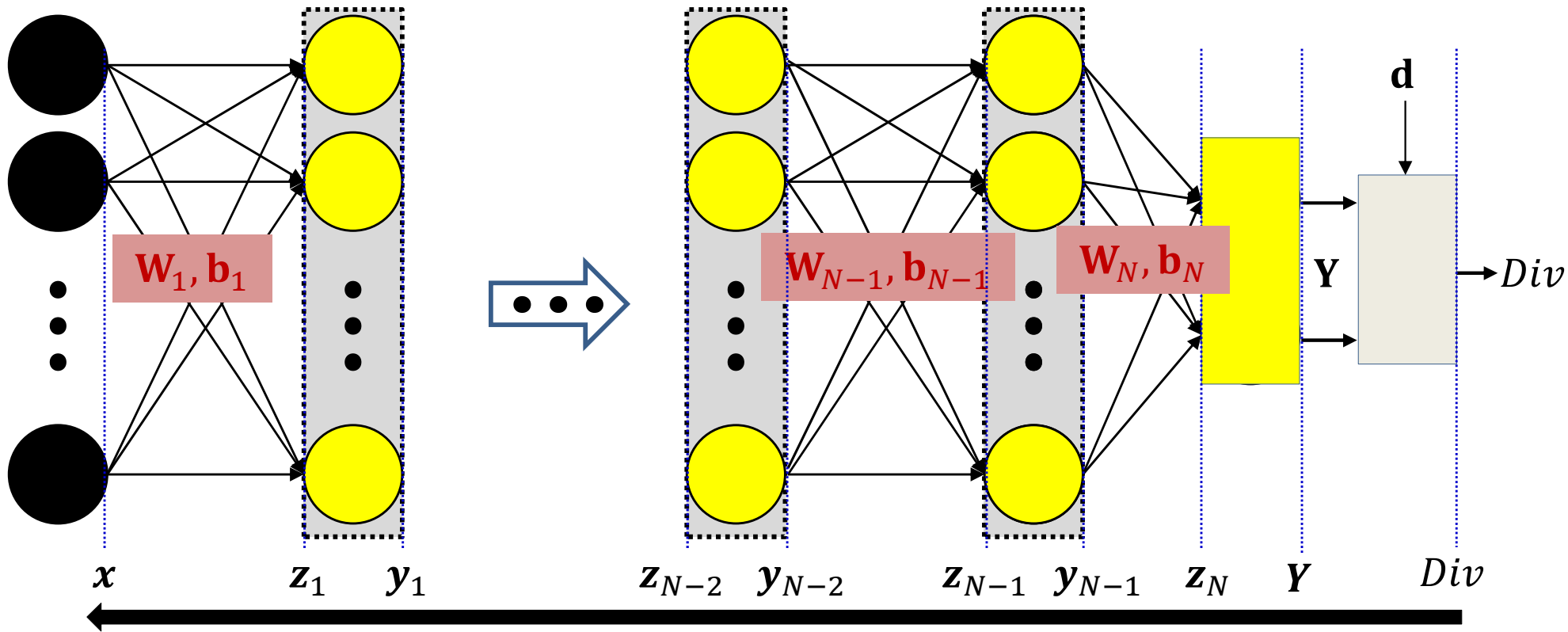

Initialize:

$$\nabla_{y_N} Div = \nabla_Y Div$$

For $k = N$ downto 1:

$$\nabla_{z_k} Div = \nabla_{y_k} Div J_{y_k}(z_k)$$

$$\nabla_{b_k} Div = \nabla_{z_k} Div$$

$$\nabla_{y_{k-1}} Div = \nabla_{z_k} Div W_k$$

$$\nabla_{W_k} Div = y_{k-1} \nabla_{z_k} Div$$

The Backward Pass

- Set $\mathbf{y}_N = Y, \mathbf{y}_0 = \mathbf{x}$
- Initialize: Compute $\nabla_{\mathbf{y}_N} Div = \nabla_Y Div$
- For layer $k = N$ downto 1:
 - Compute $J_{\mathbf{y}_k}(\mathbf{z}_k)$
 - Will require intermediate values computed in the forward pass
 - Backward recursion step:

$$\nabla_{\mathbf{z}_k} Div = \nabla_{\mathbf{y}_k} Div J_{\mathbf{y}_k}(\mathbf{z}_k)$$

$$\nabla_{\mathbf{y}_{k-1}} Div = \nabla_{\mathbf{z}_k} Div \mathbf{W}_k$$

- Gradient computation:

$$\nabla_{\mathbf{W}_k} Div = \mathbf{y}_{k-1} \nabla_{\mathbf{z}_k} Div$$

$$\nabla_{\mathbf{b}_k} Div = \nabla_{\mathbf{z}_k} Div$$

The Backward Pass

- Set $\mathbf{y}_N = Y, \mathbf{y}_0 = \mathbf{x}$
- Initialize: Compute $\nabla_{\mathbf{y}_N} Div = \nabla_Y Div$
- For layer $k = N$ downto 1:
 - Compute $J_{\mathbf{y}_k}(\mathbf{z}_k)$
 - Will require intermediate values computed in the forward pass
 - Backward recursion step: Note analogy to forward pass
$$\nabla_{\mathbf{z}_k} Div = \nabla_{\mathbf{y}_k} Div J_{\mathbf{y}_k}(\mathbf{z}_k)$$
$$\nabla_{\mathbf{y}_{k-1}} Div = \nabla_{\mathbf{z}_k} Div \mathbf{W}_k$$
 - Gradient computation:

$$\nabla_{\mathbf{W}_k} Div = \mathbf{y}_{k-1} \nabla_{\mathbf{z}_k} Div$$
$$\nabla_{\mathbf{b}_k} Div = \nabla_{\mathbf{z}_k} Div$$

For comparison: The Forward Pass

- Set $\mathbf{y}_0 = \mathbf{x}$
- For layer $k = 1$ to N :
 - Forward recursion step:

$$\mathbf{z}_k = \mathbf{W}_k \mathbf{y}_{k-1} + \mathbf{b}_k$$
$$\mathbf{y}_k = \mathbf{f}_k(\mathbf{z}_k)$$

- Output:

$$\mathbf{Y} = \mathbf{y}_N$$

Neural network training algorithm

- Initialize all weights and biases $(\mathbf{W}_1, \mathbf{b}_1, \mathbf{W}_2, \mathbf{b}_2, \dots, \mathbf{W}_N, \mathbf{b}_N)$

- Do:

- $Loss = 0$

- For all k , initialize $\nabla_{\mathbf{W}_k} Loss = 0, \nabla_{\mathbf{b}_k} Loss = 0$

- For all $t = 1:T$ # Loop through training instances

- Forward pass : Compute

- Output $\mathbf{Y}(\mathbf{X}_t)$

- Divergence $Div(\mathbf{Y}_t, \mathbf{d}_t)$

- $Loss += Div(\mathbf{Y}_t, \mathbf{d}_t)$

- Backward pass: For all k compute:

- $\nabla_{\mathbf{y}_k} Div = \nabla_{\mathbf{z}_{k+1}} Div \mathbf{W}_{k+1}$

- $\nabla_{\mathbf{z}_k} Div = \nabla_{\mathbf{y}_k} Div J_{\mathbf{y}_k}(\mathbf{z}_k)$

- $\nabla_{\mathbf{W}_k} Div(\mathbf{Y}_t, \mathbf{d}_t) = \mathbf{y}_{k-1} \nabla_{\mathbf{z}_k} Div; \nabla_{\mathbf{b}_k} Div(\mathbf{Y}_t, \mathbf{d}_t) = \nabla_{\mathbf{z}_k} Div$

- $\nabla_{\mathbf{W}_k} Loss += \nabla_{\mathbf{W}_k} Div(\mathbf{Y}_t, \mathbf{d}_t); \nabla_{\mathbf{b}_k} Loss += \nabla_{\mathbf{b}_k} Div(\mathbf{Y}_t, \mathbf{d}_t)$

- For all k , update:

$$\mathbf{W}_k = \mathbf{W}_k - \frac{\eta}{T} (\nabla_{\mathbf{W}_k} Loss)^T; \quad \mathbf{b}_k = \mathbf{b}_k - \frac{\eta}{T} (\nabla_{\mathbf{b}_k} Loss)^T$$

- Until $Loss$ has converged

Setting up for digit recognition

Training data

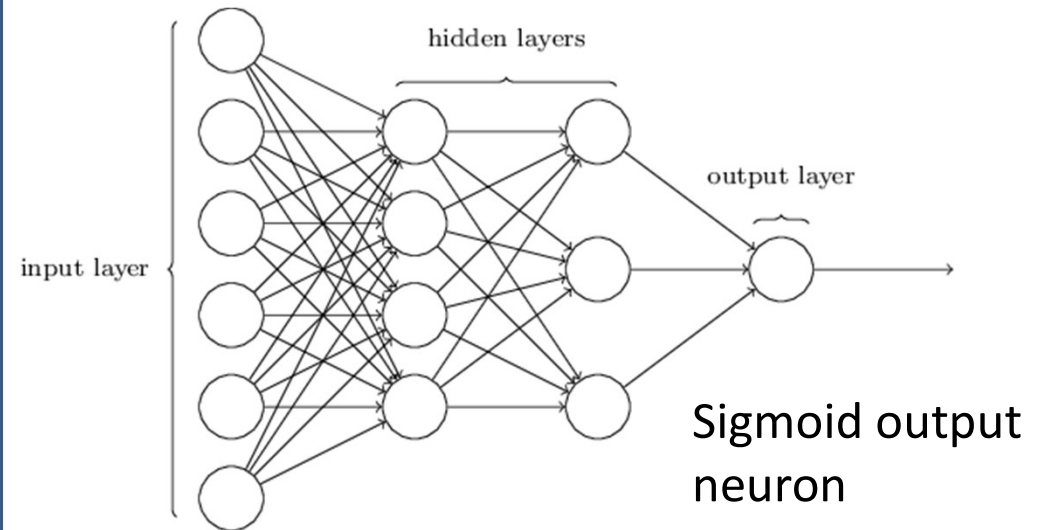
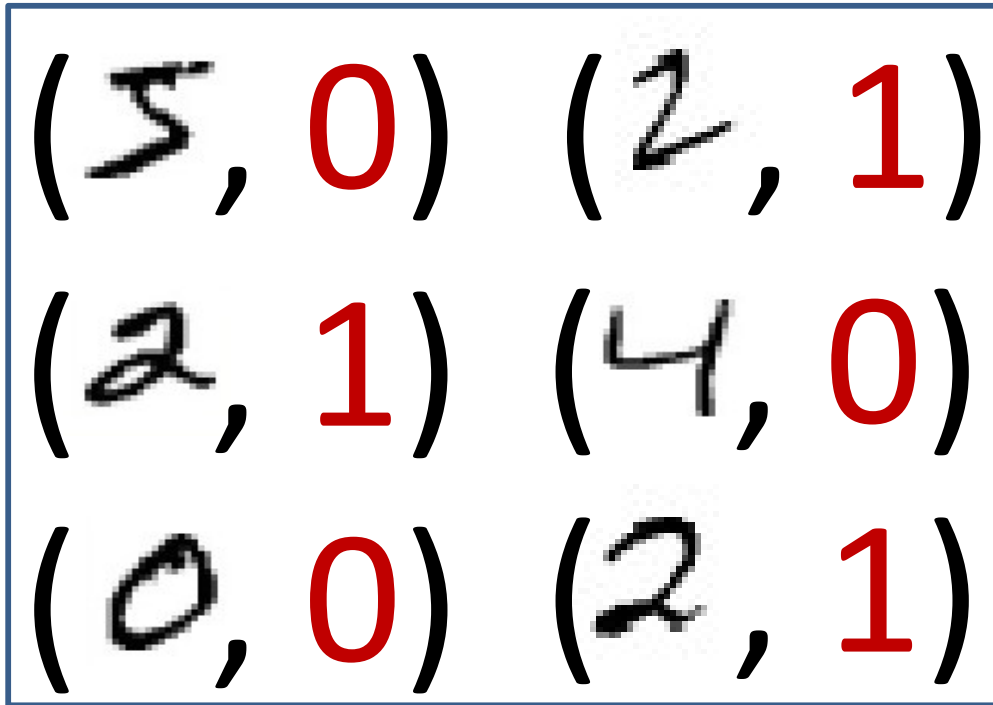

- Simple Problem: Recognizing “2” or “not 2”
- Single output with sigmoid activation
 - $Y \in (0,1)$
 - d is either 0 or 1
- Use KL divergence
- Backpropagation to compute derivatives
 - To apply in gradient descent to learn network parameters

Recognizing the digit

Training data

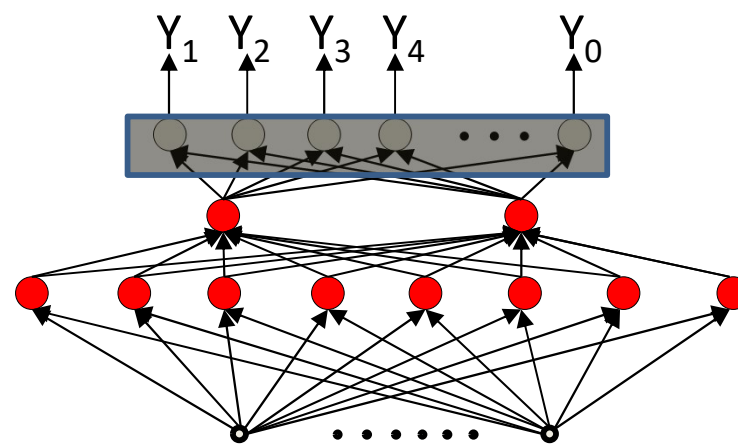
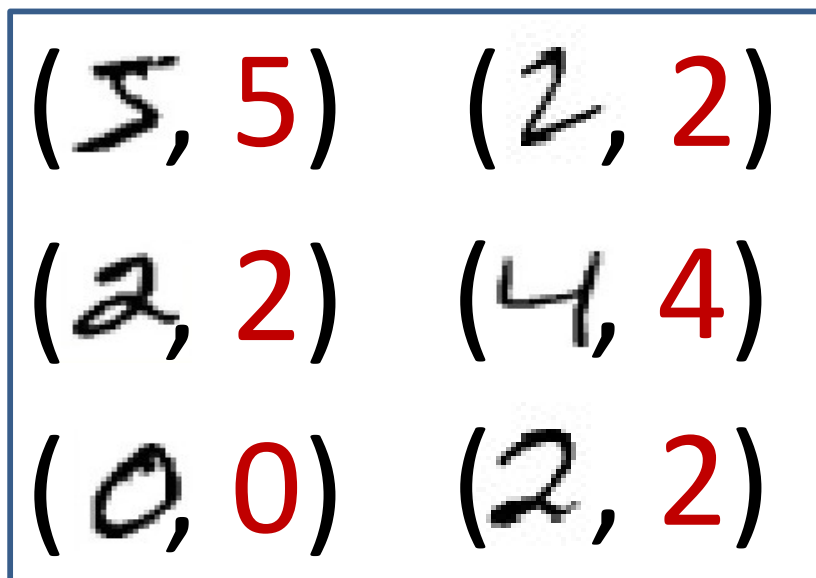

- More complex problem: Recognizing digit
- Network with 10 (or 11) outputs
 - First ten outputs correspond to the ten digits
 - Optional 11th is for none of the above
- Softmax output layer:
 - Ideal output: One of the outputs goes to 1, the others go to 0
- Backpropagation with KL divergence
 - To compute derivatives for gradient descent updates to learn network

Story so far

- Neural networks must be trained to minimize the average divergence between the output of the network and the desired output over a set of training instances, with respect to network parameters.
- Minimization is performed using gradient descent
- Gradients (derivatives) of the divergence (for any individual instance) w.r.t. network parameters can be computed using backpropagation
 - Which requires a “forward” pass of inference followed by a “backward” pass of gradient computation
- The computed gradients can be incorporated into gradient descent

Issues

- Convergence: How well does it learn
 - And how can we improve it
- How well will it generalize (outside training data)
- What does the output really mean?
- *Etc..*

Next up

- Convergence and generalization