

Neural Networks

Learning the network: Part 1

11-785, Spring 2020

Lecture 3

Topics for the day

- The problem of learning
- The perceptron rule for perceptrons
 - And its inapplicability to multi-layer perceptrons
- Greedy solutions for classification networks:
ADALINE and MADALINE
- Learning through Empirical Risk Minimization
- Intro to function optimization and gradient descent

Recap

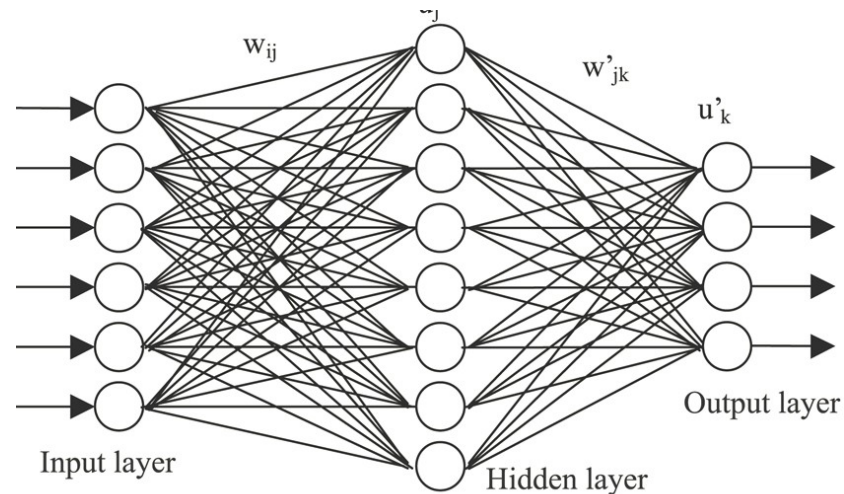

- **Neural networks are universal function approximators**
 - Can model any Boolean function
 - Can model any classification boundary
 - Can model any continuous valued function
- *Provided the network satisfies minimal architecture constraints*
 - Networks with fewer than the required number of parameters can be very poor approximators

These boxes are functions

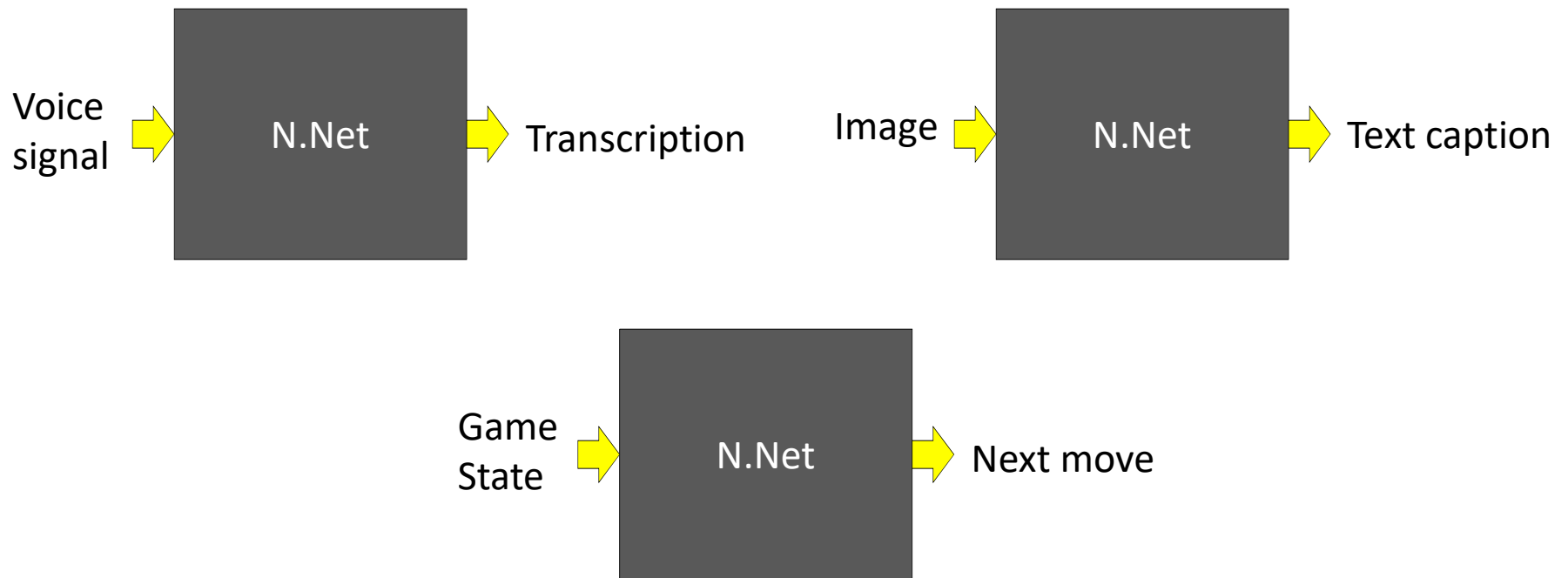

- Take an input
- Produce an output
- Can be modeled by a neural network!

Questions



- Preliminaries:
 - How do we represent the input?
 - How do we represent the output?
- How do we compose the network that performs the requisite function?

Questions

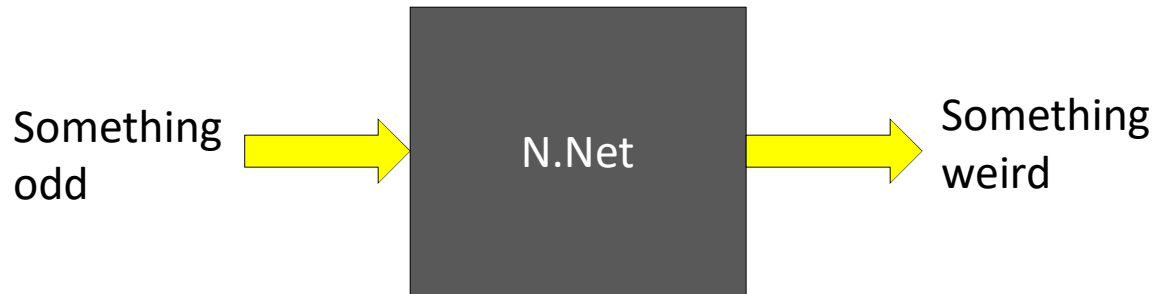

- Preliminaries:

- How do we represent the input?
- How do we represent the output?

A bit later in the program

- *How do we compose the network that performs the requisite function?* ←

The original perceptron

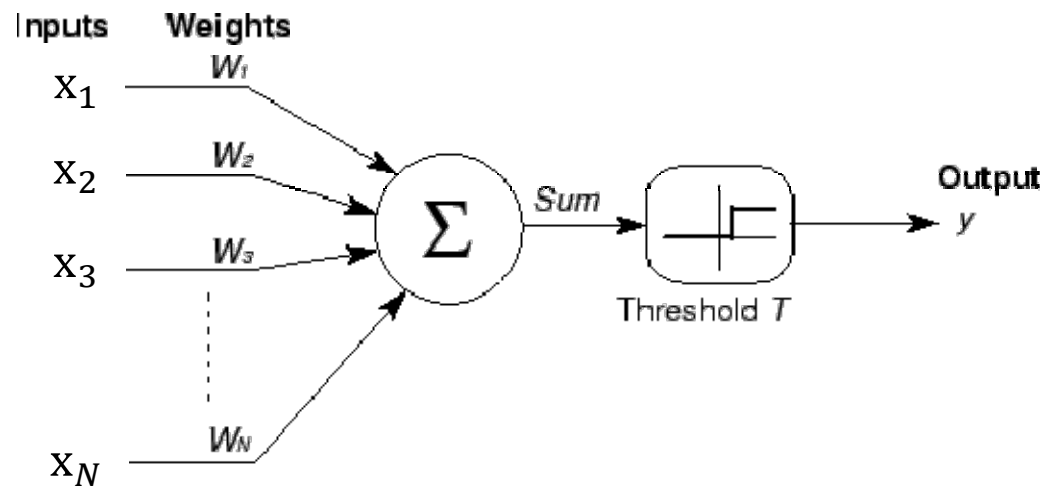

- Simple threshold unit
 - Unit comprises a set of weights and a threshold

Preliminaries: The units in the network

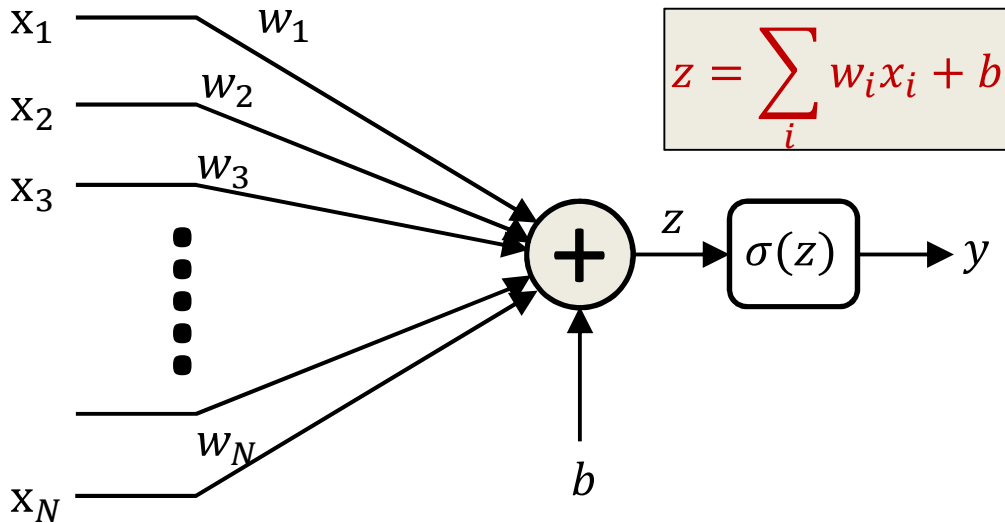

$$z = \sum_i w_i x_i + b$$

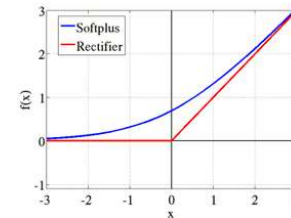
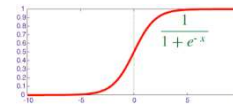
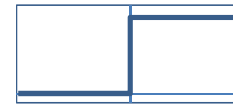

Activation functions $\sigma(z)$

- Perceptron
 - General setting, inputs are real valued
 - A *bias* b representing a threshold to trigger the perceptron
 - Activation functions are not necessarily threshold functions

Preliminaries: Redrawing the neuron

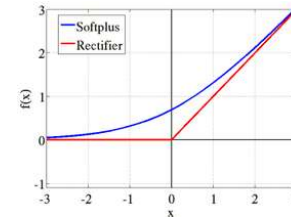
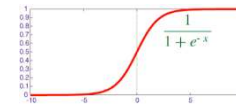
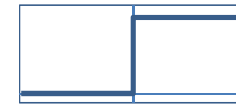
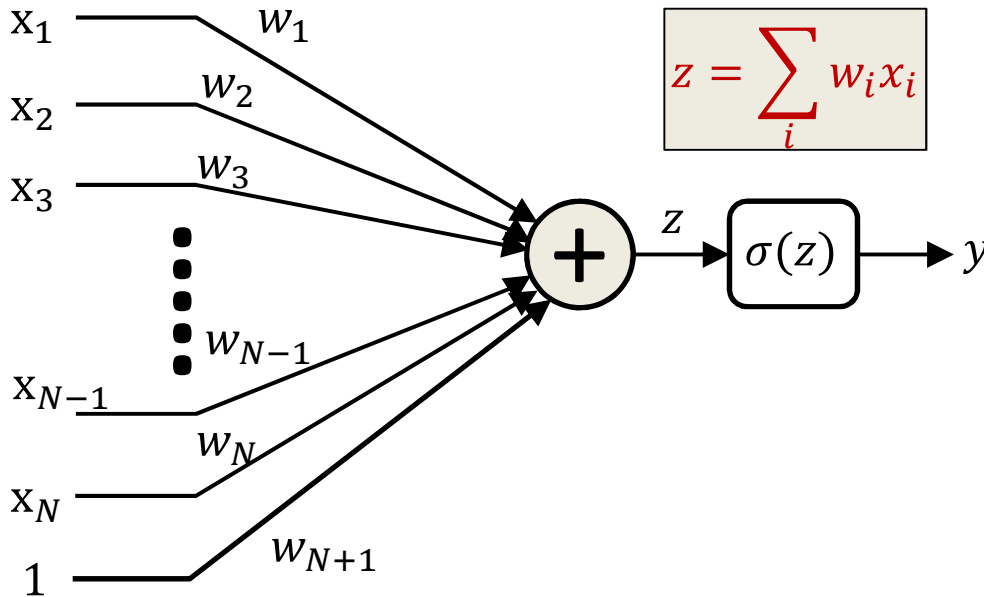

Activation functions $\sigma(z)$

- The bias can also be viewed as the weight of another input component that is always set to 1
 - If the bias is not explicitly mentioned, we will implicitly be assuming that every perceptron has an additional input that is always fixed at 1

First: the structure of the network

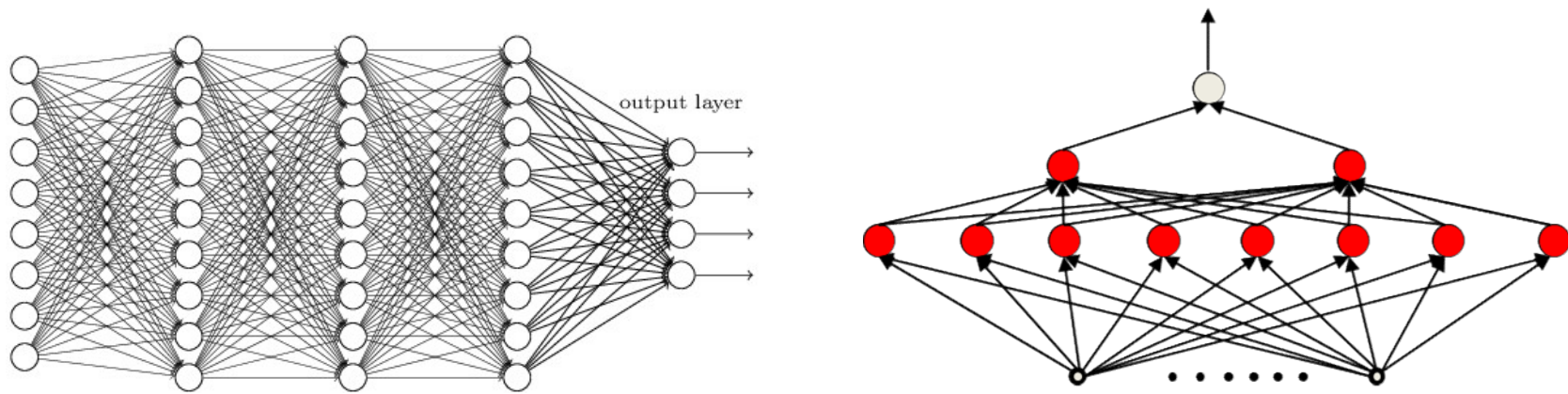

- We will assume a *feed-forward* network
 - No loops: Neuron outputs do not feed back to their inputs directly or indirectly
 - Loopy networks are a future topic
- **Part of the design of a network: The architecture**
 - How many layers/neurons, which neuron connects to which and how, etc.
- For now, assume the architecture of the network is capable of representing the needed function

What we learn: The parameters of the network

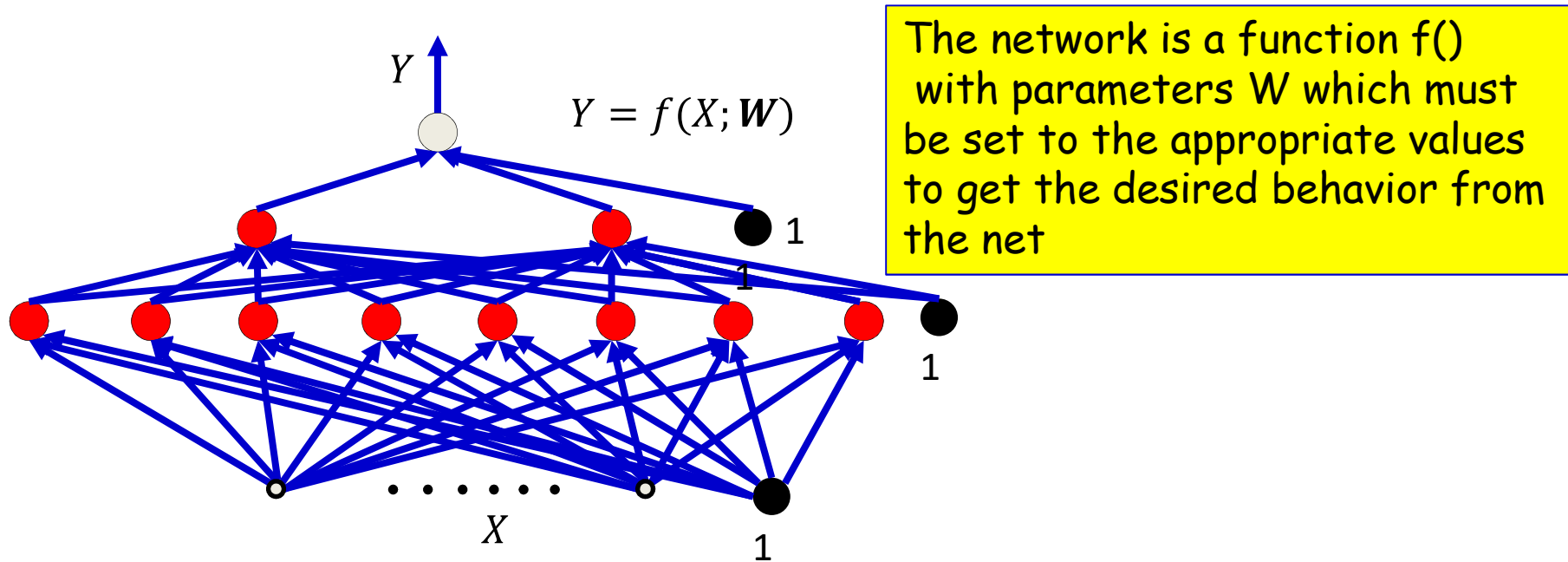

- **Given:** the architecture of the network
- **The parameters of the network:** The weights and biases
 - The weights associated with the blue arrows in the picture
- *Learning the network* : Determining the values of these parameters such that the network computes the desired function

- Moving on..

The MLP *can* represent anything

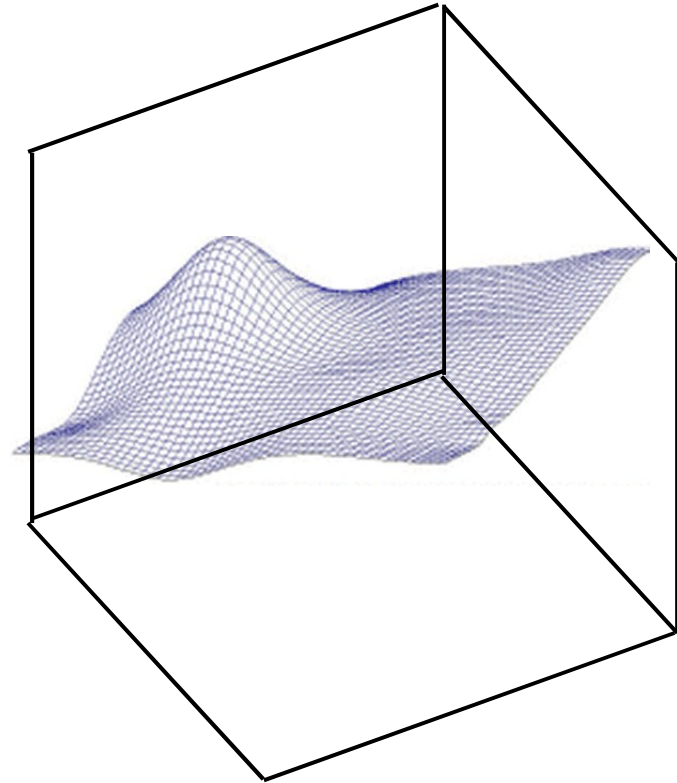
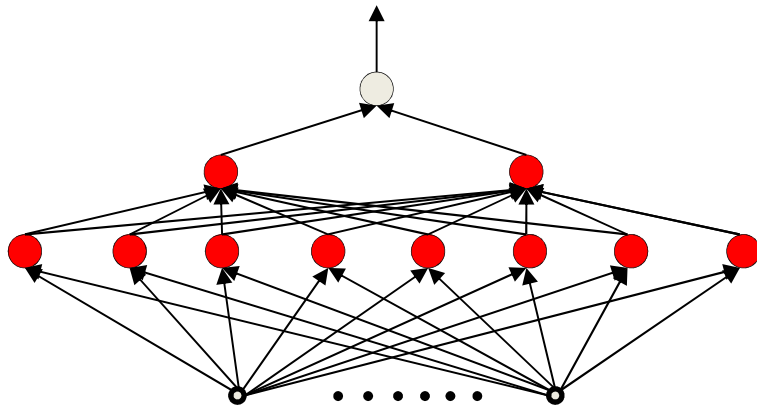

- The MLP *can be constructed* to represent anything
- But *how* do we construct it?

Option 1: Construct by hand

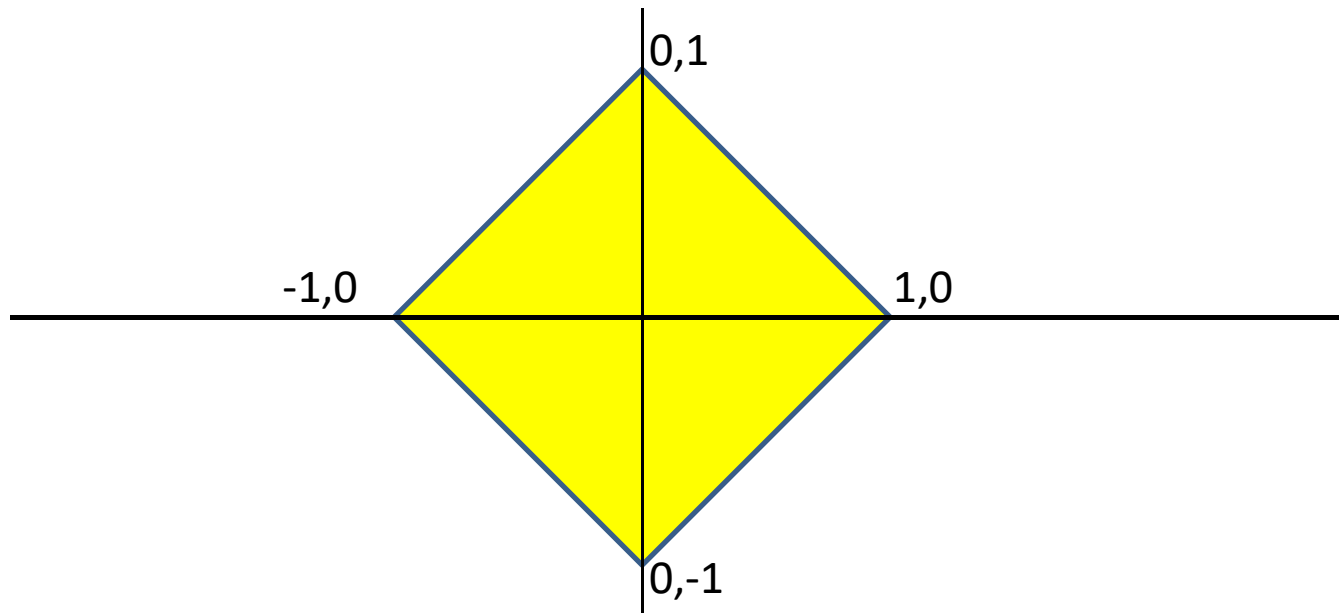

- Given a function, *handcraft* a network to satisfy it
- E.g.: Build an MLP to classify this decision boundary

Option 1: Construct by hand

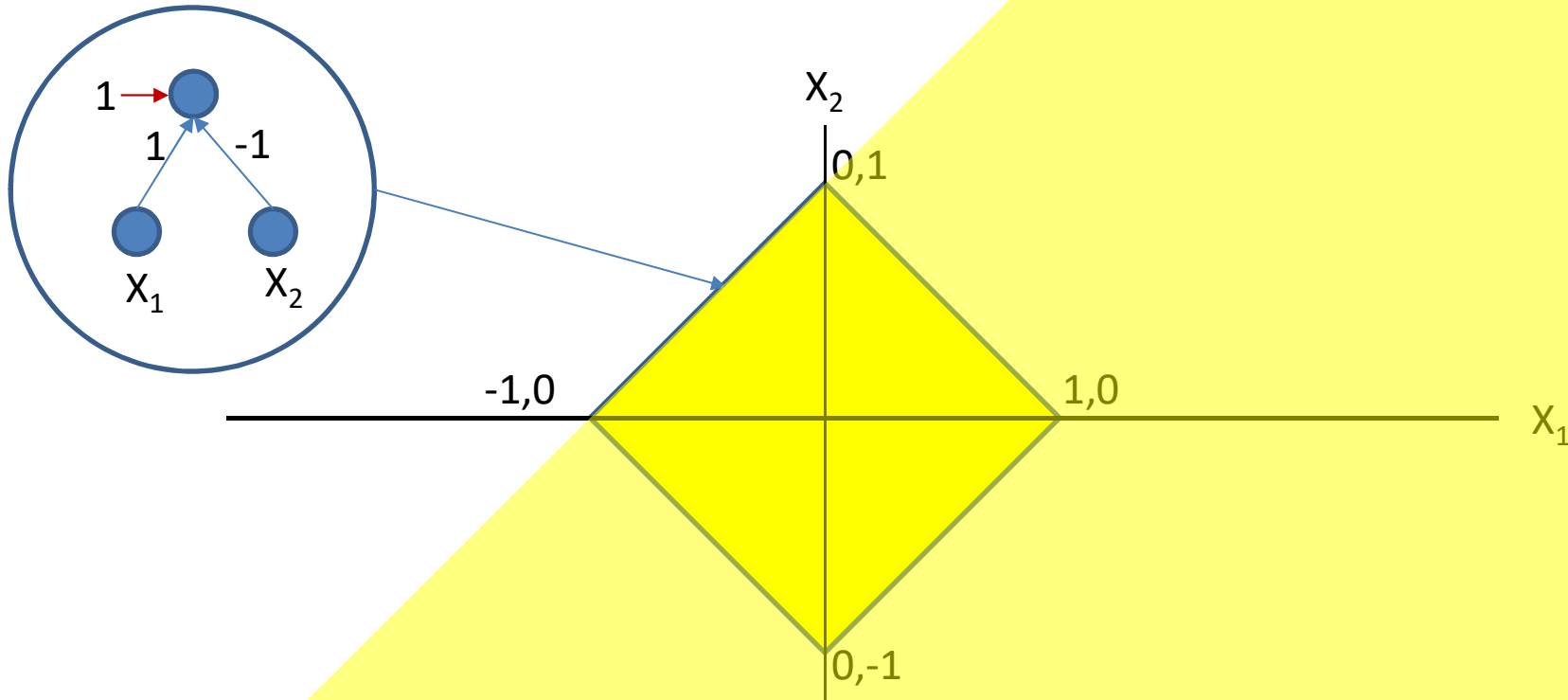

Assuming simple perceptrons:
output = 1 if $\sum_i w_i x_i + b_i \geq 0$, else 0

Option 1: Construct by hand

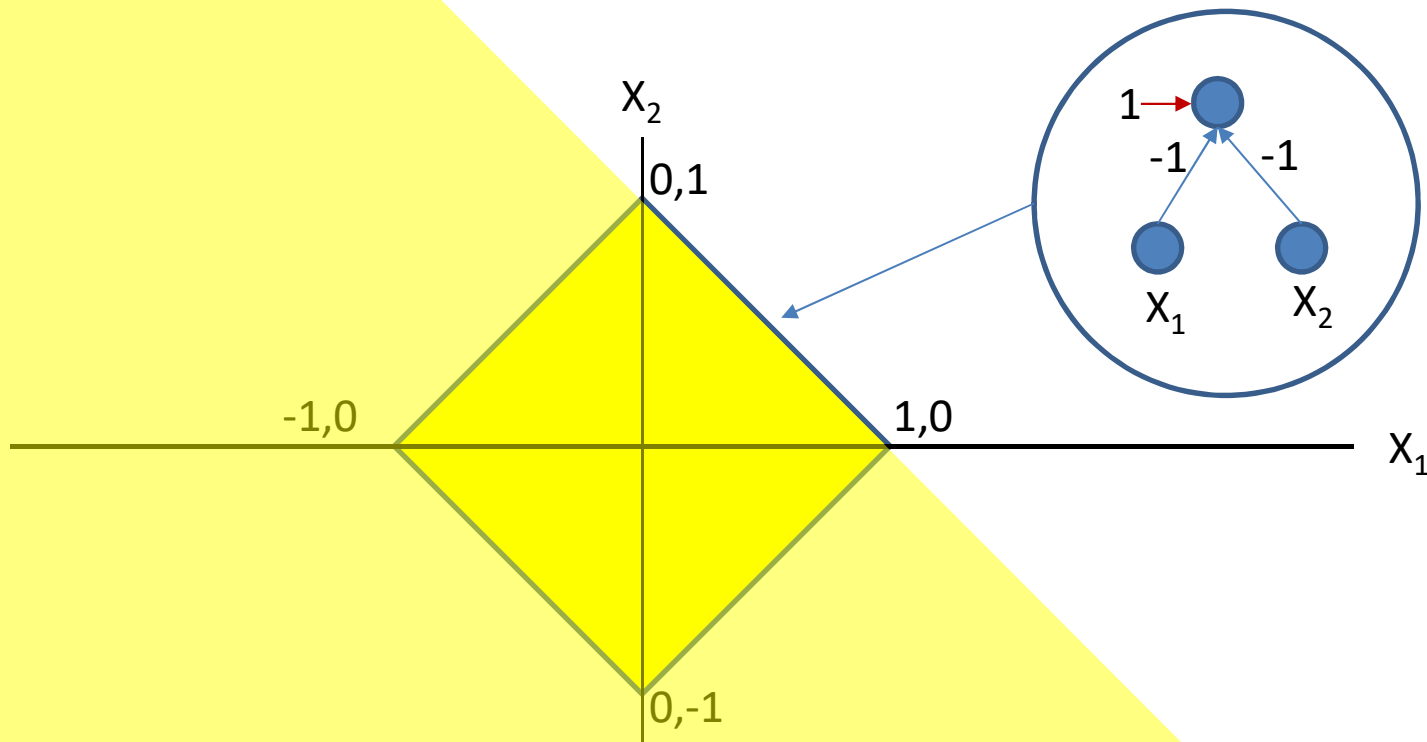

Assuming simple perceptrons:
output = 1 if $\sum_i w_i x_i + b_i \geq 0$, else 0

Option 1: Construct by hand

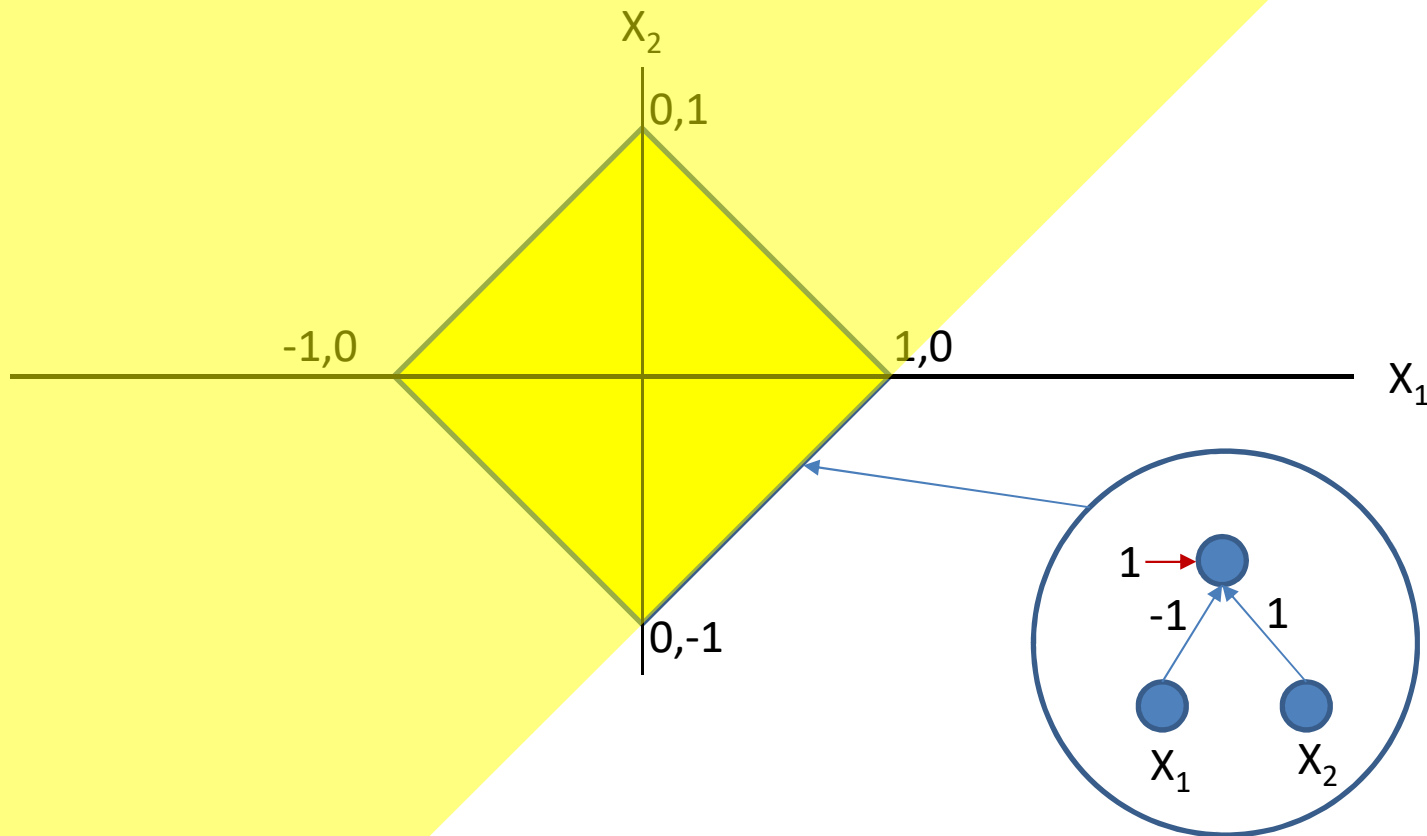

Assuming simple perceptrons:
output = 1 if $\sum_i w_i x_i + b_i \geq 0$, else 0

Option 1: Construct by hand

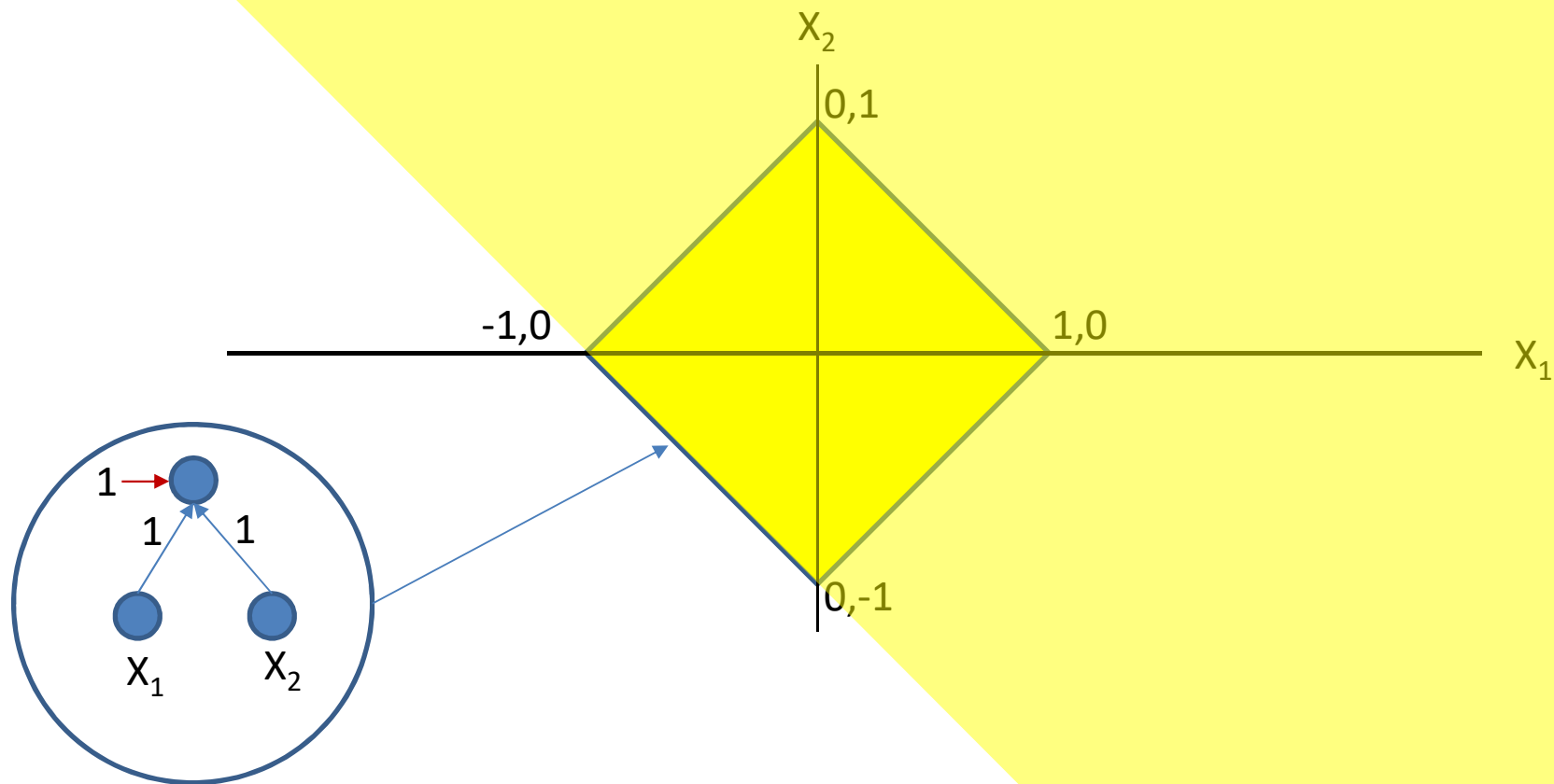

Assuming simple perceptrons:
output = 1 if $\sum_i w_i x_i + b_i \geq 0$, else 0

Option 1: Construct by hand

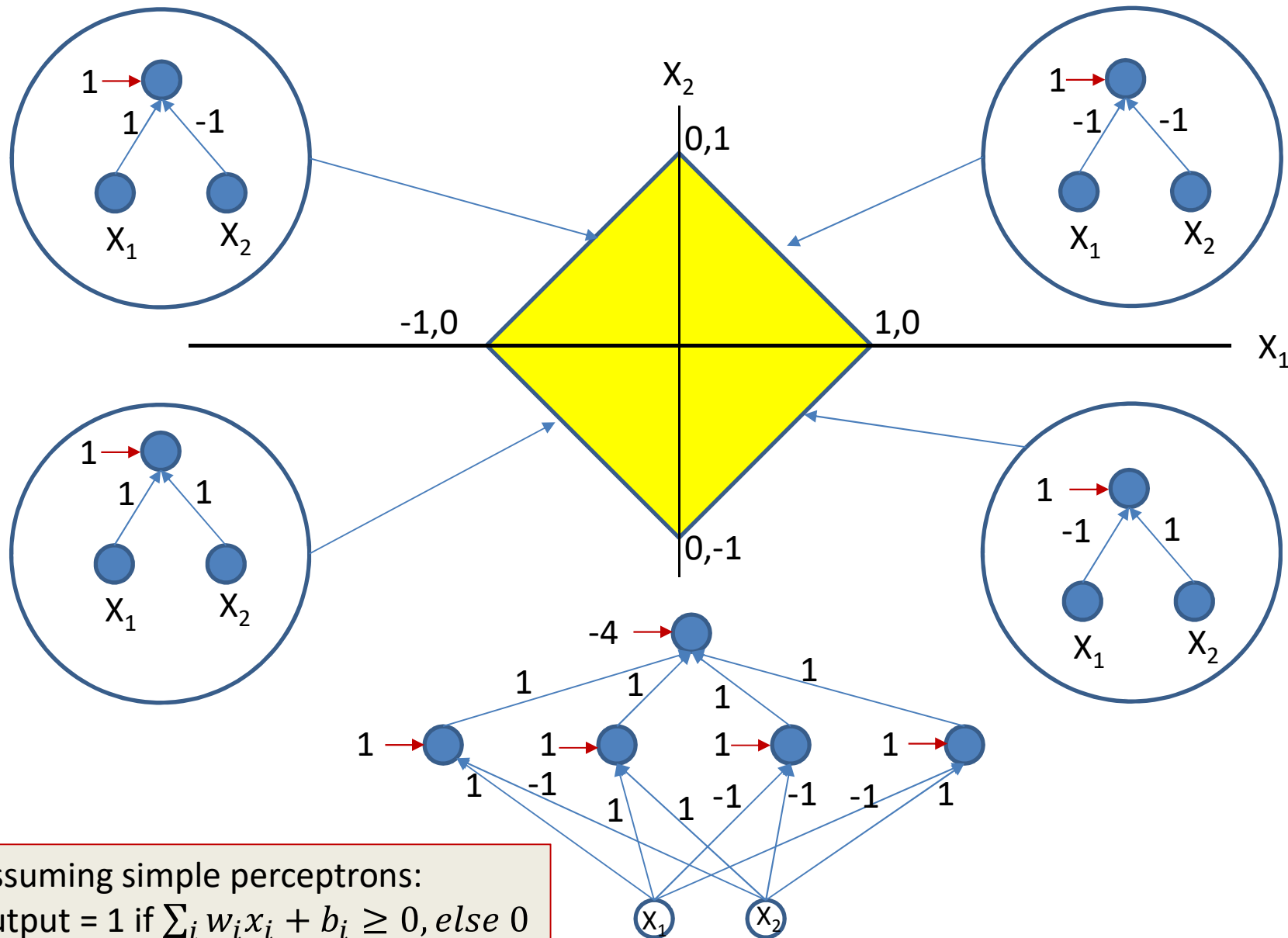

Assuming simple perceptrons:
 output = 1 if $\sum_i w_i x_i + b_i \geq 0$, else 0

Option 1: Construct by hand

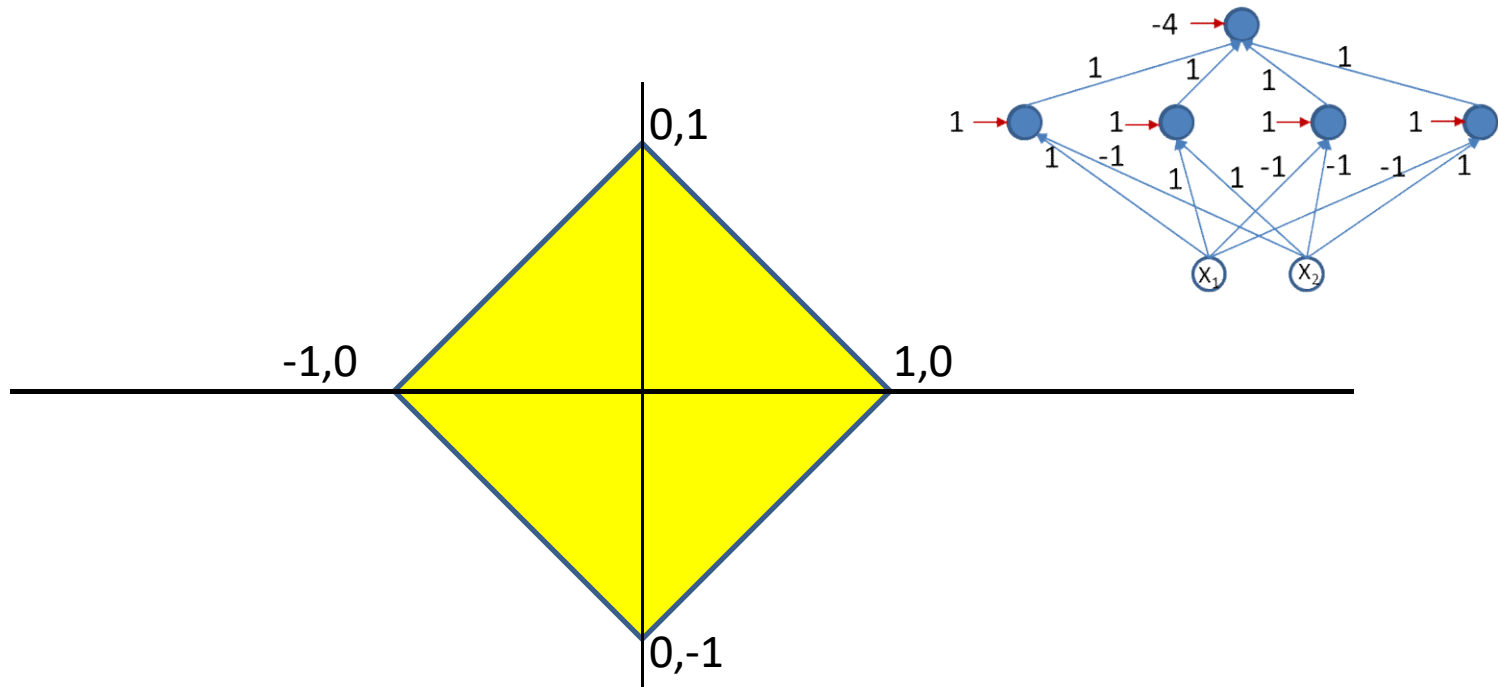

- Given a function, *handcraft* a network to satisfy it
- E.g.: Build an MLP to classify this decision boundary
- Not possible for all but the simplest problems..

Option 2: Automatic estimation of an MLP

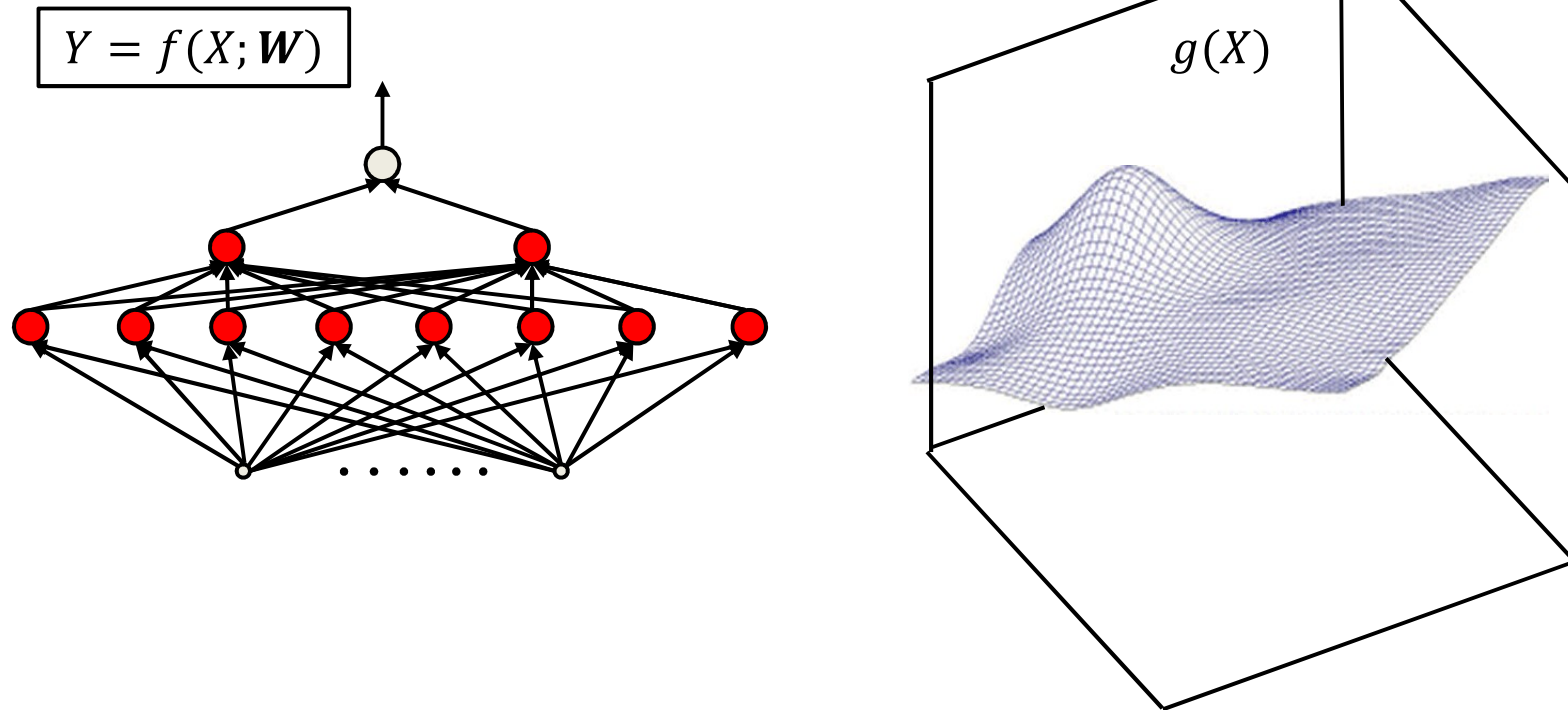

- More generally, *given* the function $g(X)$ to model, we can *derive* the parameters of the network to model it, through computation

How to learn a network?

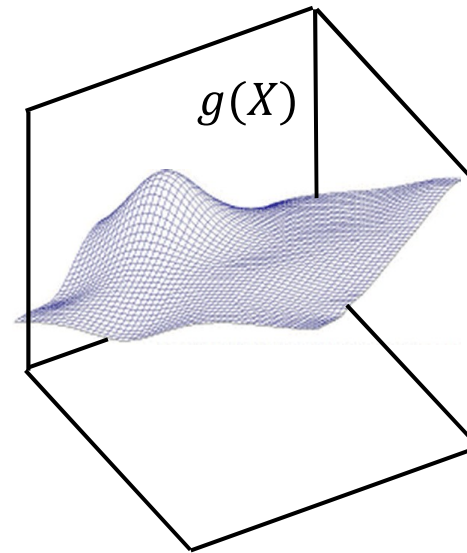
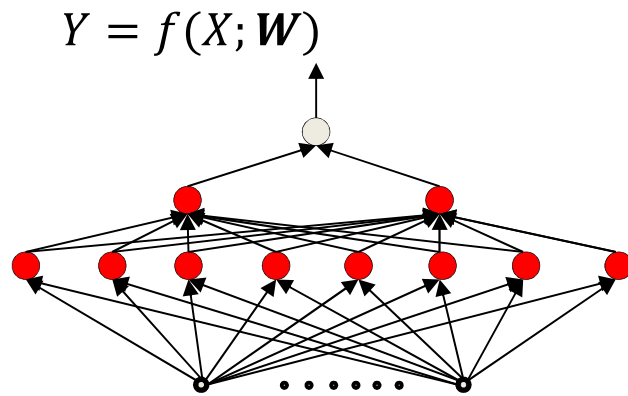

- When $f(X; \mathbf{W})$ has the capacity to exactly represent $g(X)$

$$\widehat{\mathbf{W}} = \operatorname{argmin}_{\mathbf{W}} \int_X \operatorname{div}(f(X; \mathbf{W}), g(X)) dX$$

- $\operatorname{div}()$ is a *divergence* function that goes to zero when $f(X; \mathbf{W}) = g(X)$

Problem $g(X)$ is unknown

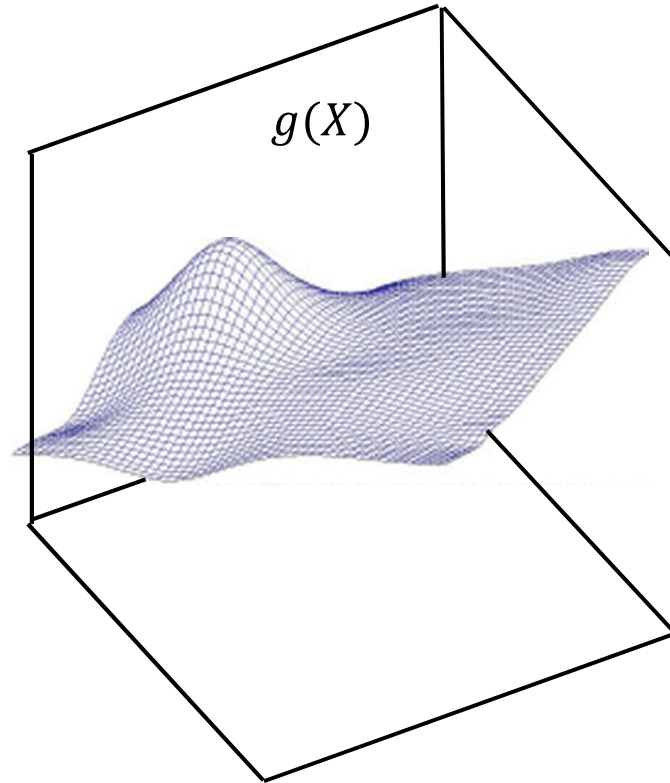

- Function $g(X)$ must be fully specified
 - Known *everywhere*, i.e. for *every* input X
- **In practice we will not have such specification**

Sampling the function

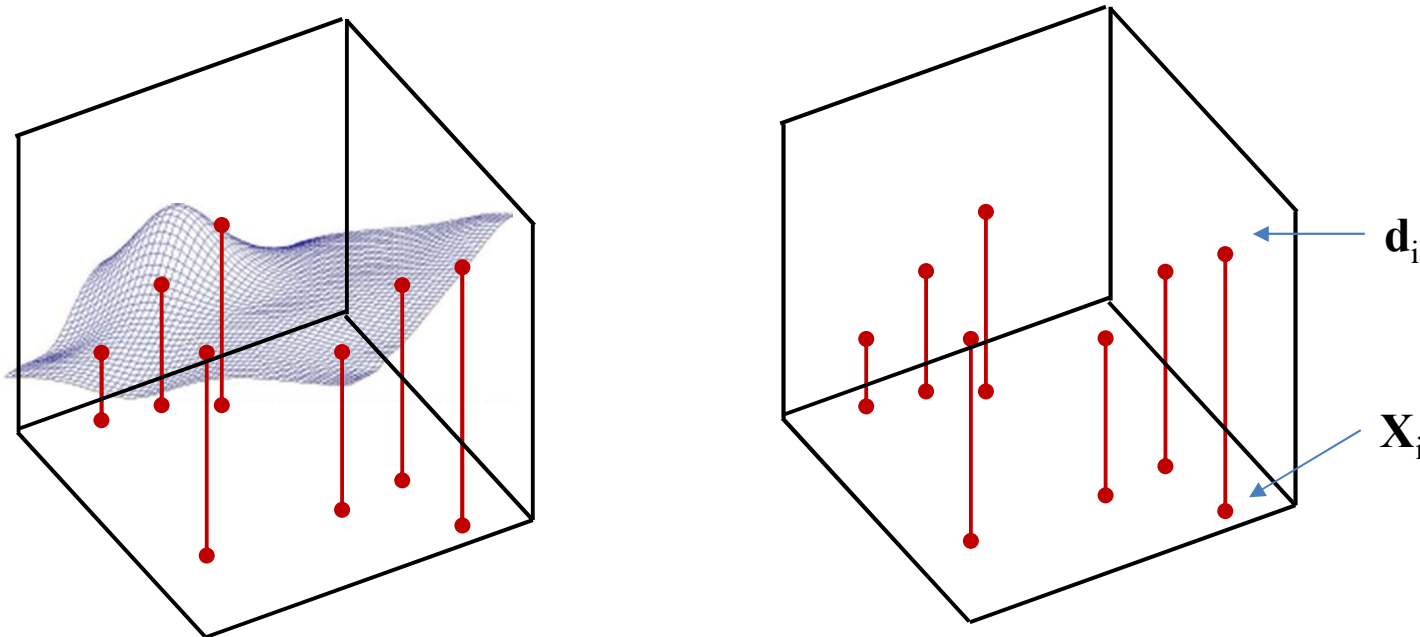

- *Sample $g(X)$*
 - Basically, get input-output pairs for a number of samples of input X_i
 - Many samples (X_i, d_i) , where $d_i = g(X_i) + noise$
 - Good sampling: the samples of X will be drawn from $P(X)$
- Very easy to do in most problems: just gather training data
 - E.g. set of images and their class labels
 - E.g. speech recordings and their transcription

Drawing samples

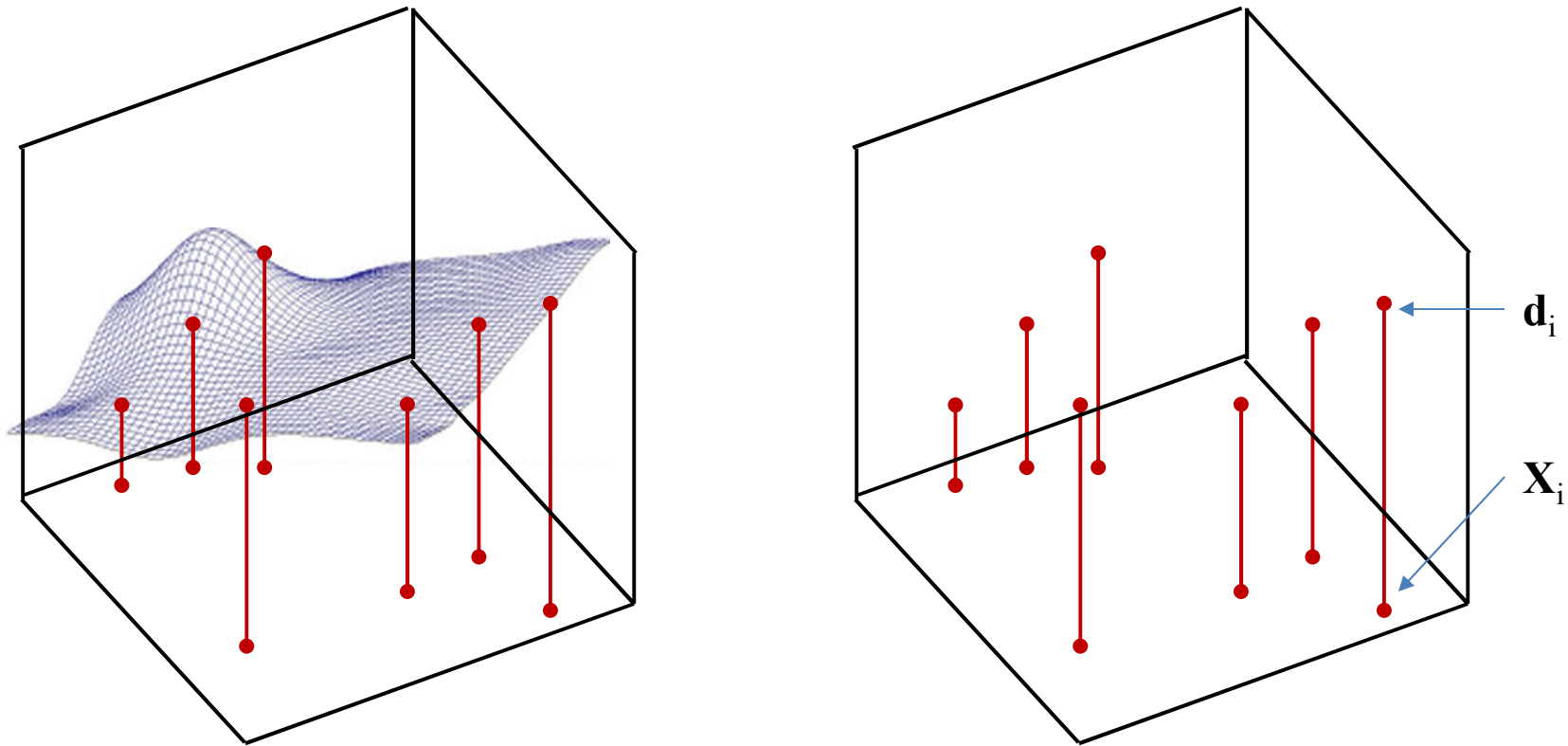

- We must *learn* the *entire* function from these few examples
 - The “training” samples

Learning the function

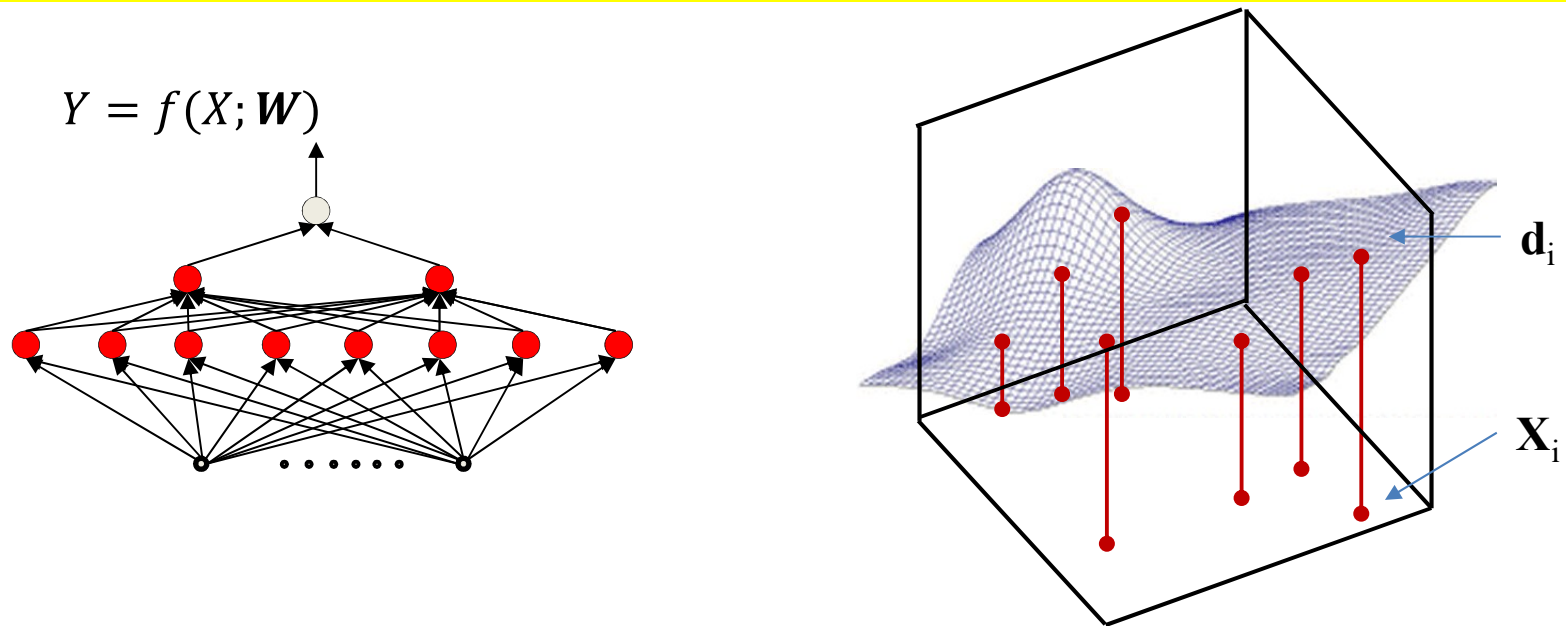

- Estimate the network parameters to “fit” the training points exactly
 - Assuming network architecture is sufficient for such a fit
 - Assuming unique output d at any X
 - And hopefully the resulting function is also correct where we *don't* have training samples

Story so far

- “Learning” a neural network == determining the parameters of the network (weights and biases) required for it to model a desired function
 - The network must have sufficient capacity to model the function
- Ideally, we would like to optimize the network to represent the desired function everywhere
- However this requires knowledge of the function everywhere
- Instead, we draw “input-output” *training* instances from the function and estimate network parameters to “fit” the input-output relation at these instances
 - And hope it fits the function elsewhere as well

Lets begin with a simple task

- Learning a *classifier*
 - Simpler than regressions
- This was among the earliest problems addressed using MLPs
- Specifically, consider *binary* classification
 - Generalizes to multi-class

History: The original MLP

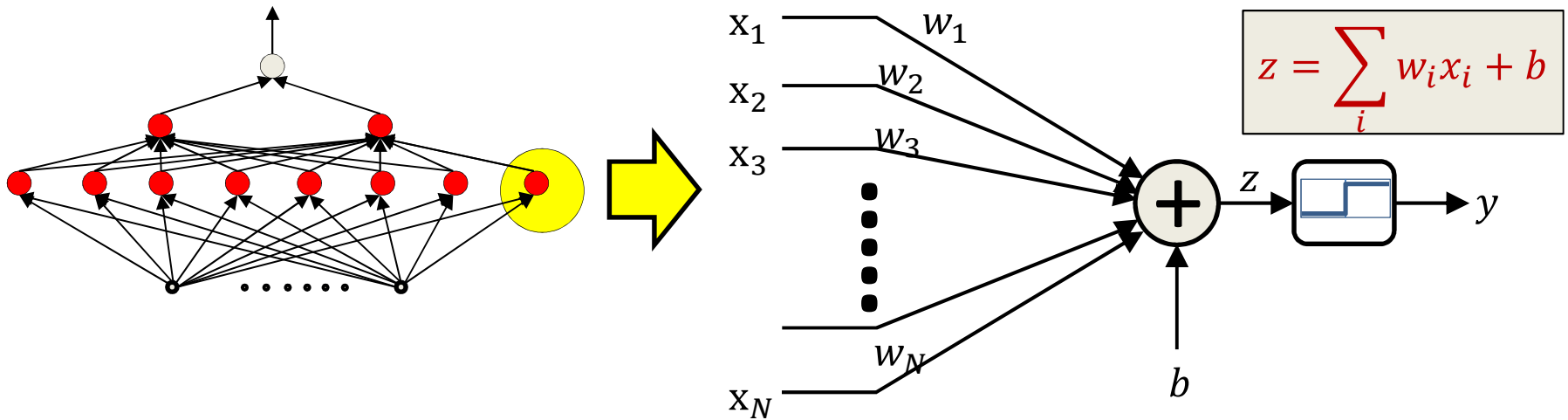

- The original MLP as proposed by Minsky: a network of threshold units
 - But how do you train it?
 - Given only “training” instances of input-output pairs

The simplest MLP: a single perceptron

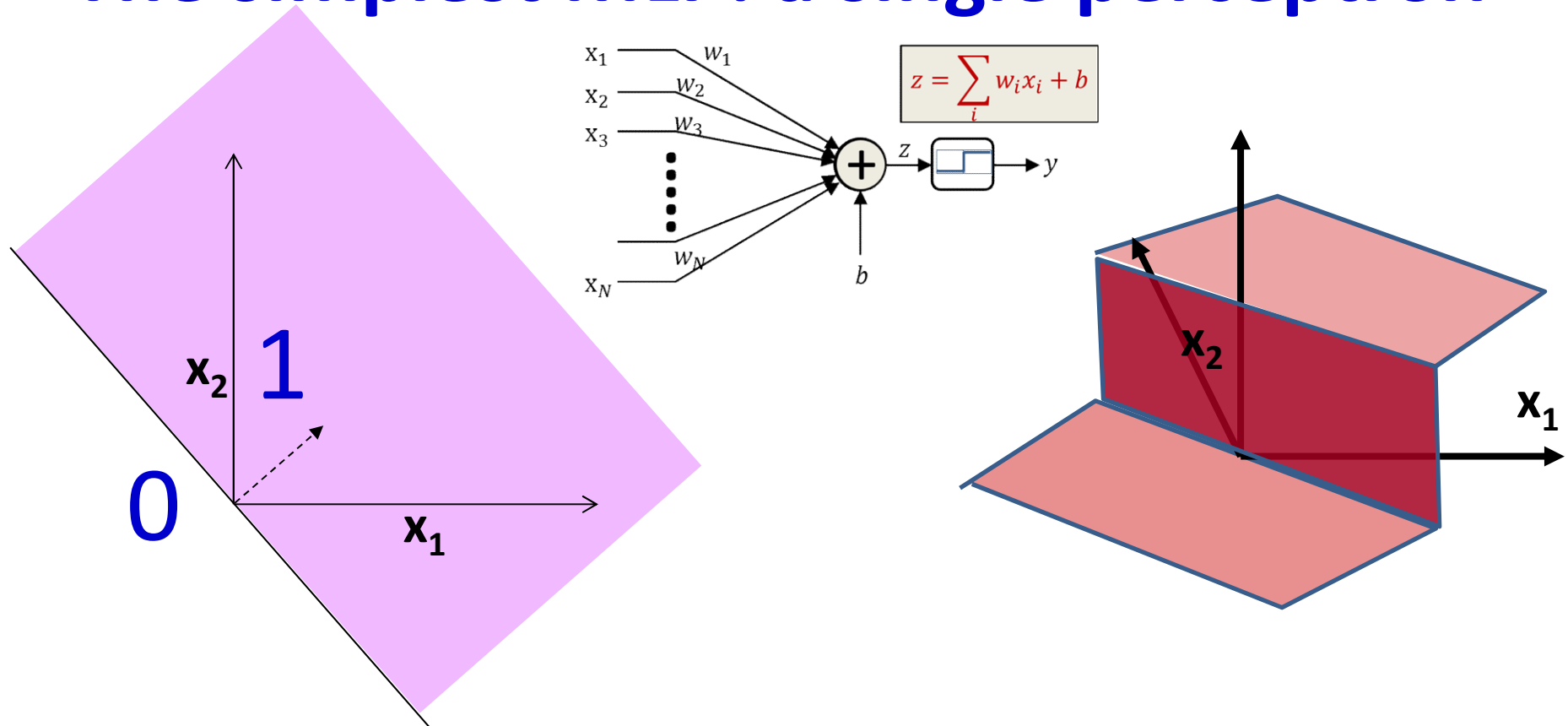

- Learn this function
 - A step function across a hyperplane

The simplest MLP: a single perceptron

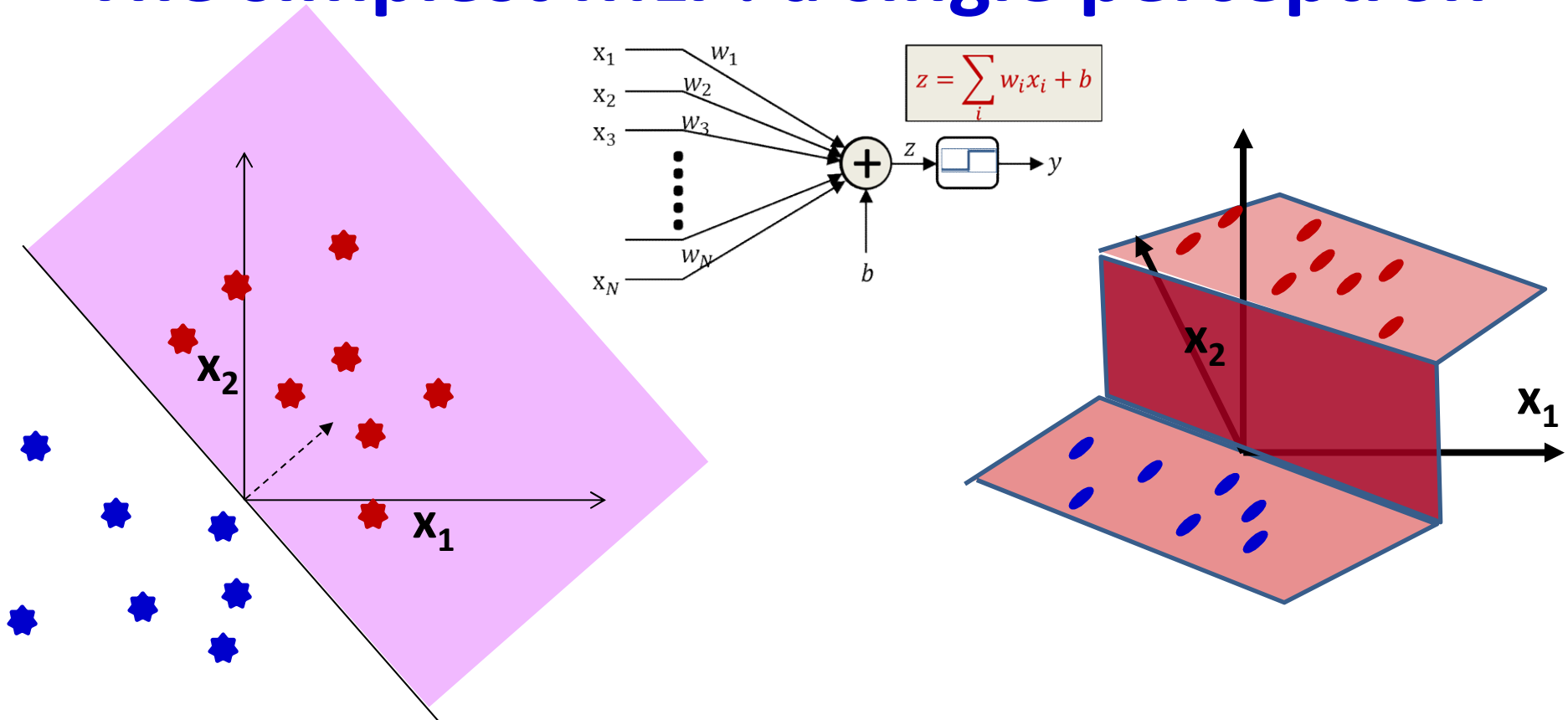

- Learn this function
 - A step function across a hyperplane
 - Given only samples from it

Learning the perceptron

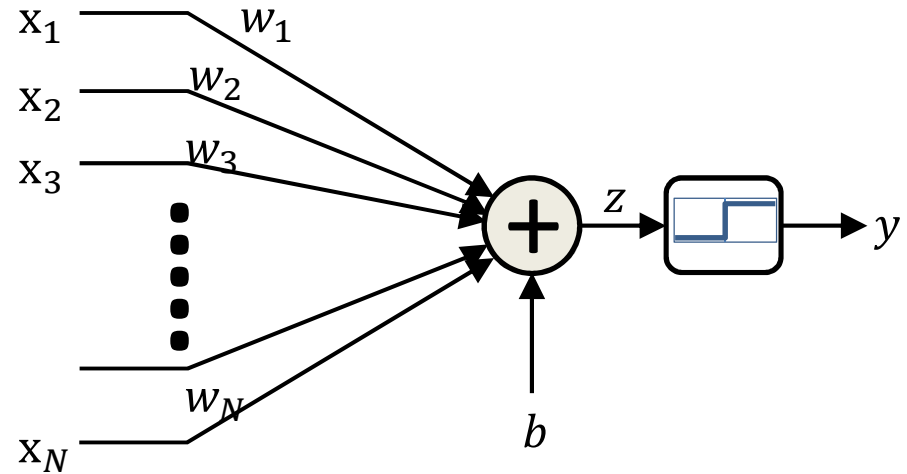
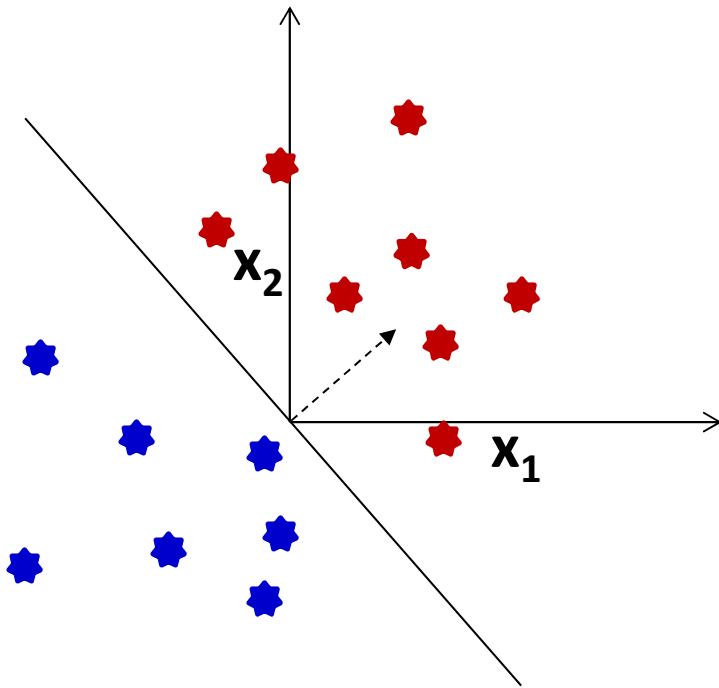

- Given a number of input output pairs, learn the weights and bias

$$- y = \begin{cases} 1 & \text{if } \sum_{i=1}^N w_i X_i + b \geq 0 \\ 0 & \text{otherwise} \end{cases}$$

- Learn $W = [w_1 \dots w_N]^T$ and b , given several (X, y) pairs

Restating the perceptron

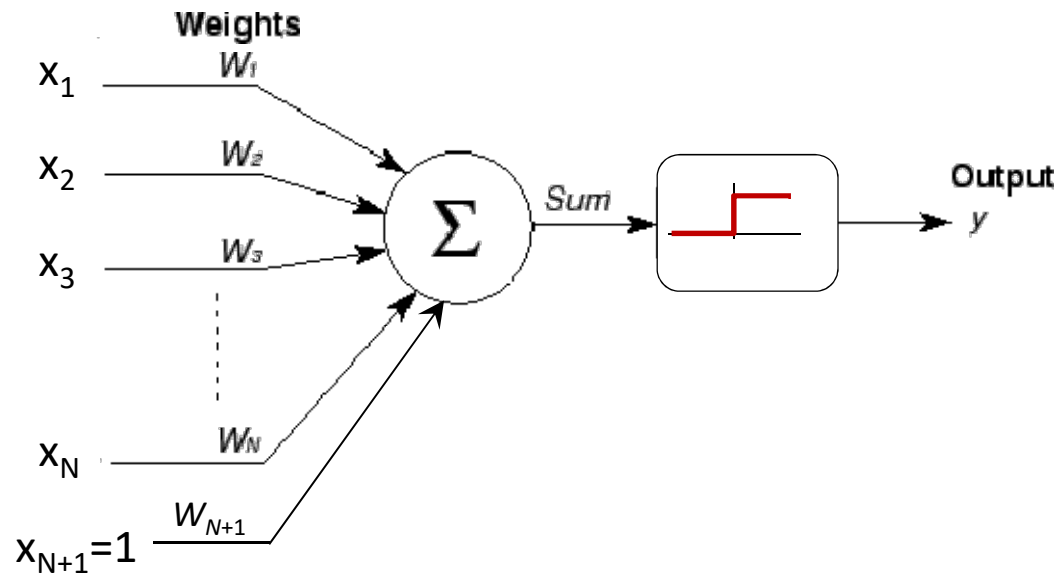

- Restating the perceptron equation by adding another dimension to X

$$y = \begin{cases} 1 & \text{if } \sum_{i=1}^{N+1} w_i X_i \geq 0 \\ 0 & \text{otherwise} \end{cases}$$

where $X_{N+1} = 1$

- Note that the boundary $\sum_{i=1}^{N+1} w_i X_i \geq 0$ is now a hyperplane through origin

The Perceptron Problem

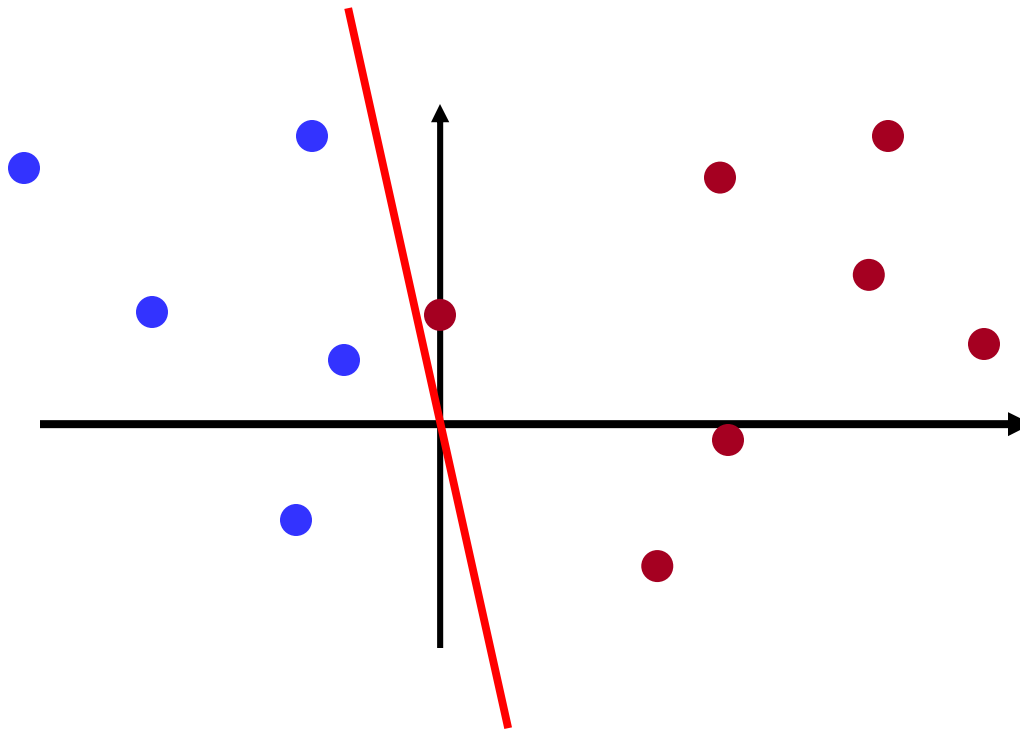

- Find the hyperplane $\sum_{i=1}^{N+1} w_i X_i = 0$ that perfectly separates the two groups of points

The Perceptron Problem

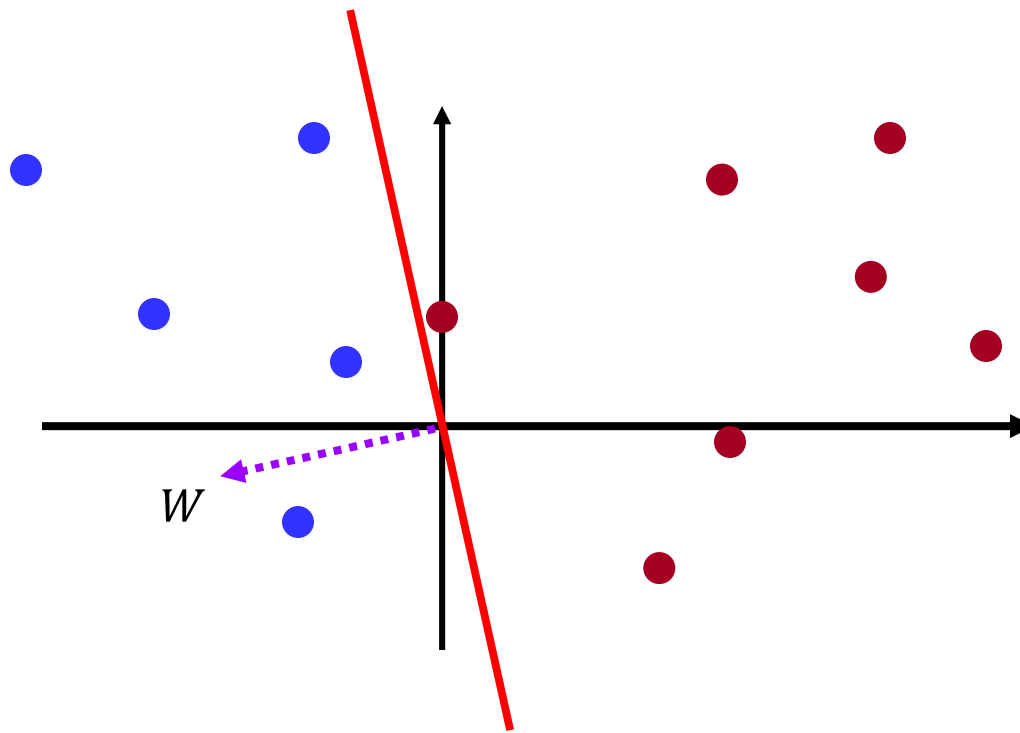

- Find the hyperplane $\sum_{i=1}^{N+1} w_i X_i = 0$ that perfectly separates the two groups of points
 - Note: $W = [w_1, w_2, \dots, w_{N+1}]^T$ is a vector that is orthogonal to the hyperplane
 - In fact the equation for the hyperplane itself means “the set of all X s that are orthogonal to W ” ($\sum_{i=1}^{N+1} w_i X_i = W^T X = 0$)

The Perceptron Problem

Key: Red -1, Blue = +1

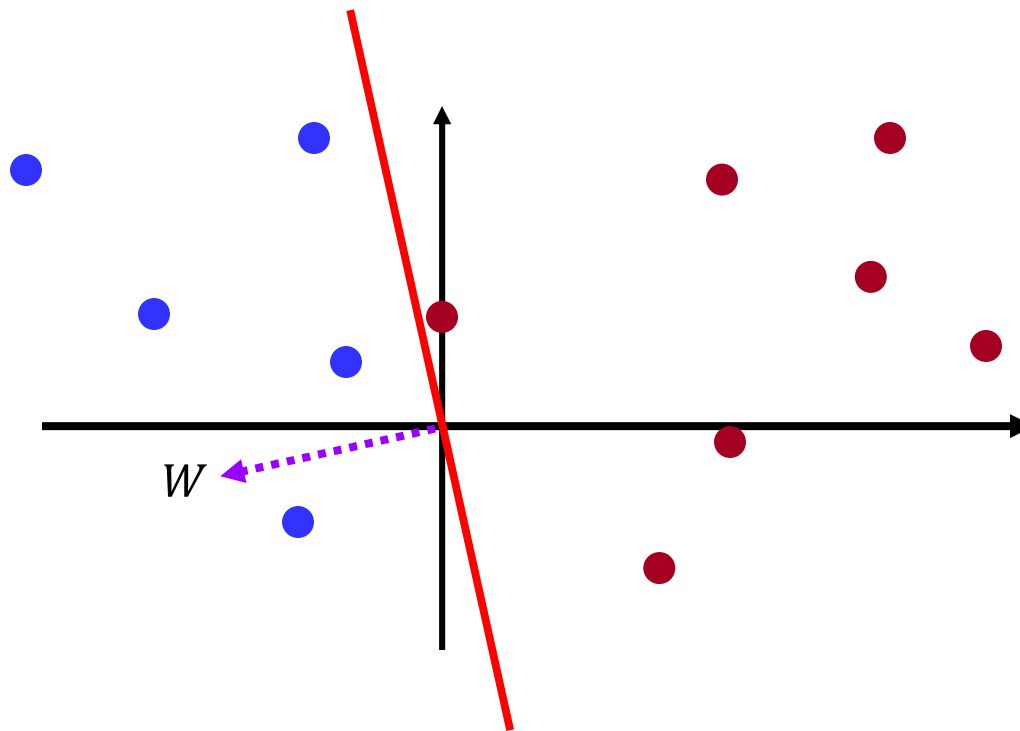

- Learning the perceptron: Find the weights vector W such that $W^T X$ is positive for all blue dots and negative for all red ones

Perceptron Algorithm: Summary

- Cycle through the training instances
- Only update W on misclassified instances
- If instance misclassified:
 - If instance is positive class (positive misclassified as negative)

$$W = W + X_i$$

- If instance is negative class (negative misclassified as positive)

$$W = W - X_i$$

Perceptron Learning Algorithm

- Given N training instances $(X_1, y_1), (X_2, y_2), \dots, (X_N, y_N)$
 - $y_i = +1$ or -1

Using a +1/-1 representation for classes to simplify notation

- Initialize W
- Cycle through the training instances:
- do

– For $i = 1 \dots N_{train}$
 $O(X_i) = \text{sign}(W^T X_i)$

- If $O(X_i) \neq y_i$
 $W = W + y_i X_i$

- until no more classification errors

A Simple Method: The Perceptron Algorithm

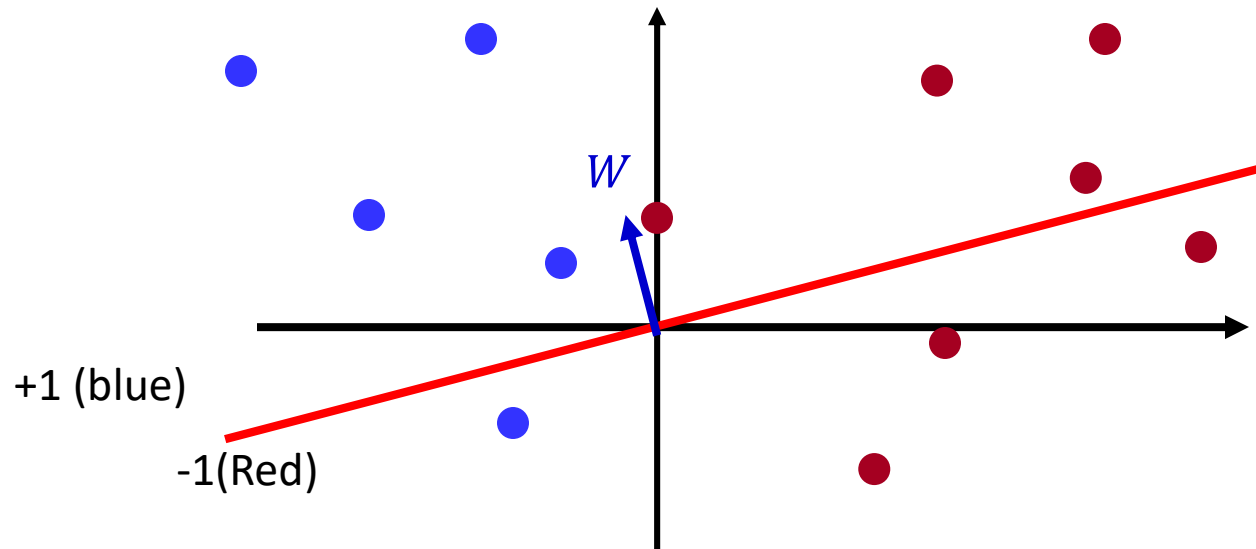

- **Initialize:** Randomly initialize the hyperplane
 - I.e. randomly initialize the normal vector W
- **Classification rule** $\text{sign}(W^T X)$
 - Vectors on the same side of the hyperplane as W will be assigned +1 class, and those on the other side will be assigned -1
- The random initial plane will make mistakes

Perceptron Algorithm

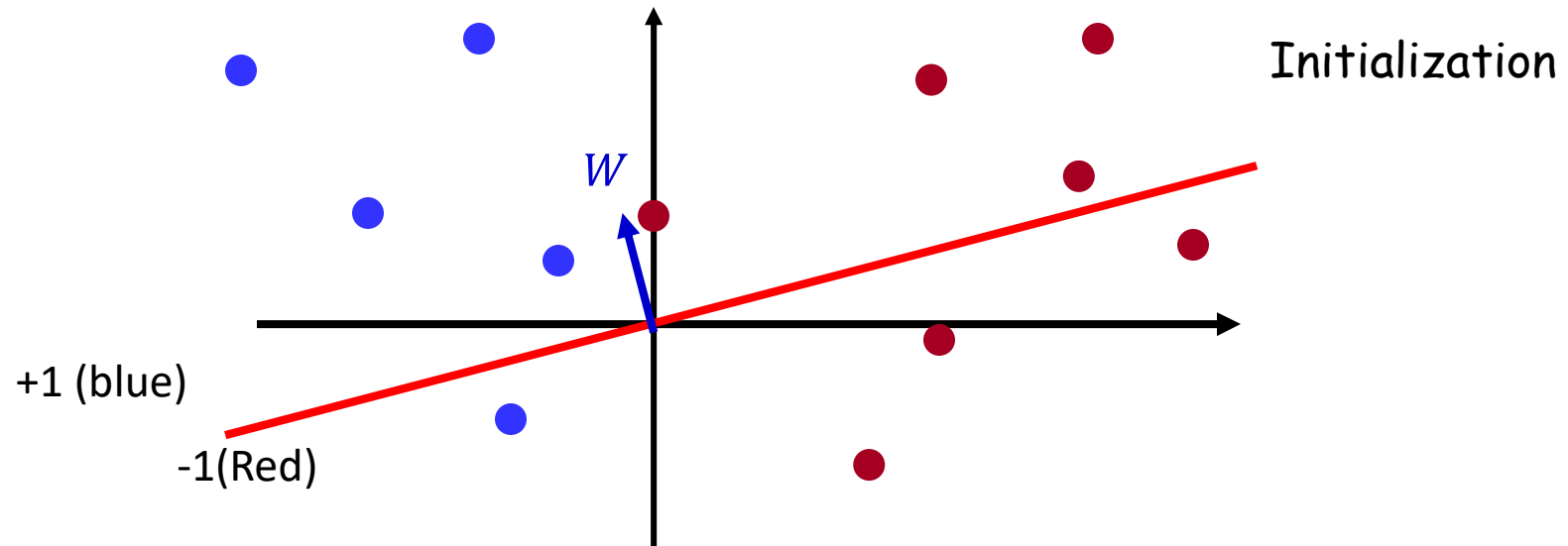

Perceptron Algorithm

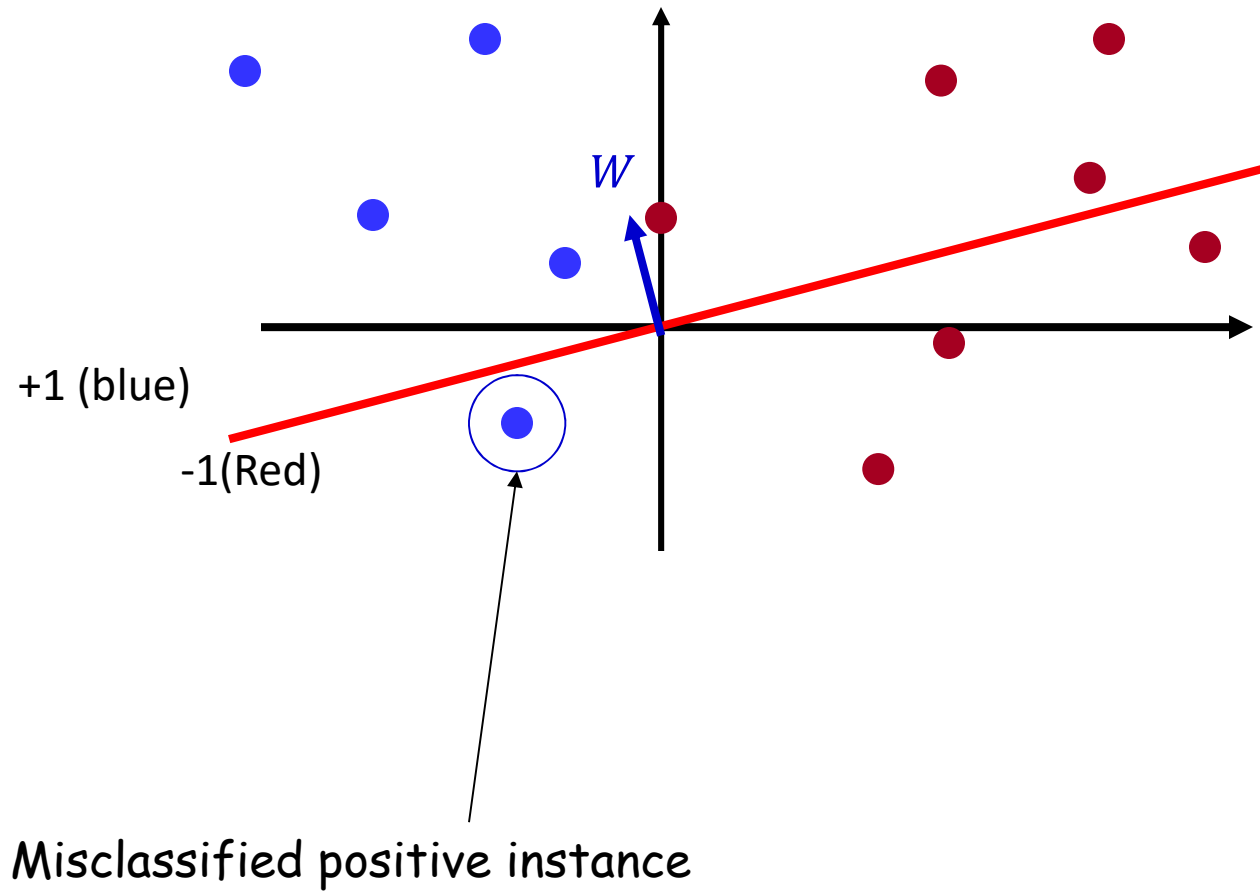

Perceptron Algorithm

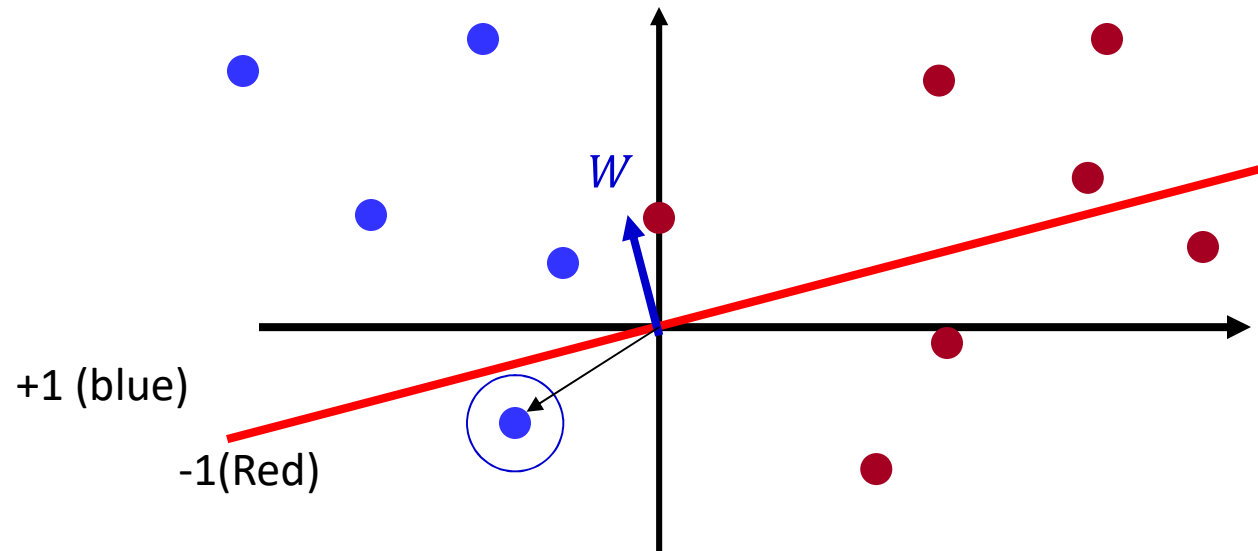

Perceptron Algorithm

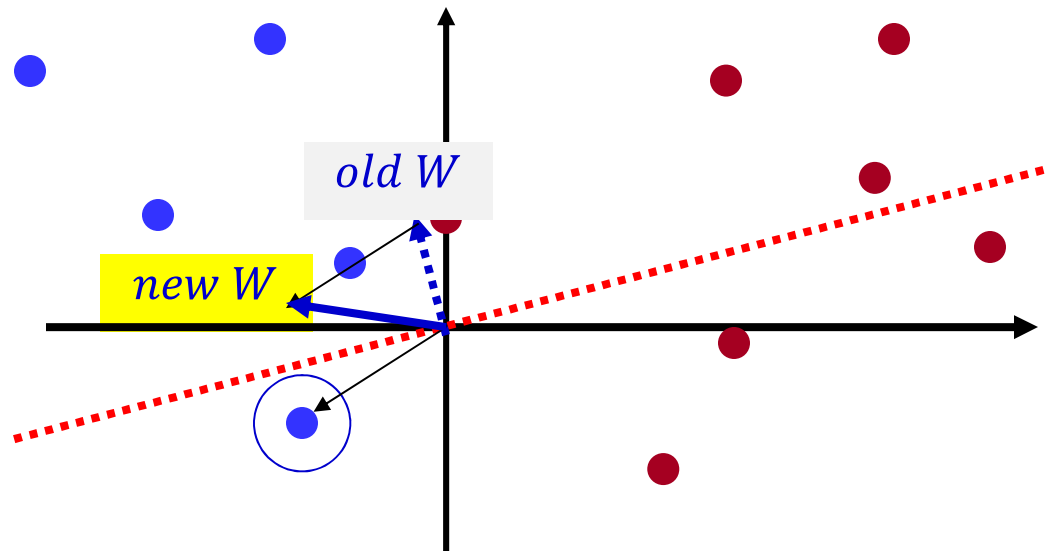

Updated weight vector

Misclassified *positive* instance, *add* it to W

Perceptron Algorithm

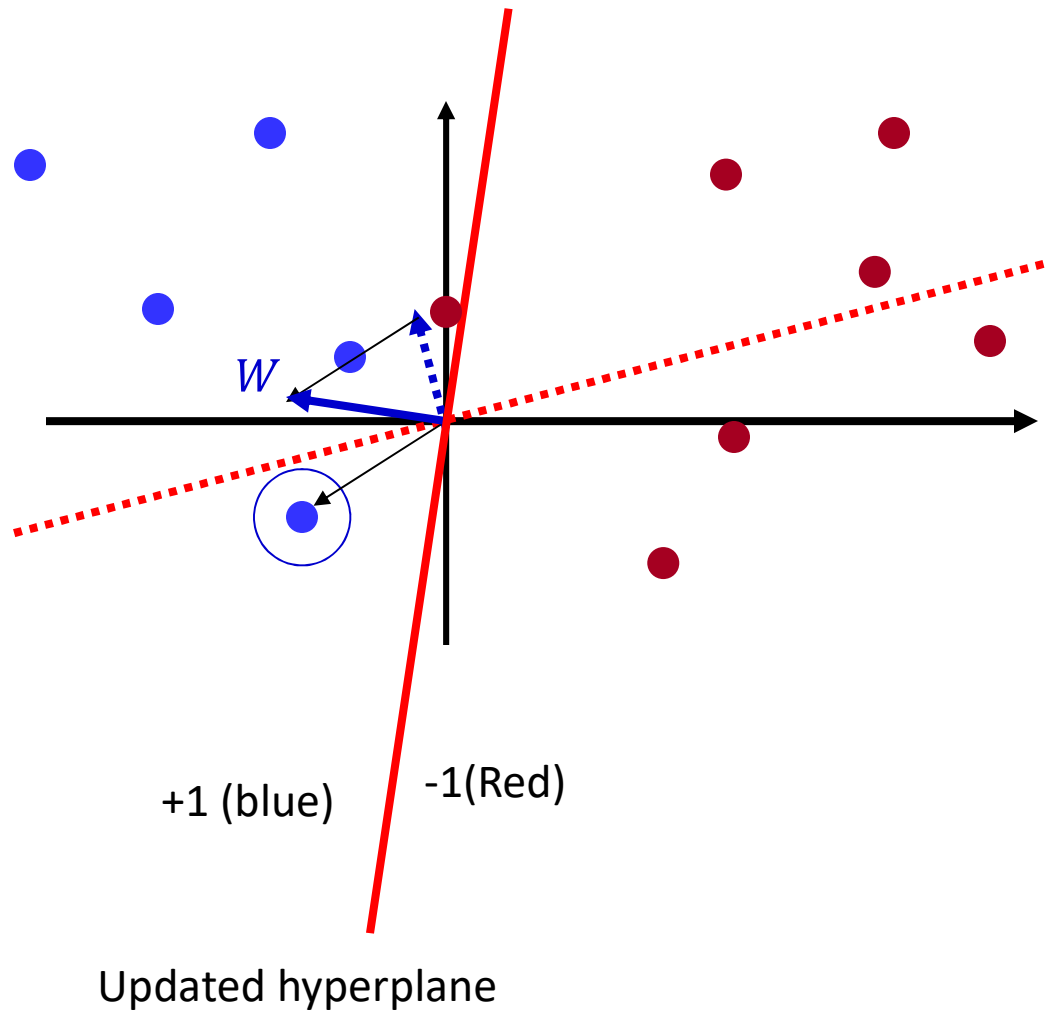

Perceptron Algorithm

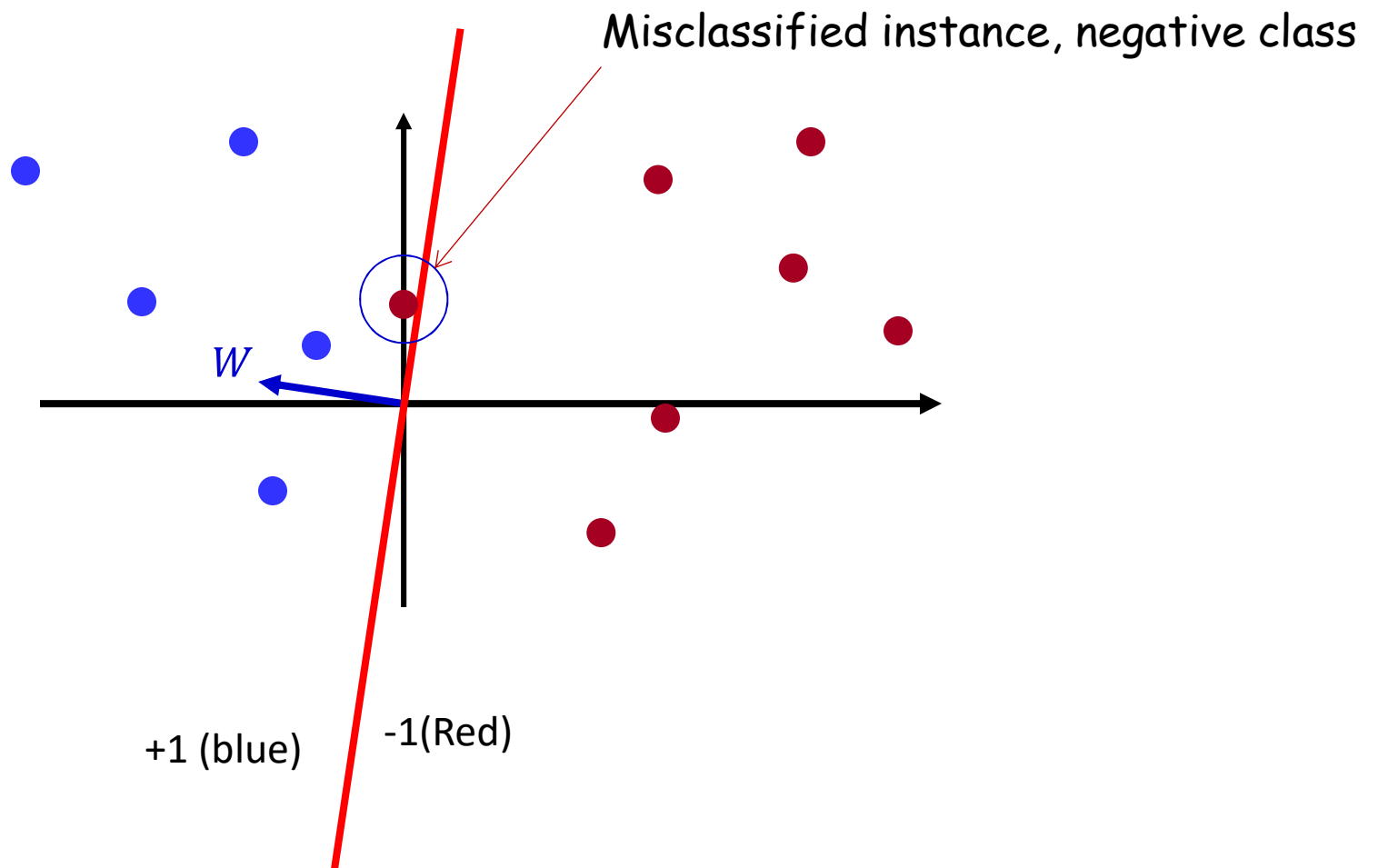

Perceptron Algorithm

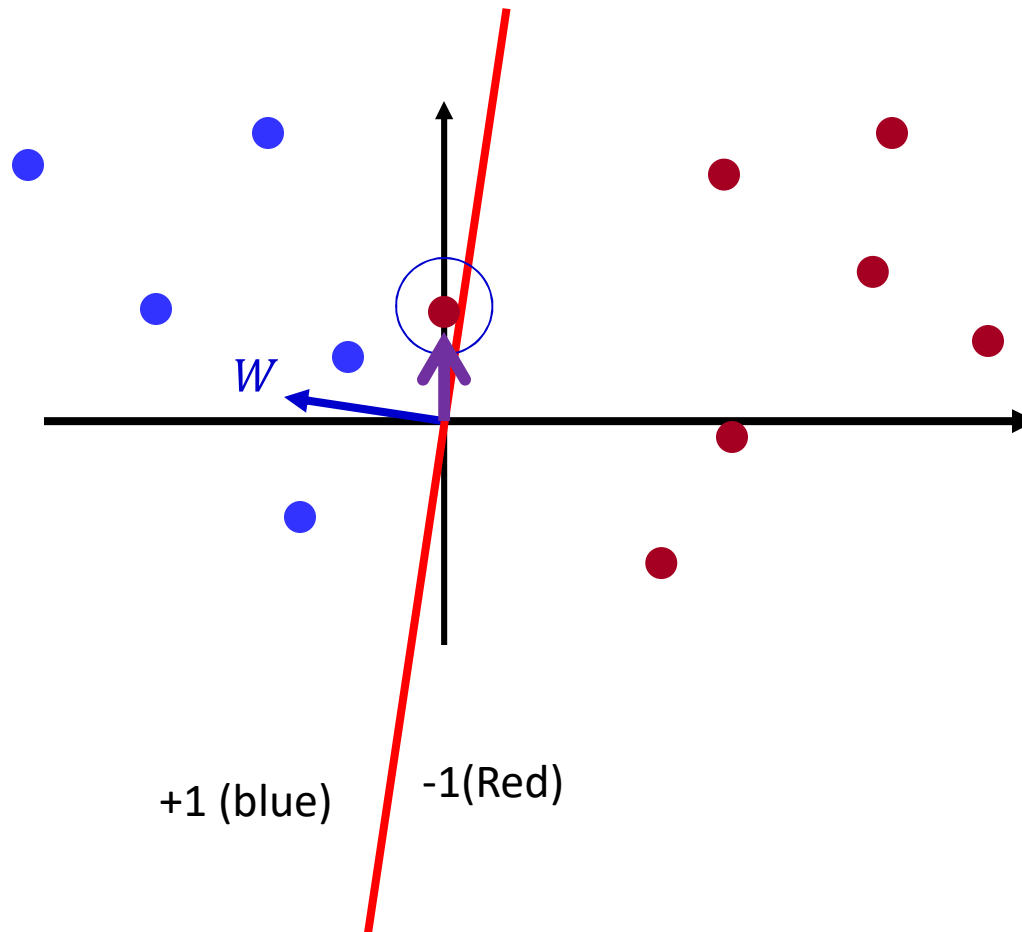

Perceptron Algorithm

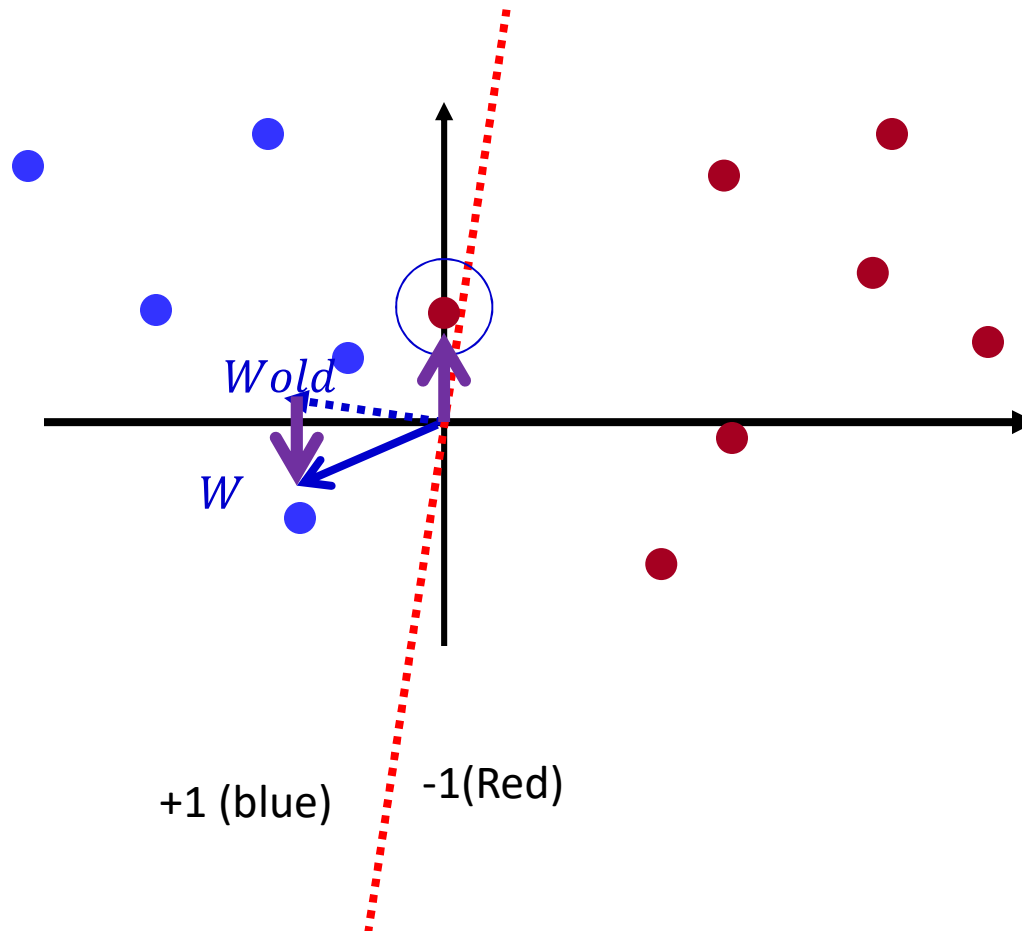

Misclassified *negative* instance, *subtract* it from W

Perceptron Algorithm

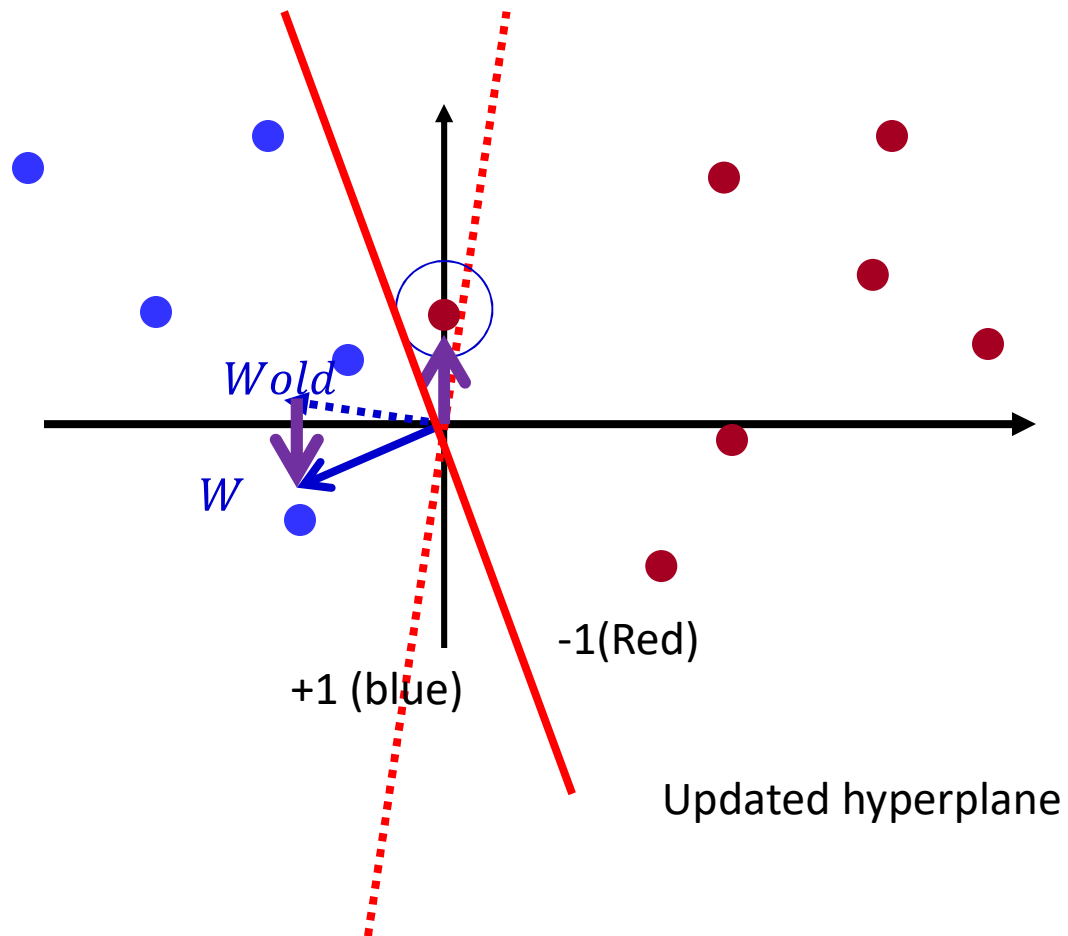

Perceptron Algorithm

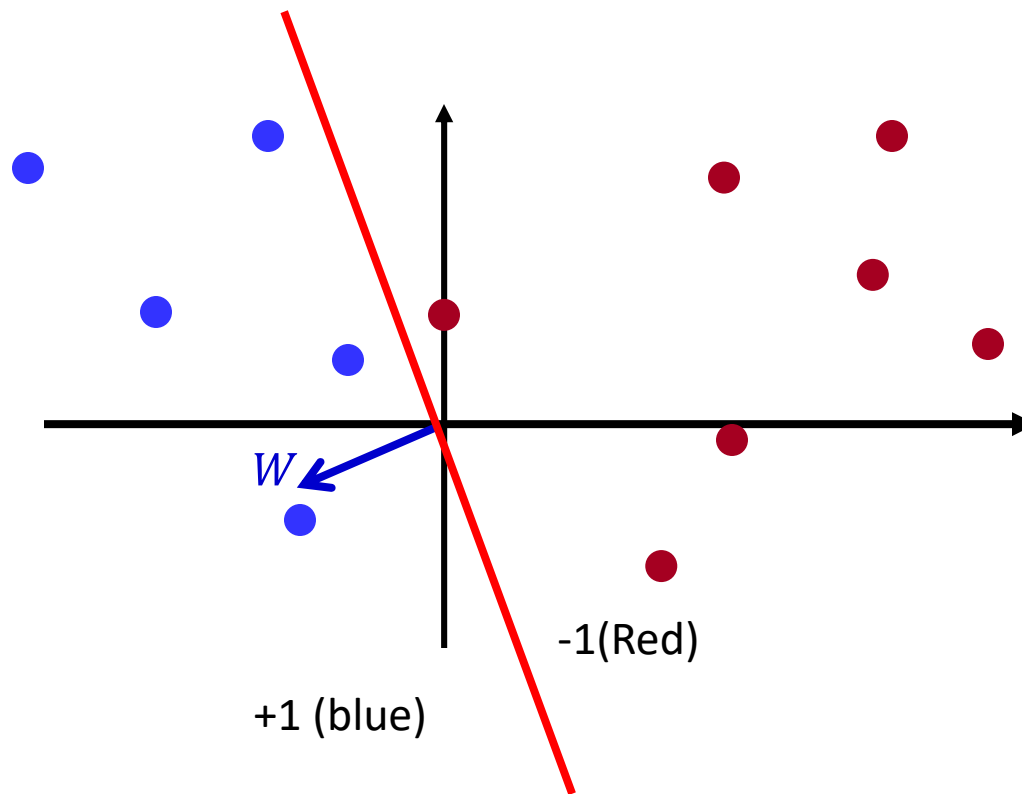

Perfect classification, no more updates

Convergence of Perceptron Algorithm

- Guaranteed to converge if classes are linearly separable
 - After no more than $\left(\frac{R}{\gamma}\right)^2$ misclassifications
 - Specifically when W is initialized to 0
 - R is length of longest training point
 - γ is the *best case* closest distance of a training point from the classifier
 - Same as the margin in an SVM
 - Intuitively – takes many increments of size γ to undo an error resulting from a step of size R

Perceptron Algorithm

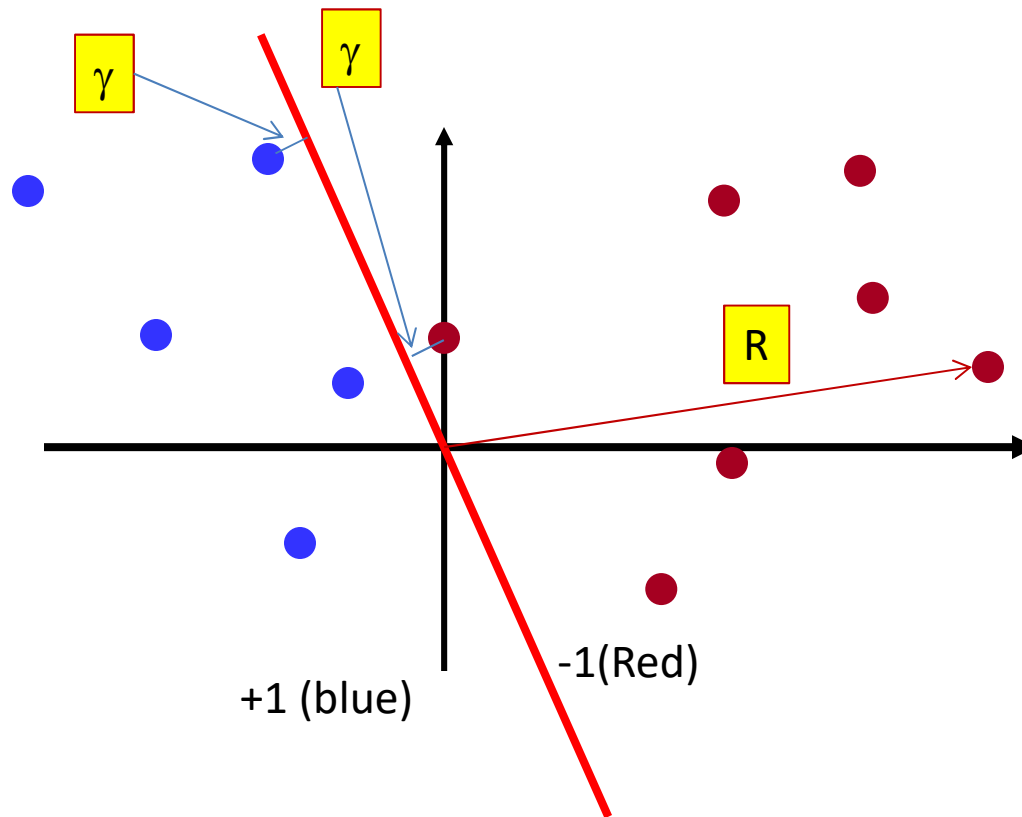

γ is the best-case margin
 R is the length of the longest vector

History: A more complex problem

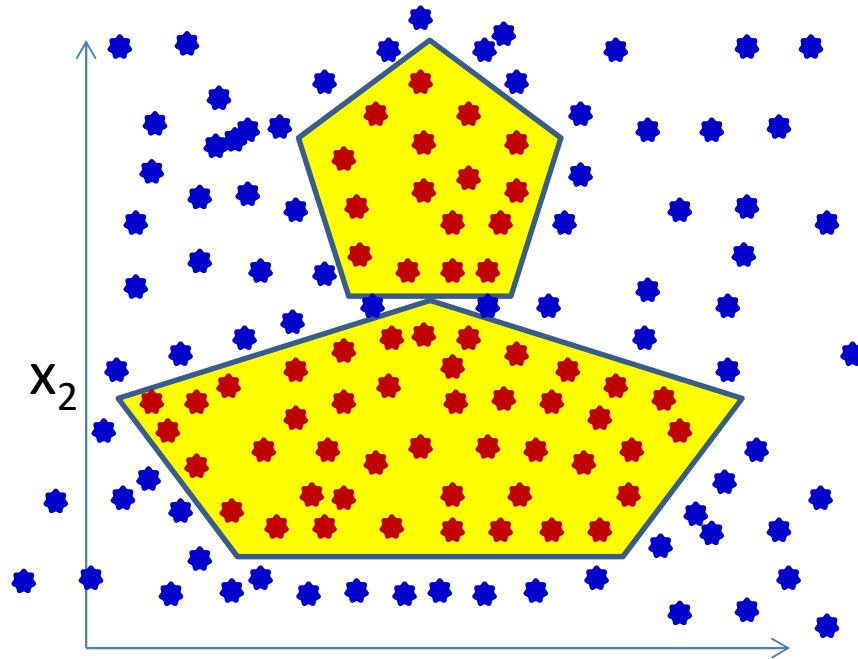
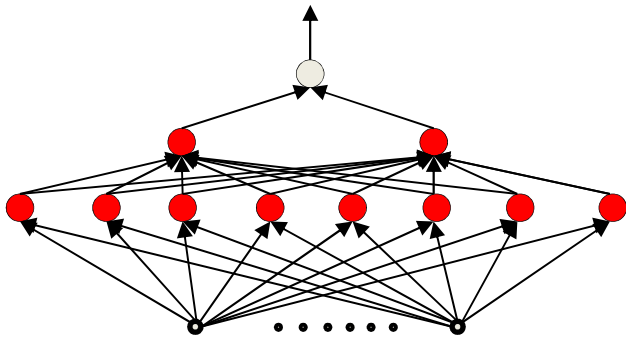

- Learn an *MLP* for this function
 - 1 in the yellow regions, 0 outside
- Using just the samples
- We know this can be perfectly represented using an MLP

More complex decision boundaries

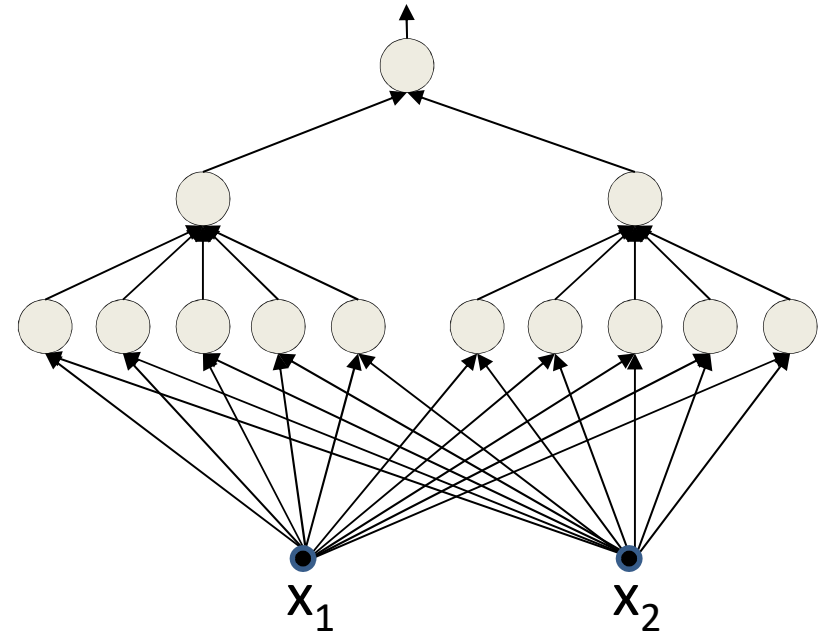
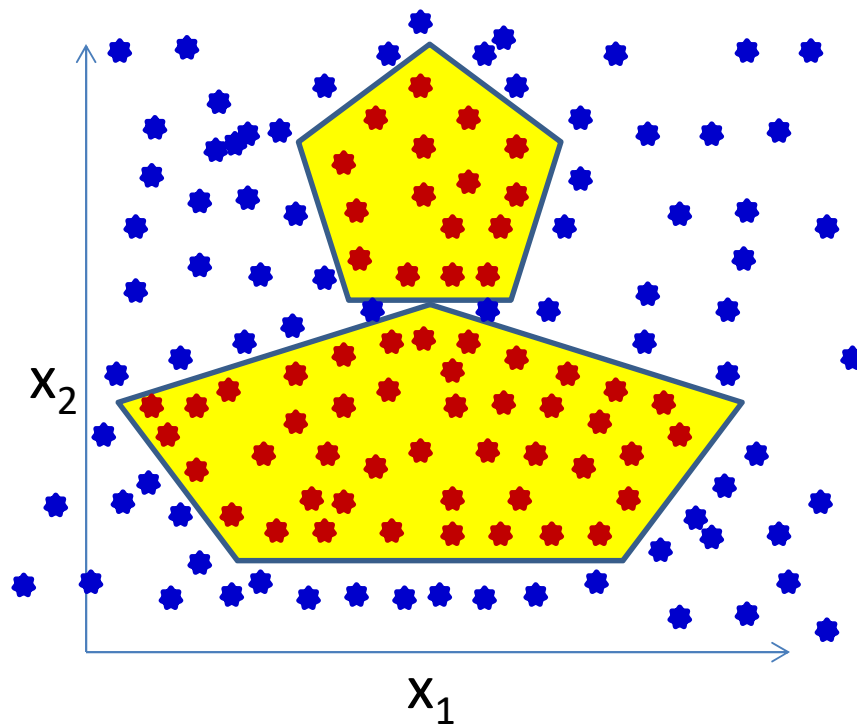

- Even using the perfect architecture
- Can we use the perceptron algorithm?
 - Making incremental corrections every time we encounter an error

The pattern to be learned at the lower level

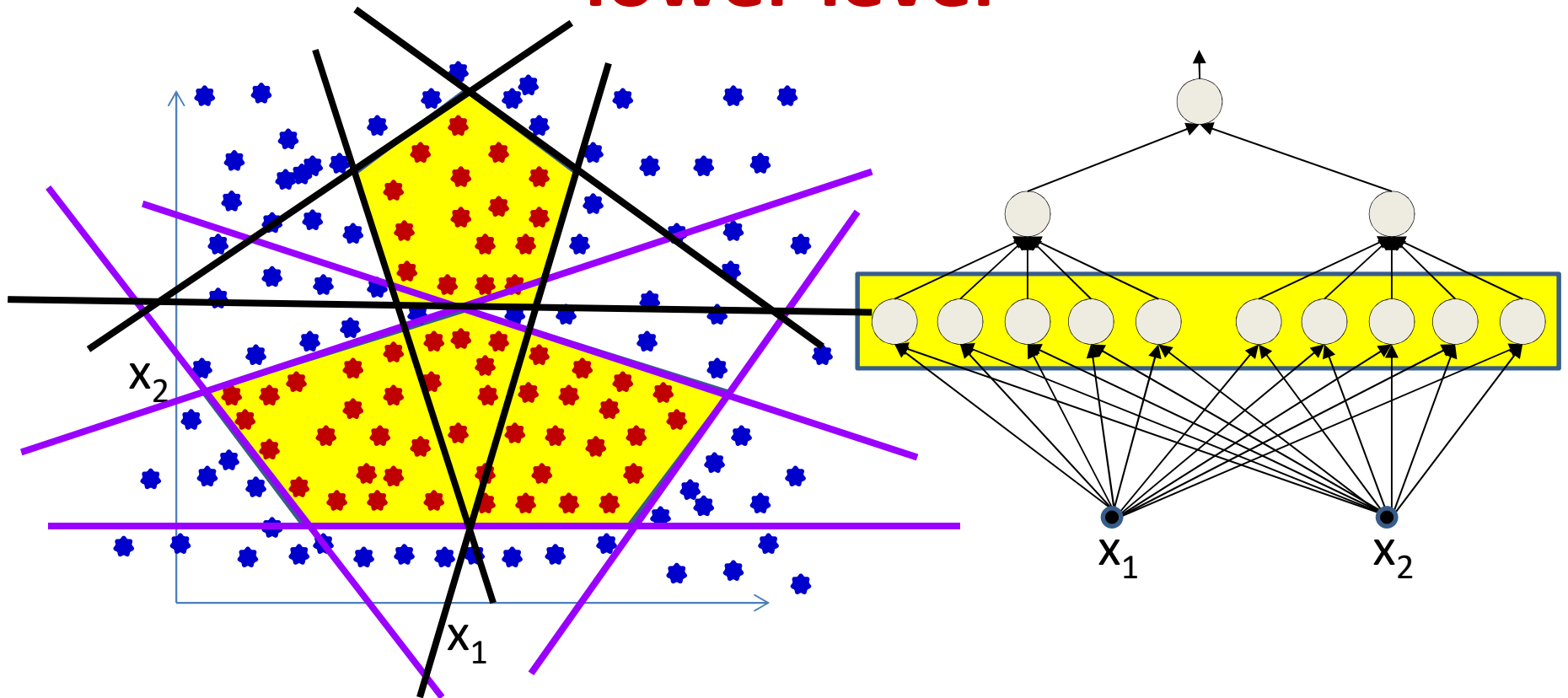

- The lower-level neurons are linear classifiers

The pattern to be learned at the lower level

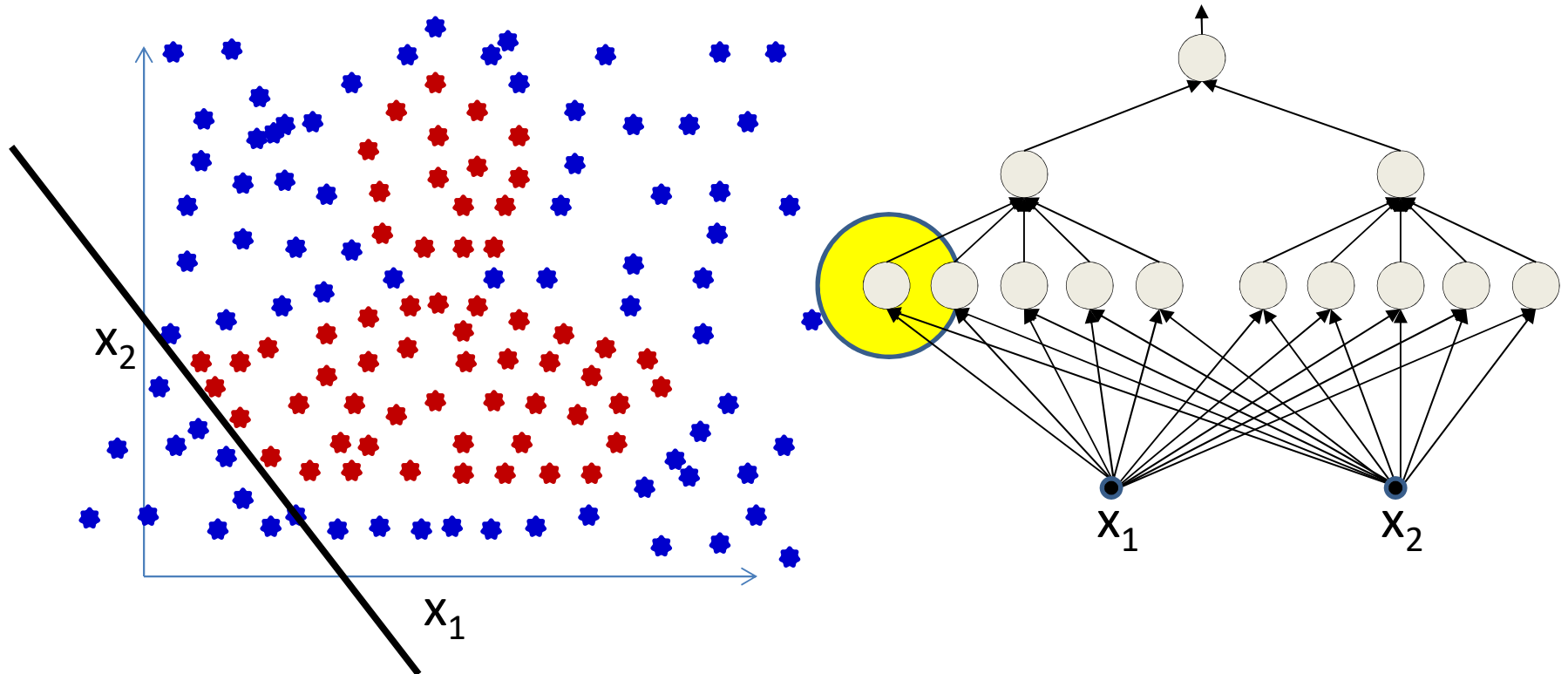

- Consider a single linear classifier that must be learned from the training data
 - Can it be learned from this data?

The pattern to be learned at the lower level

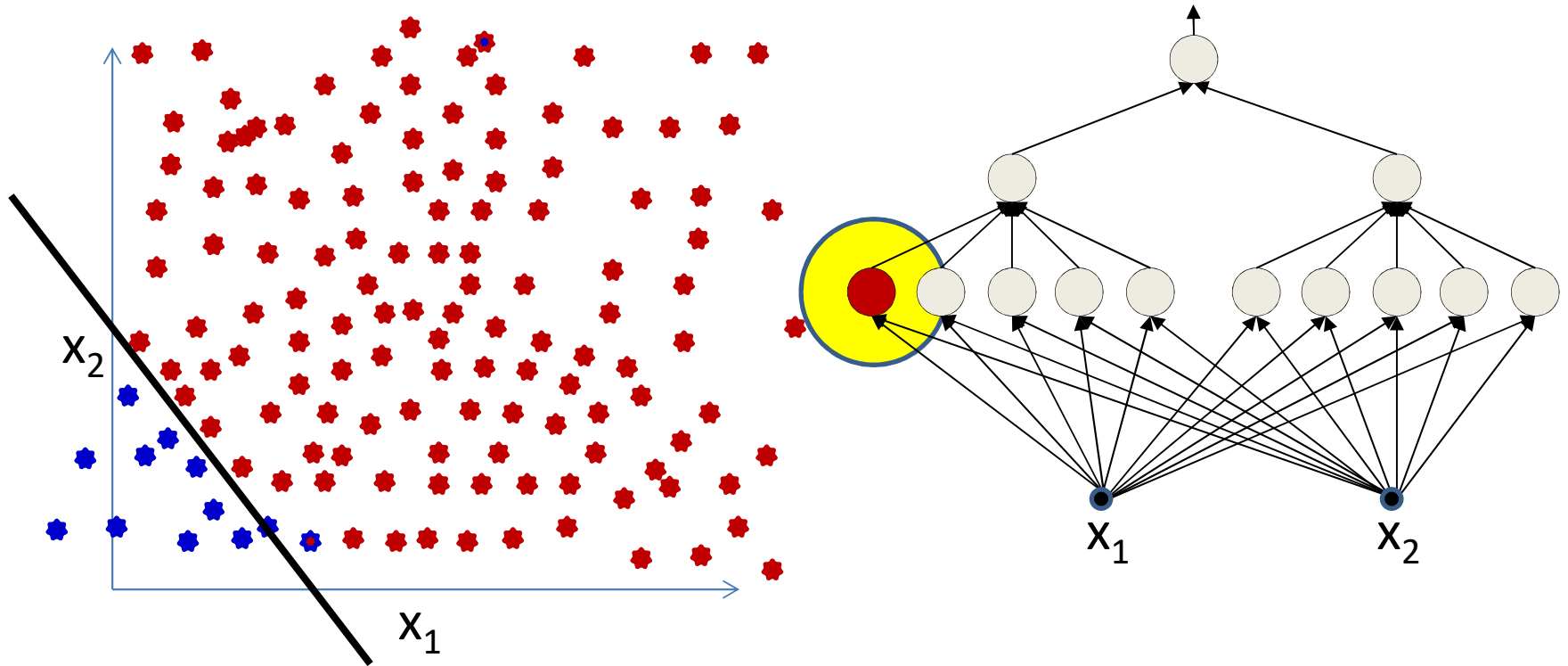

- Consider a single linear classifier that must be learned from the training data
 - Can it be learned from this data?
 - The individual classifier actually requires the kind of labelling shown here
 - Which is *not* given!!

The pattern to be learned at the lower level

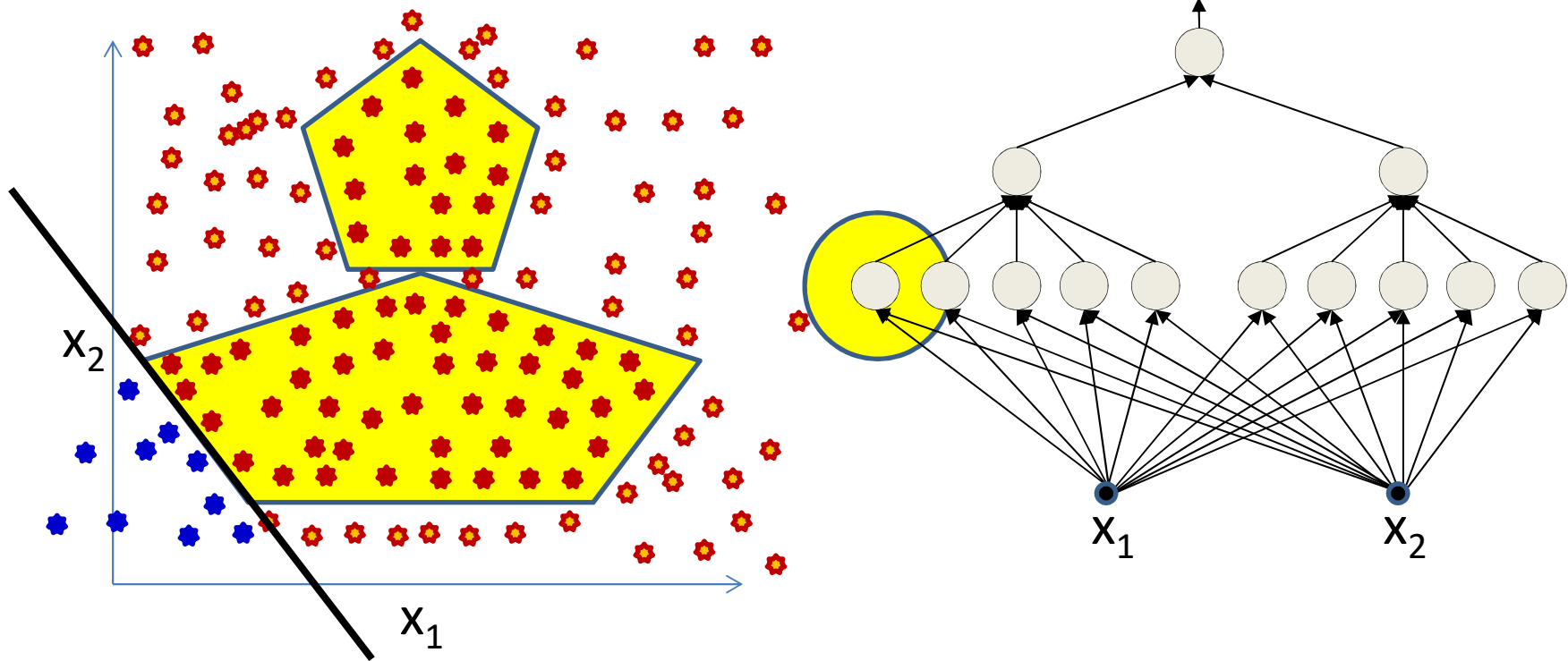

- The lower-level neurons are linear classifiers
 - They require linearly separated labels to be learned
 - The actually provided labels are not linearly separated
 - *Challenge: Must also learn the labels for the lowest units!* ⁵⁷

The pattern to be learned at the lower level

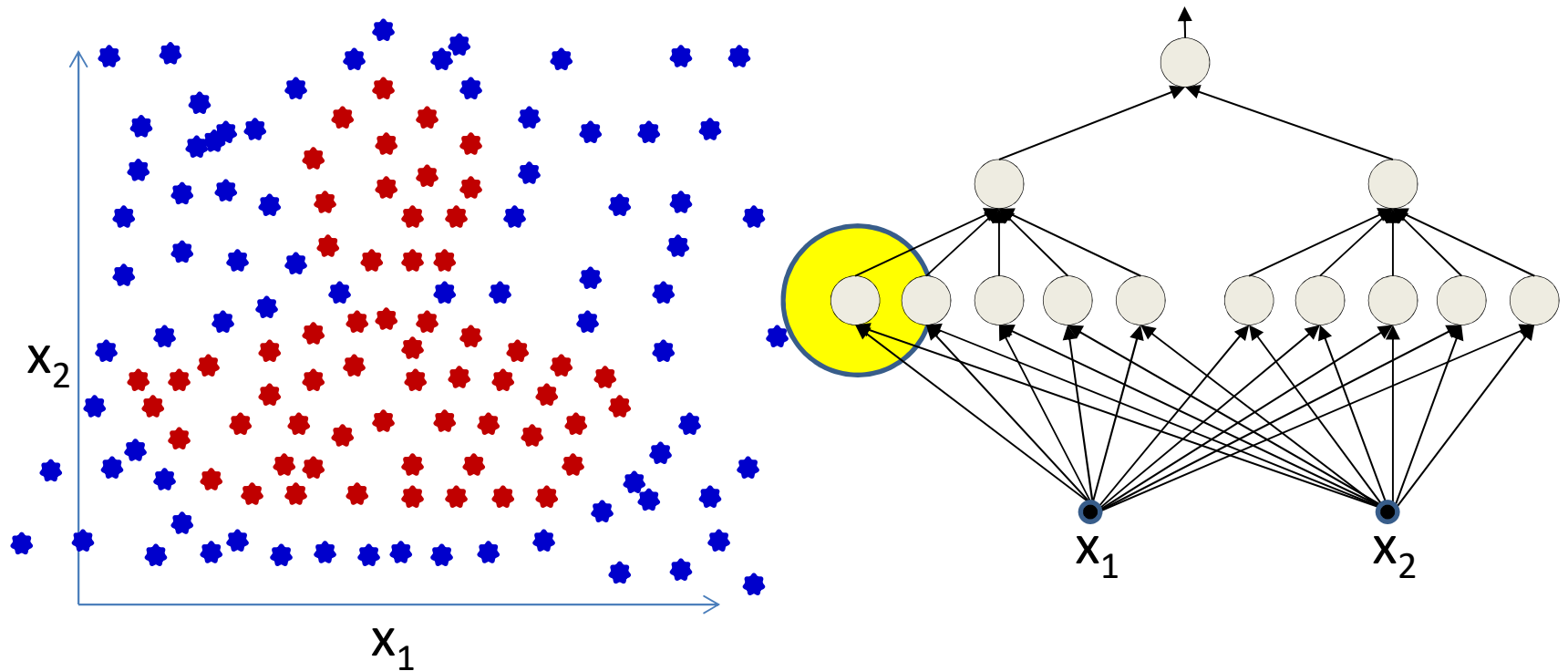

- For a single line:
 - Try out *every possible way of relabeling the blue dots such that we can learn a line that keeps all the red dots on one side!*

The pattern to be learned at the lower level

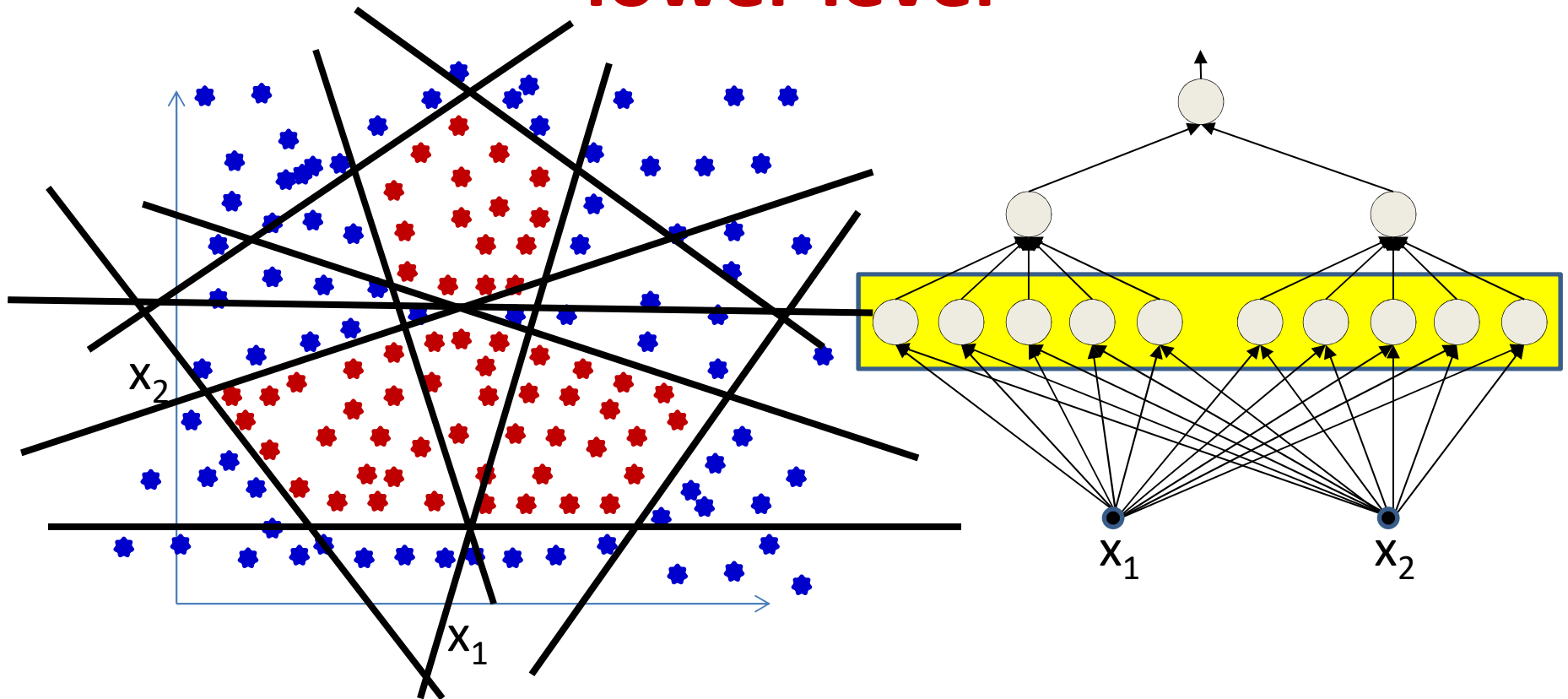

- This must be done for *each* of the lines (perceptrons)
- Such that, when all of them are combined by the higher-level perceptrons we get the desired pattern
 - Basically an exponential search over inputs

Individual neurons represent one of the lines that compose the figure (linear classifiers)

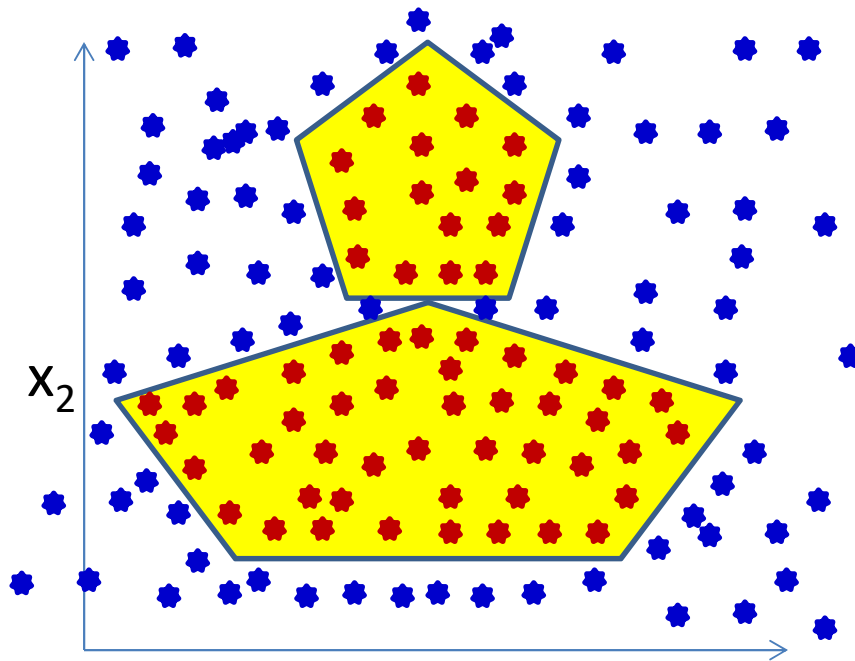

Must know the output of every neuron for every training instance, in order to learn this neuron

The outputs should be such that the neuron individually has a linearly separable task

The linear separators must combine to form the desired boundary

This must be done for every neuron

Getting any of them wrong will result in incorrect output!

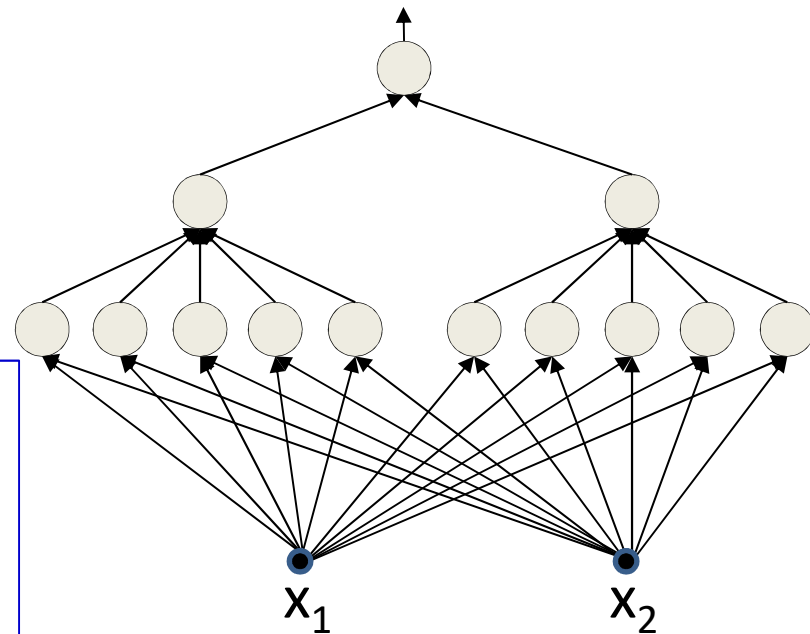

Learning a *multilayer* perceptron

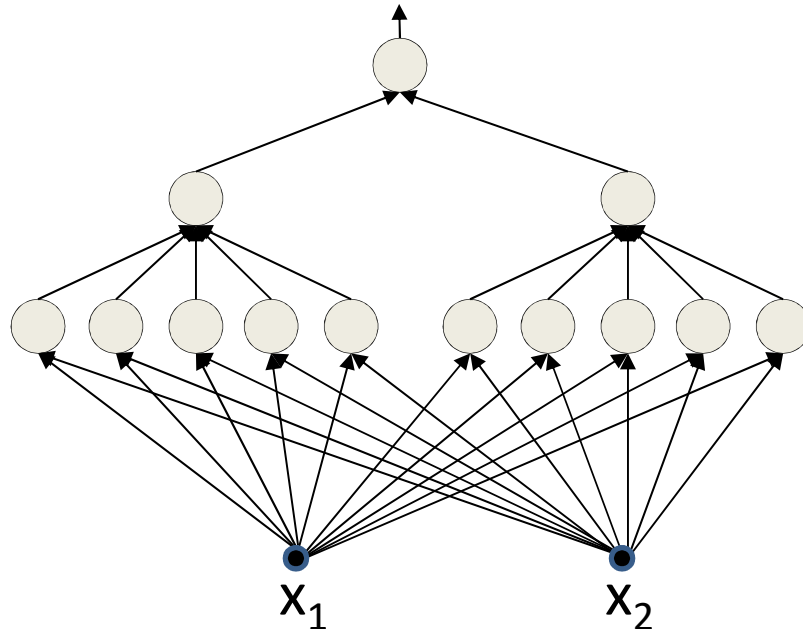

Training data only specifies
input and output of network

Intermediate outputs (outputs
of individual neurons) are not specified

- Training this network using the perceptron rule is a combinatorial optimization problems
- We don't know the outputs of the individual intermediate neurons in the network for any training input
- **Must also determine the correct output for *each* neuron for *every* training instance**
- **NP! Exponential time complexity**

Greedy algorithms: Adaline and Madaline

- The perceptron learning algorithm cannot directly be used to learn an MLP
 - Exponential complexity of assigning intermediate labels
 - Even worse when classes are not actually separable
- Can we use a *greedy* algorithm instead?
 - Adaline / Madaline
 - On slides, will skip in class (check the quiz)

A little bit of History: Widrow



Bernie Widrow

- Scientist, Professor, Entrepreneur
 - Inventor of most useful things in signal processing and machine learning!
-
- First known attempt at an analytical solution to training the perceptron and the MLP
 - Now famous as the LMS algorithm
 - Used everywhere
 - Also known as the “delta rule”

History: ADALINE

$$z = \sum_t w_i x_i$$

Using 1-extended vector notation to account for bias

$$y = \begin{cases} 0, & z < 0 \\ 1, & z \geq 0 \end{cases}$$

- Adaptive *linear* element (Hopf and Widrow, 1960)
- Actually just a regular perceptron
 - Weighted sum on inputs and bias passed through a thresholding function
- ADALINE differs in the *learning rule*

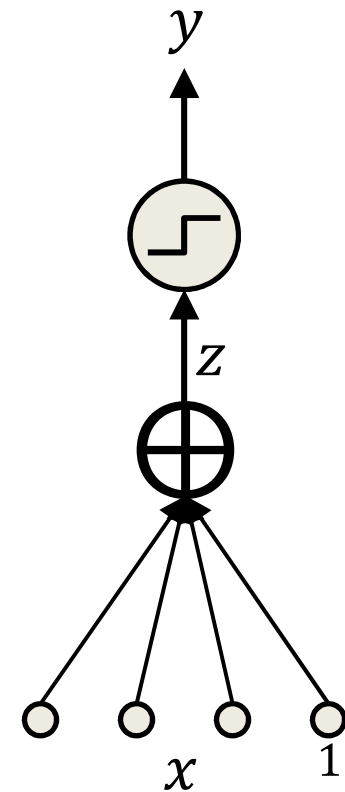

History: Learning in ADALINE

$$z = \sum_t w_i x_i$$

$$out = \begin{cases} 0, & z < 0 \\ 1, & z \geq 0 \end{cases}$$

- During learning, minimize the squared error assuming z to be real output
- The desired output is still binary!

$$Err(x) = \frac{1}{2} (d - z)^2$$

Error for a single input

$$\frac{dErr(x)}{dw_i} = -(d - z)x_i$$

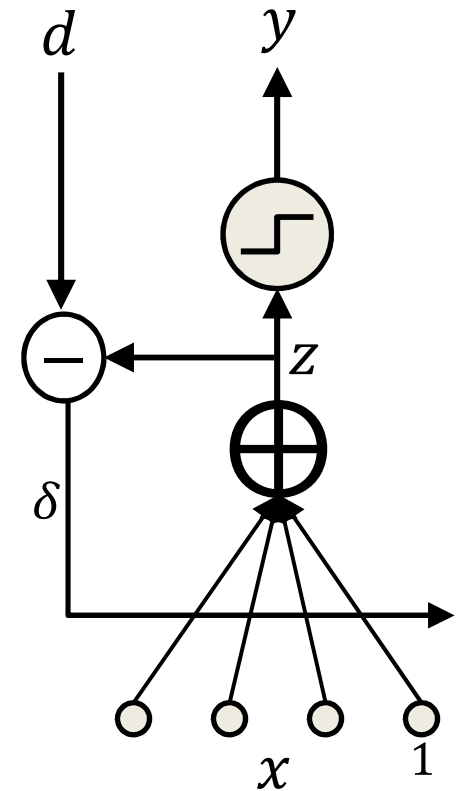

History: Learning in ADALINE

$$z = \sum_t w_i x_i$$

$$Err(x) = \frac{1}{2} (d - z)^2$$

Error for a single input

$$\frac{dErr(x)}{dw_i} = -(d - z)x_i$$

- If we just have a single training input, the *gradient descent* update rule is

$$w_i = w_i + \eta(d - z)x_i$$

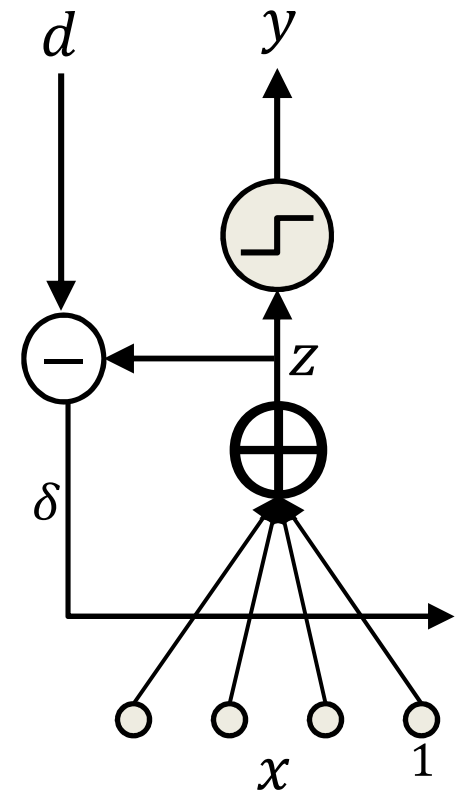

The ADALINE learning rule

- Online learning rule
- **After each input \mathbf{x}** , that has target (binary) output d , compute and update:

$$\delta = d - z$$

$$w_i = w_i + \eta \delta x_i$$

- This is the famous *delta rule*
 - Also called the LMS update rule

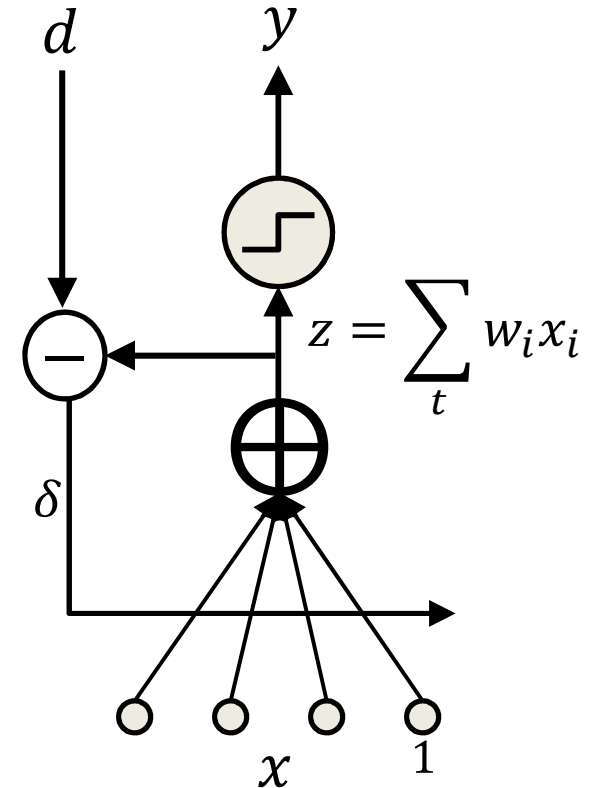

The Delta Rule

- In fact both the Perceptron and ADALINE use variants of the delta rule!

- Perceptron: Output used in delta rule is y

$$\delta = d - y$$

- ADALINE: Output used to estimate weights is z

$$\delta = d - z$$

- For both

$$w_i = w_i + \eta \delta x_i$$

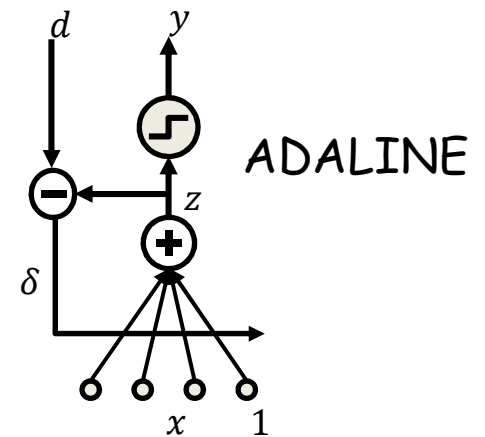
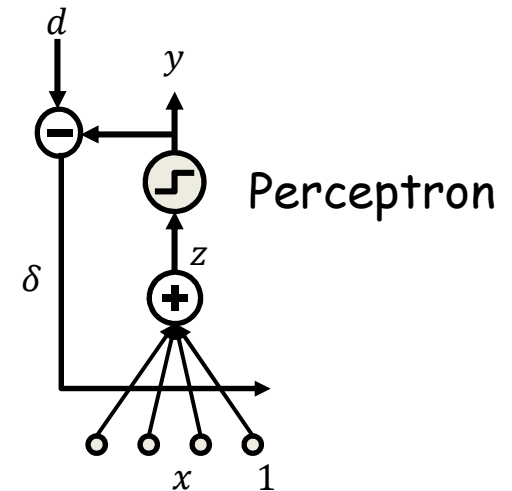

Aside: Generalized delta rule

- For any differentiable activation function the following update rule is used

$$\delta = d - y$$

$$w_i = w_i + \eta \delta f'(z) x_i$$

- This is the famous Widrow-Hoff update rule
 - Lookahead: Note that this is *exactly* backpropagation in multilayer nets if we let $f(z)$ represent the entire network between z and y
- It is possibly the most-used update rule in machine learning and signal processing
 - Variants of it appear in almost every problem

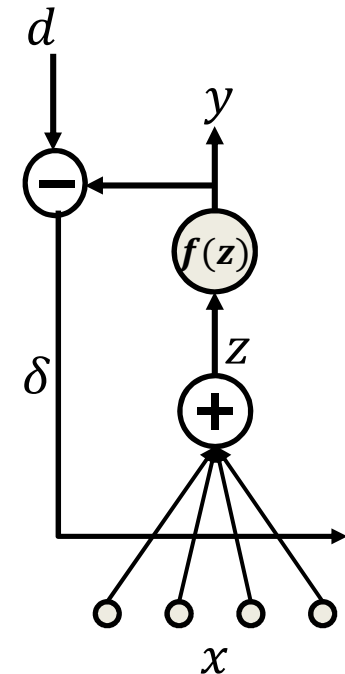

Multilayer perceptron: MADALINE

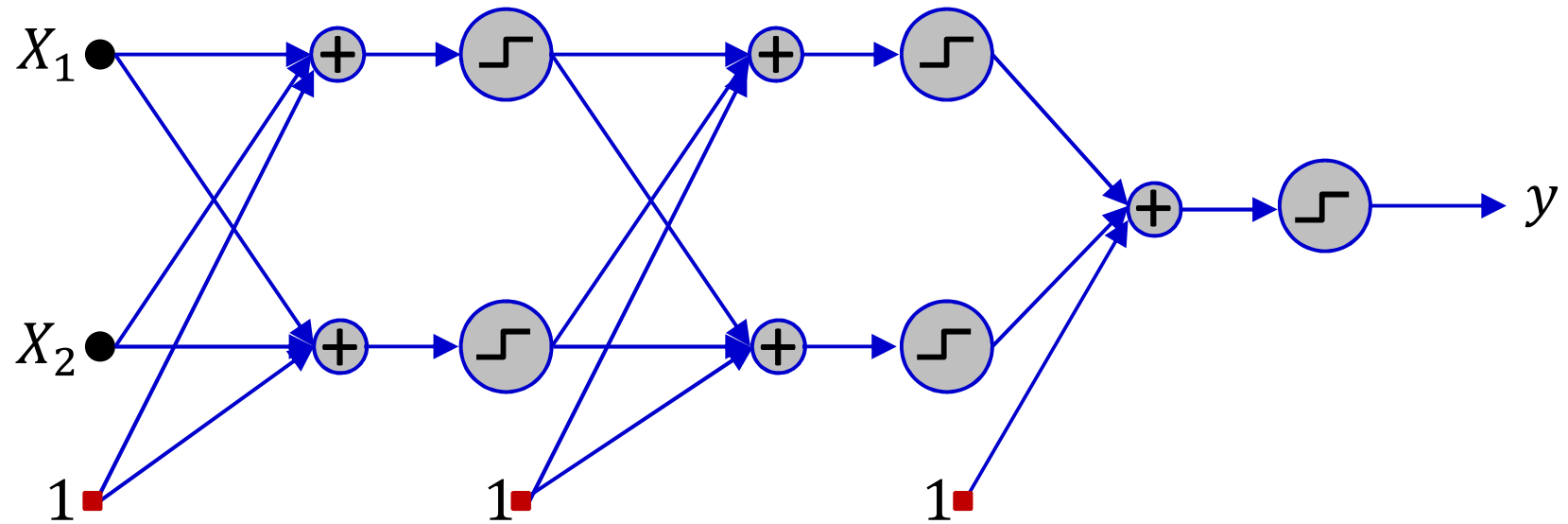

- *Multiple Adaline*
 - A multilayer perceptron with threshold activations
 - The MADALINE

MADALINE Training

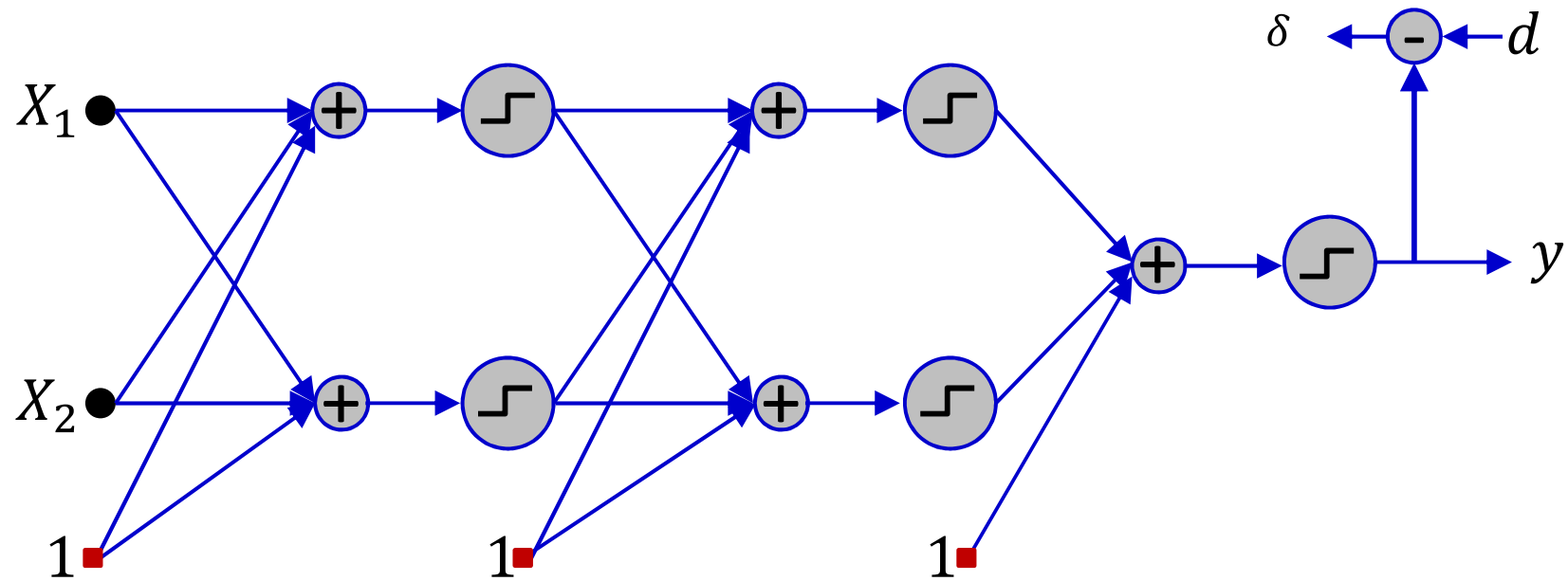

- *Update only on error*
 - $\delta \neq 0$
 - On inputs for which output and target values differ

MADALINE Training

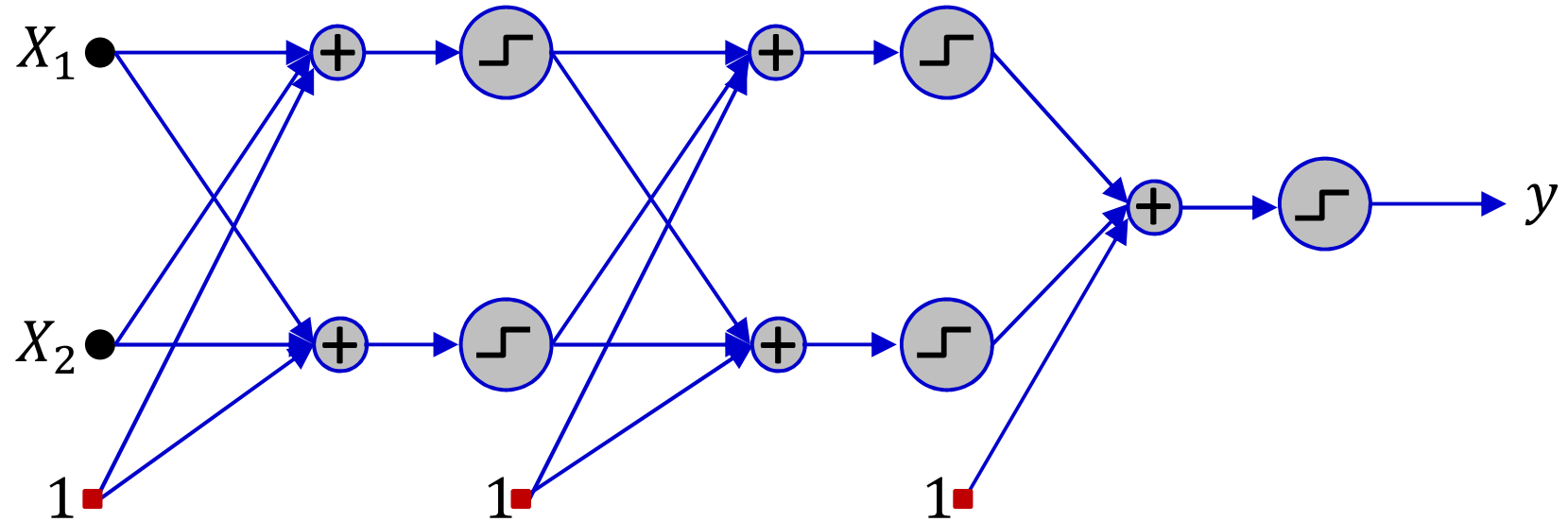

- While stopping criterion not met do:
 - Classify an input

MADALINE Training

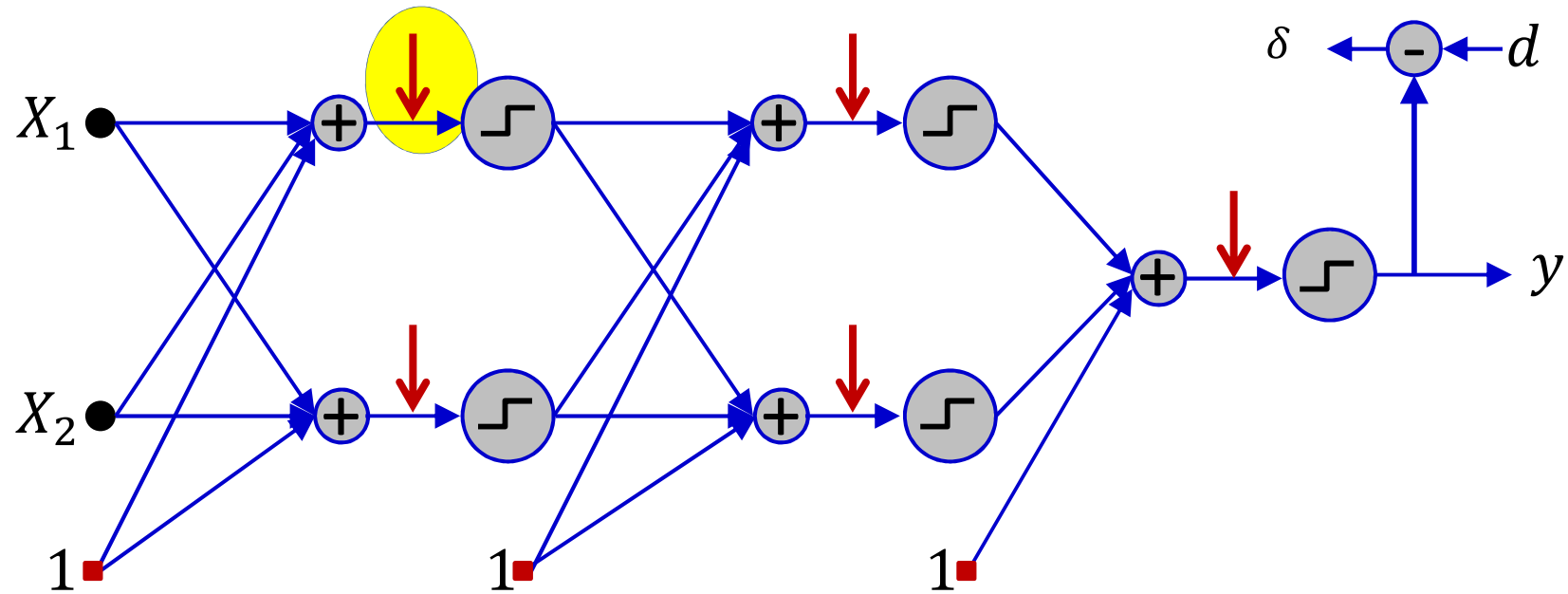

- While stopping criterion not met do:
 - Classify an input
 - If error, find the z that is closest to 0

MADALINE Training

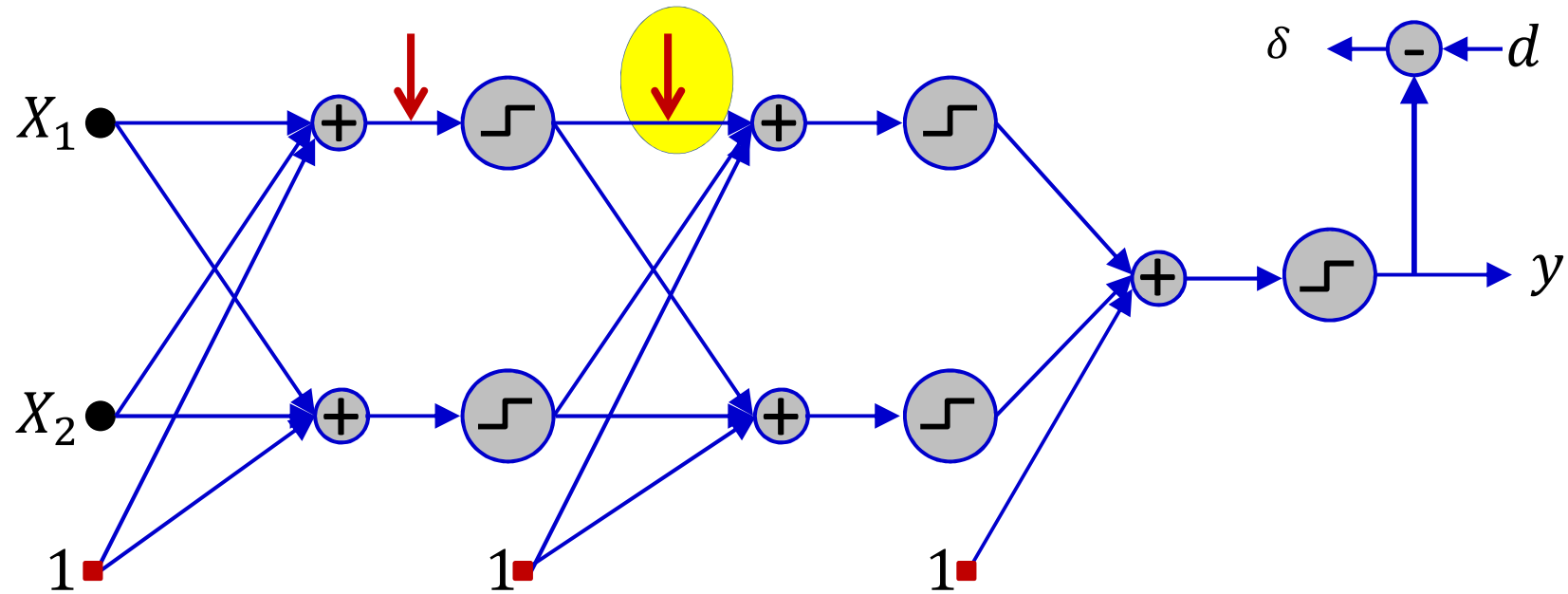

- While stopping criterion not met do:
 - Classify an input
 - If error, find the z that is closest to 0
 - Flip the output of corresponding unit and compute new output

MADALINE Training

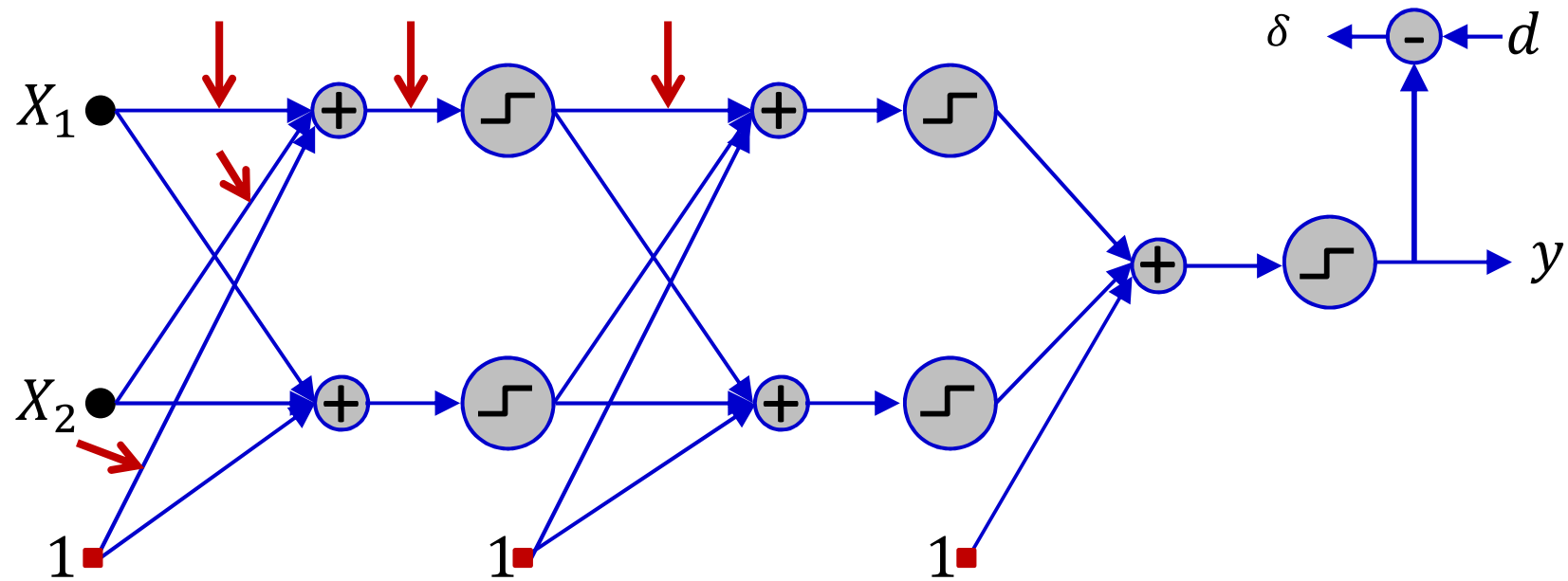

- While stopping criterion not met do:
 - Classify an input
 - If error, find the z that is closest to 0
 - Flip the output of corresponding unit and compute new output
 - If error reduces:
 - Set the desired output of the unit to the flipped value
 - Apply ADALINE rule to update weights of the unit

MADALINE

- Greedy algorithm, effective for small networks
- Not very useful for large nets
 - Too expensive
 - Too greedy

Story so far

- “Learning” a network = learning the weights and biases to compute a target function
 - Will require a network with sufficient “capacity”
- In practice, we learn networks by “fitting” them to match the input-output relation of “training” instances drawn from the target function
- A linear decision boundary can be learned by a single perceptron (with a threshold-function activation) in linear time if classes are linearly separable
- Non-linear decision boundaries require networks of perceptrons
- Training an MLP with threshold-function activation perceptrons will require knowledge of the input-output relation for every training instance, for *every* perceptron in the network
 - These must be determined as part of training
 - For threshold activations, this is an NP-complete combinatorial optimization problem

History..

- The realization that training an entire MLP was a combinatorial optimization problem stalled development of neural networks for well over a decade!

Why this problem?

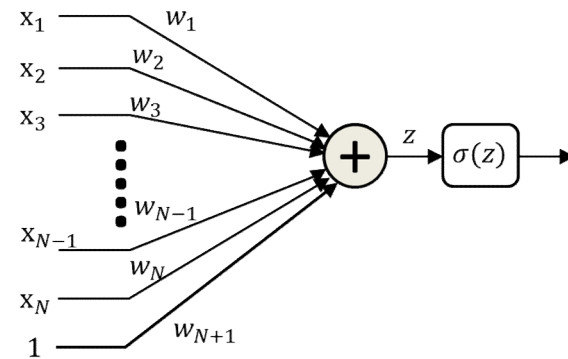
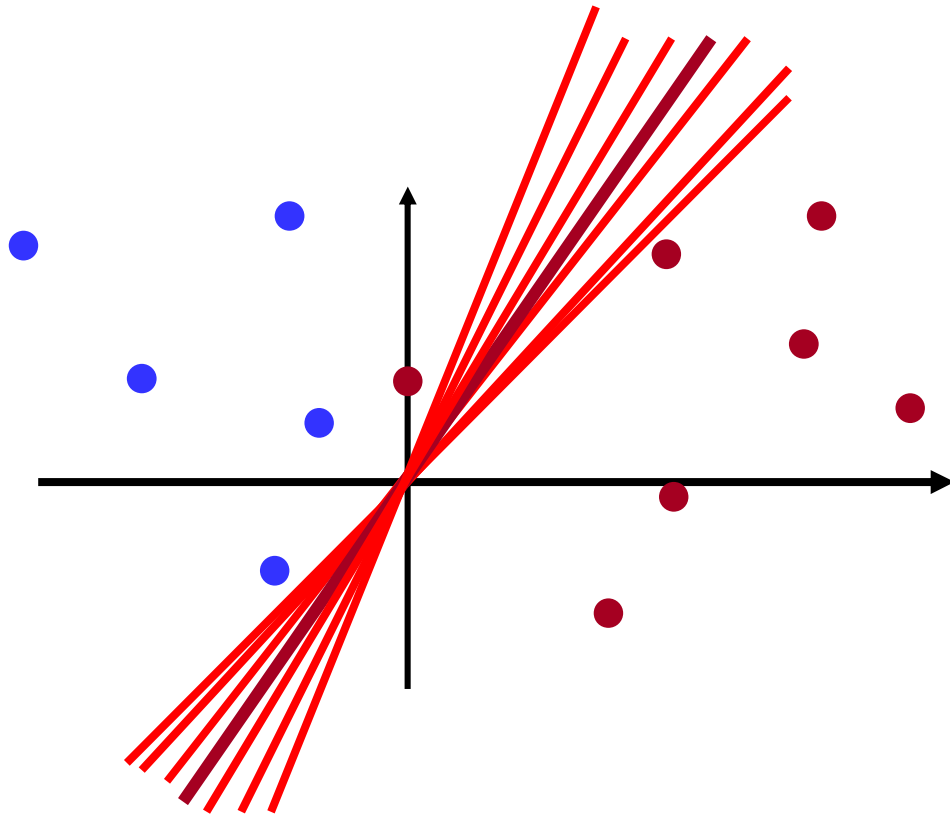

$$\sigma(z) = \begin{array}{|c|c|} \hline & \\ \hline \end{array}$$

- The perceptron is a flat function with zero derivative everywhere, except at 0 where it is non-differentiable
 - You can vary the weights a *lot* without changing the error
 - There is no indication of which direction to change the weights to reduce error

This only compounds on larger problems

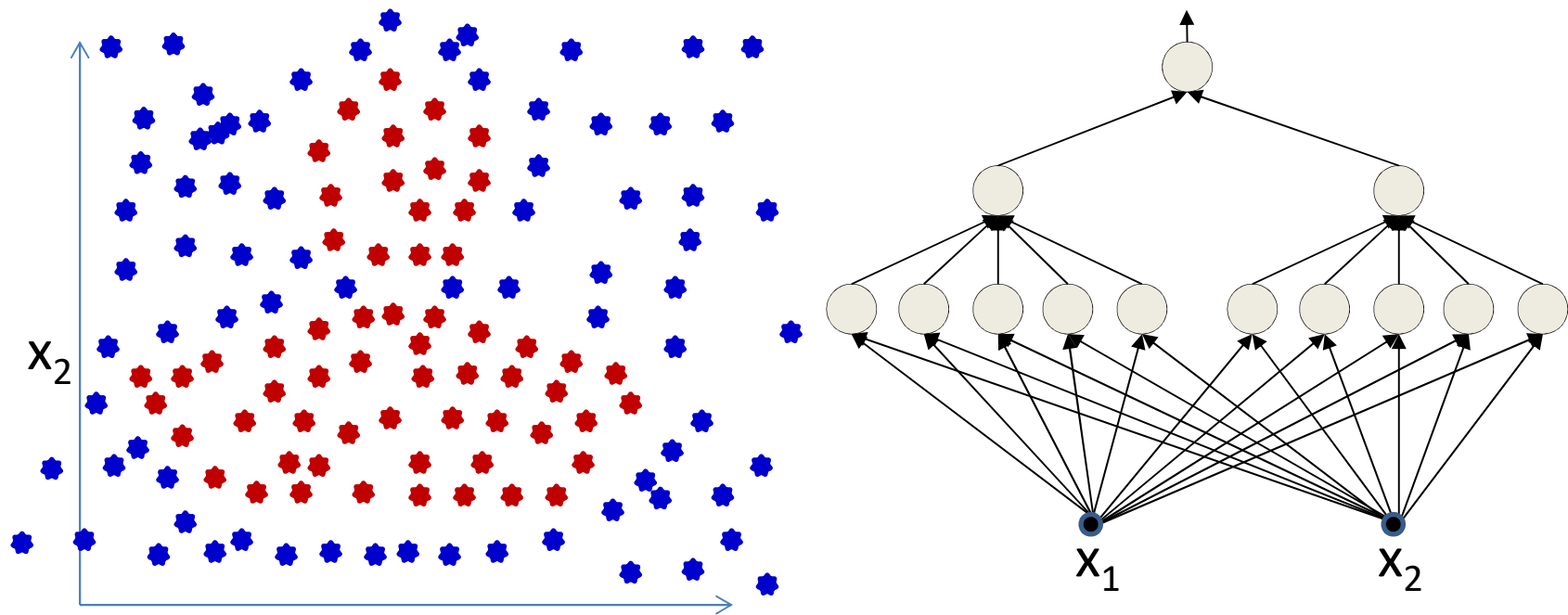

- Individual neurons' weights can change significantly without changing overall error
- The simple MLP is a flat, non-differentiable function
 - Actually a function with 0 derivative nearly everywhere, and no derivatives at the boundaries

A second problem: What we *actually* model

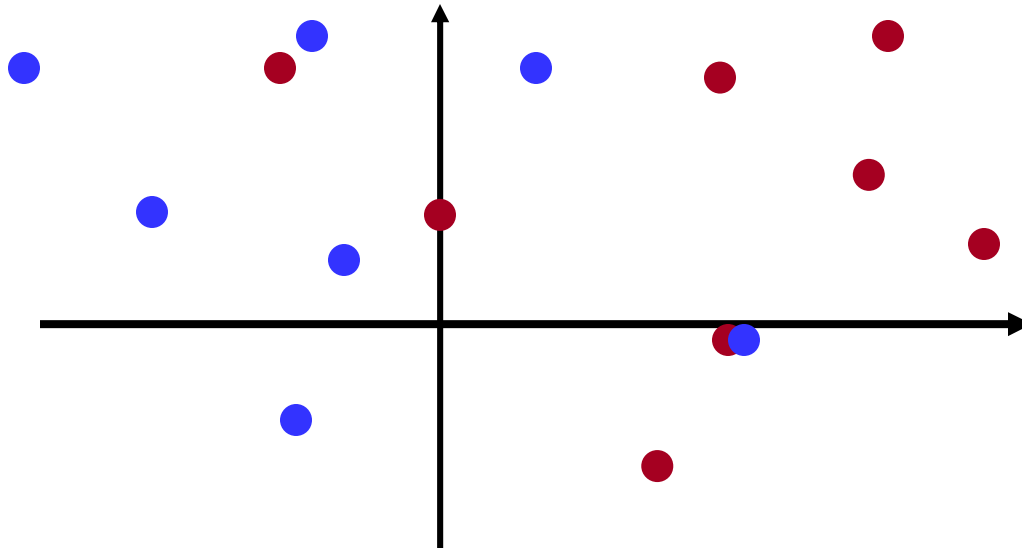

- Real-life data are rarely clean
 - Not linearly separable
 - Rosenblatt's perceptron wouldn't work in the first place

Solution

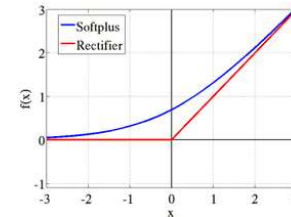
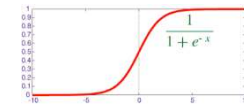
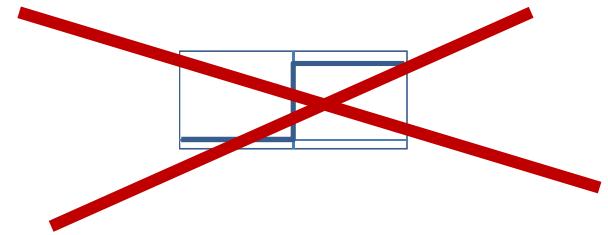
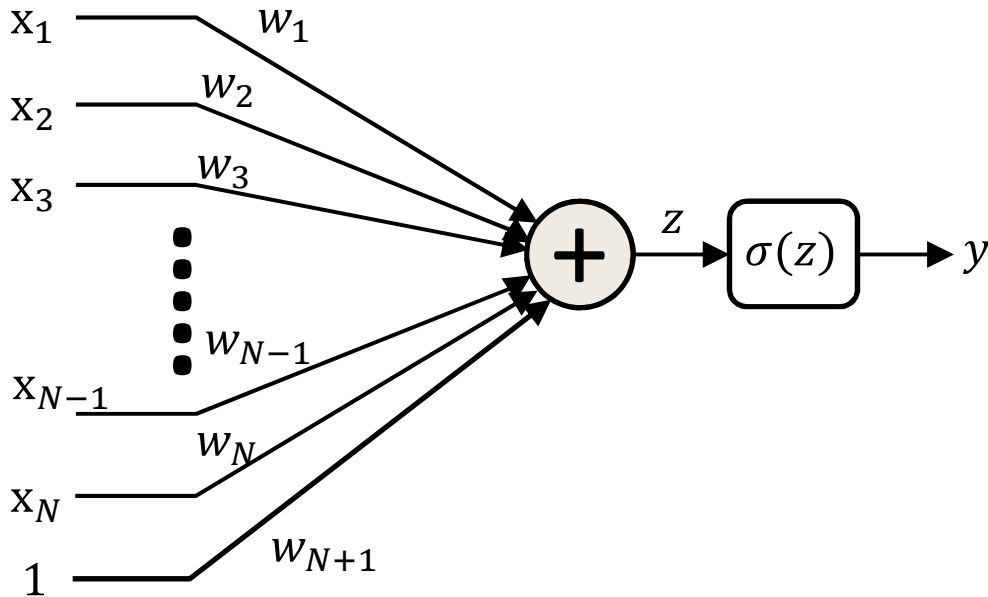

Activation functions $\sigma(z)$

- Lets make the neuron differentiable, *with non-zero derivatives over much of the input space*
 - Small changes in weight can result in non-negligible changes in output
 - This enables us to estimate the parameters using gradient descent techniques..

Differentiable Activations: An aside

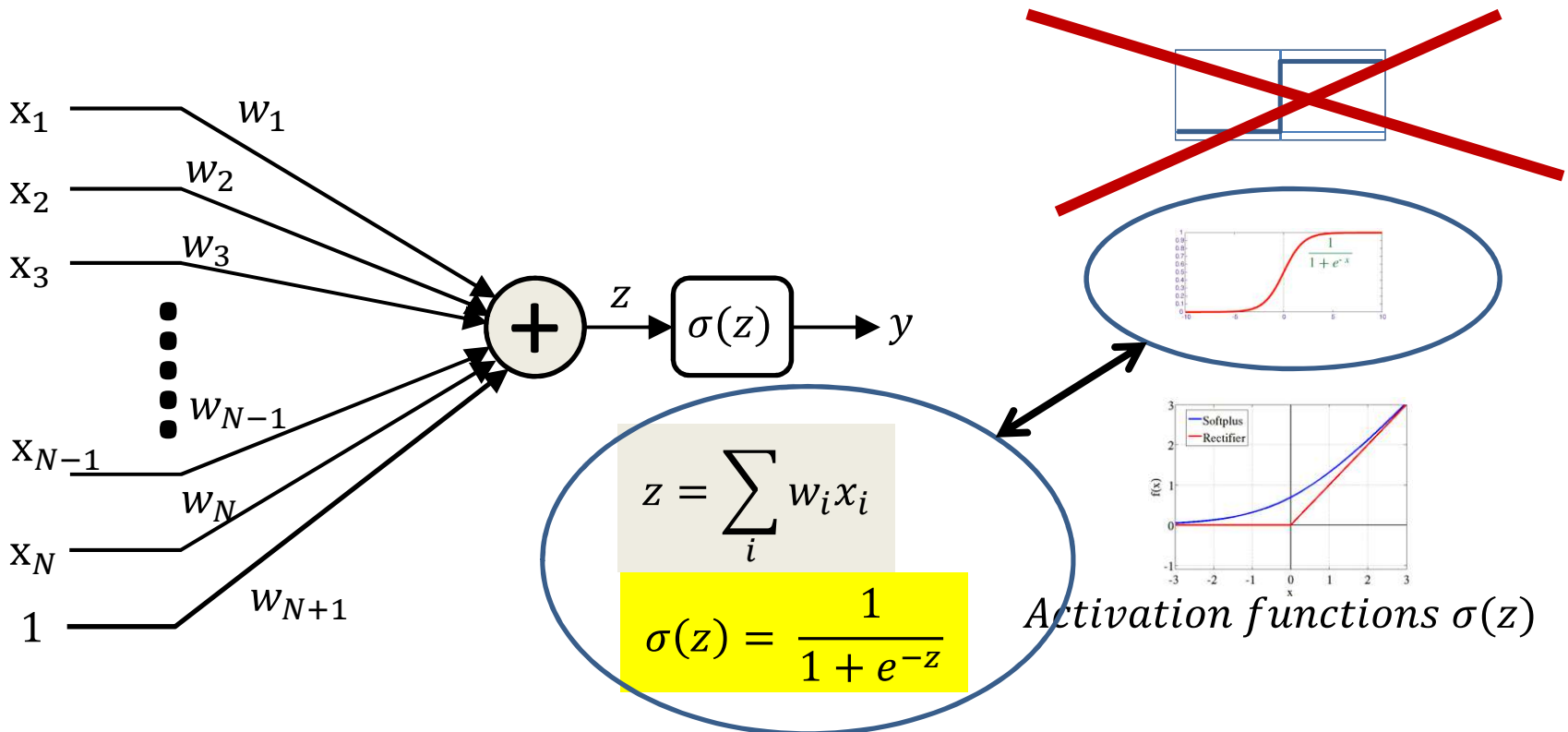

- This particular one has a nice interpretation

Non-linearly separable data

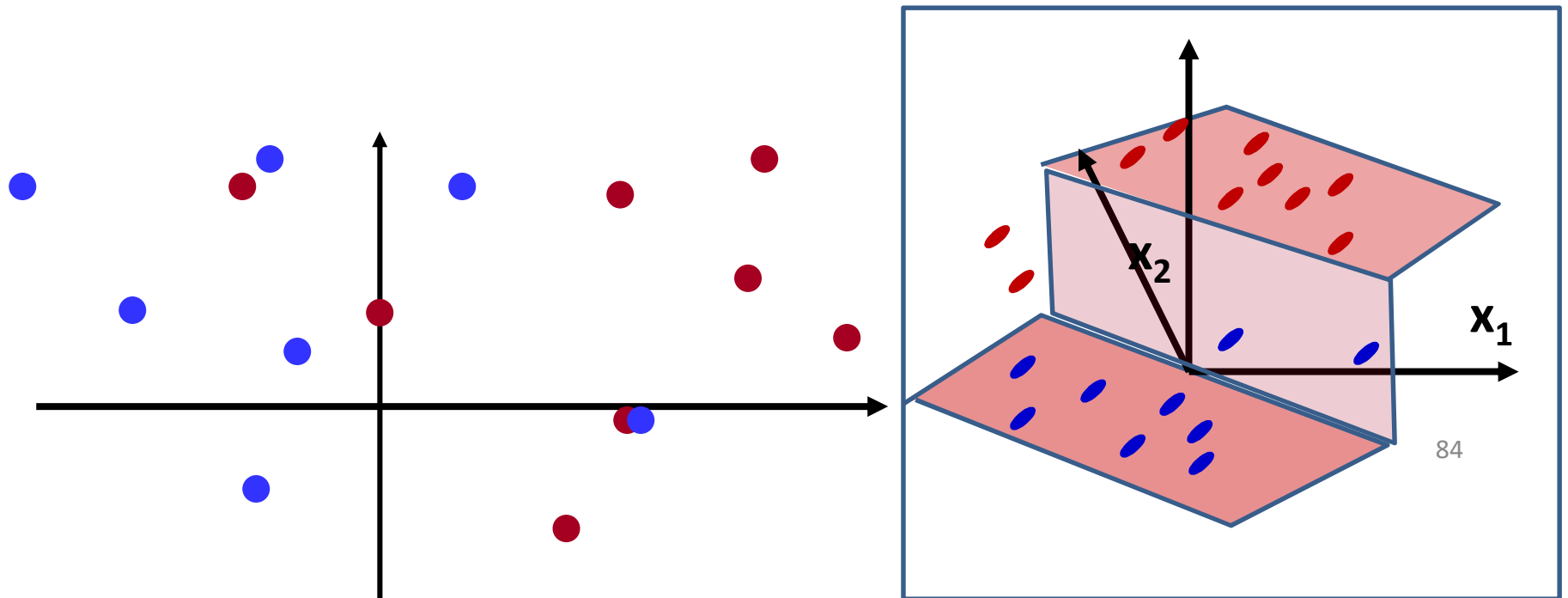

- Two-dimensional example
 - Blue dots (on the floor) on the “red” side
 - Red dots (suspended at $Y=1$) on the “blue” side
 - No line will cleanly separate the two colors

Non-linearly separable data: 1-D example

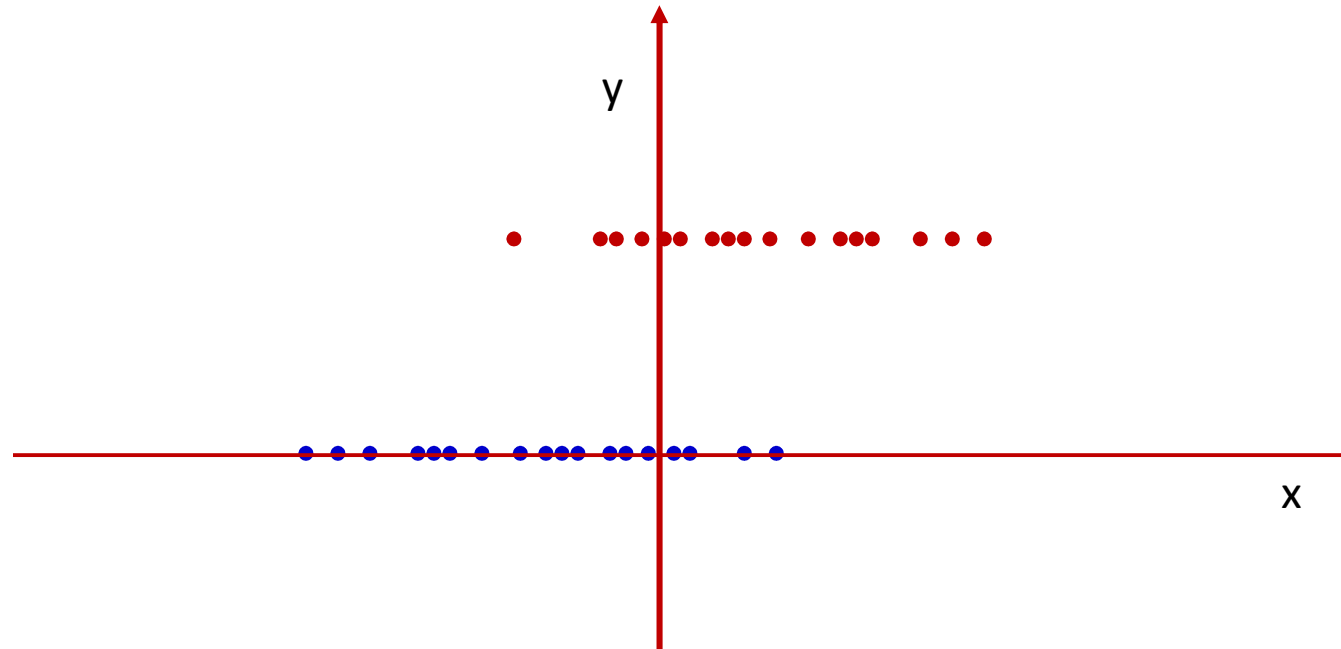

- One-dimensional example for visualization
 - All (red) dots at $Y=1$ represent instances of class $Y=1$
 - All (blue) dots at $Y=0$ are from class $Y=0$
 - The data are not linearly separable
 - In this 1-D example, a linear separator is a threshold
 - No threshold will cleanly separate red and blue dots

The *probability* of $y=1$

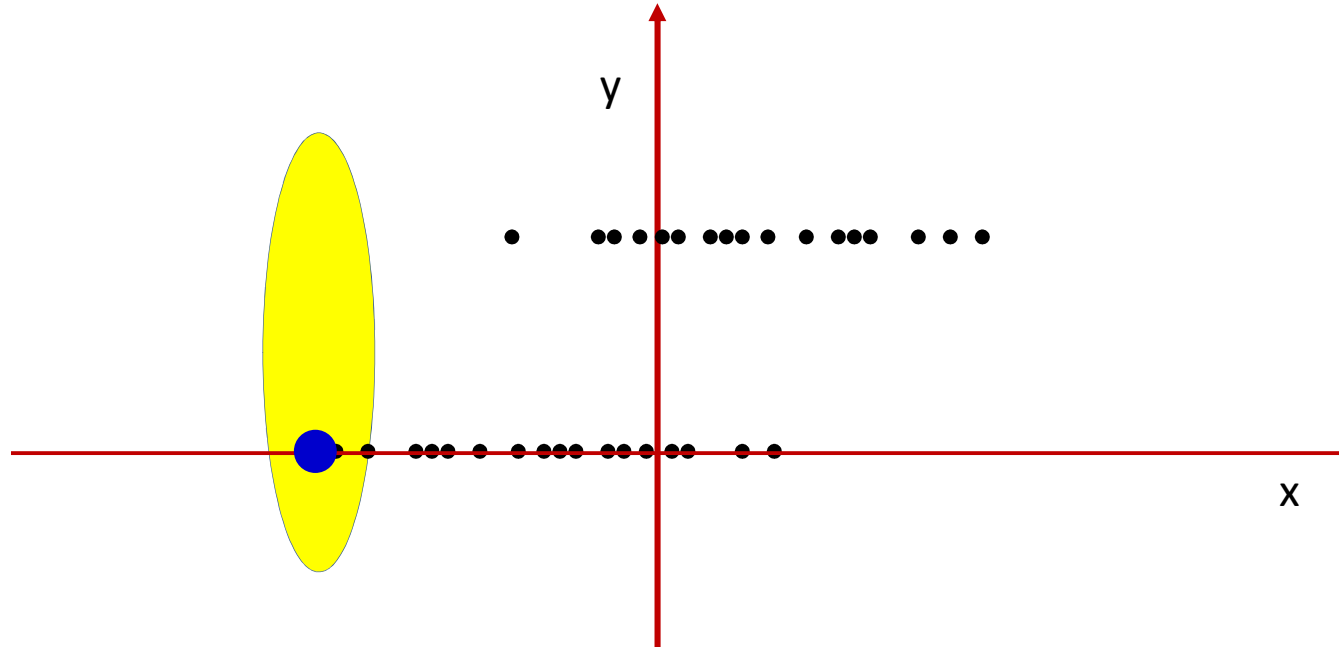

- Consider this differently: at each point look at a small window around that point
- Plot the average value within the window
 - This is an approximation of the *probability* of $Y=1$ at that point

The *probability* of $y=1$

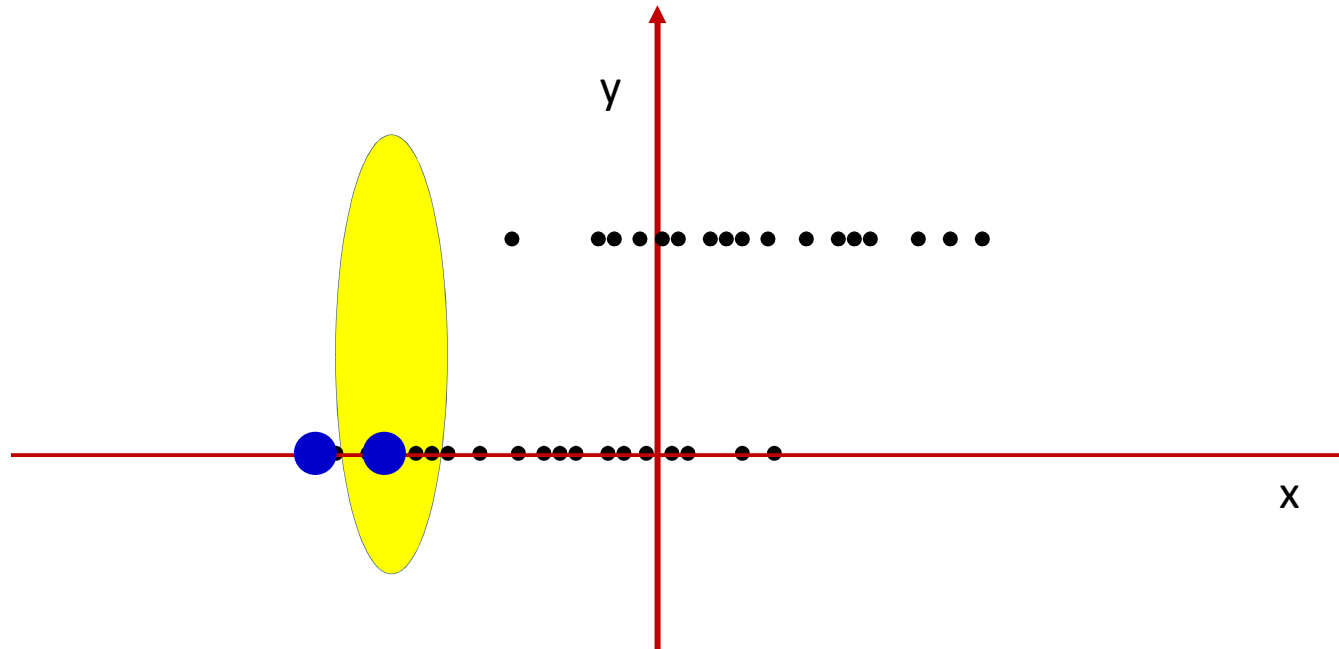

- Consider this differently: at each point look at a small window around that point
- Plot the average value within the window
 - This is an approximation of the *probability* of 1 at that point

The *probability* of $y=1$

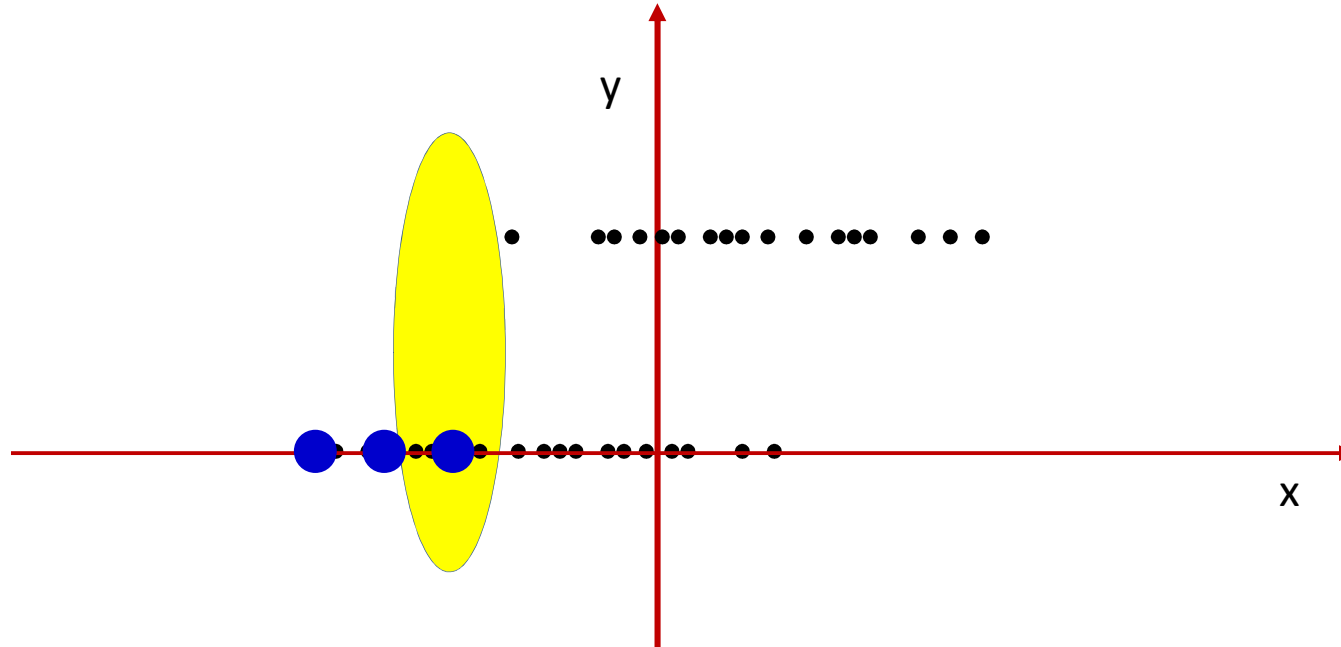

- Consider this differently: at each point look at a small window around that point
- Plot the average value within the window
 - This is an approximation of the *probability* of 1 at that point

The *probability* of $y=1$

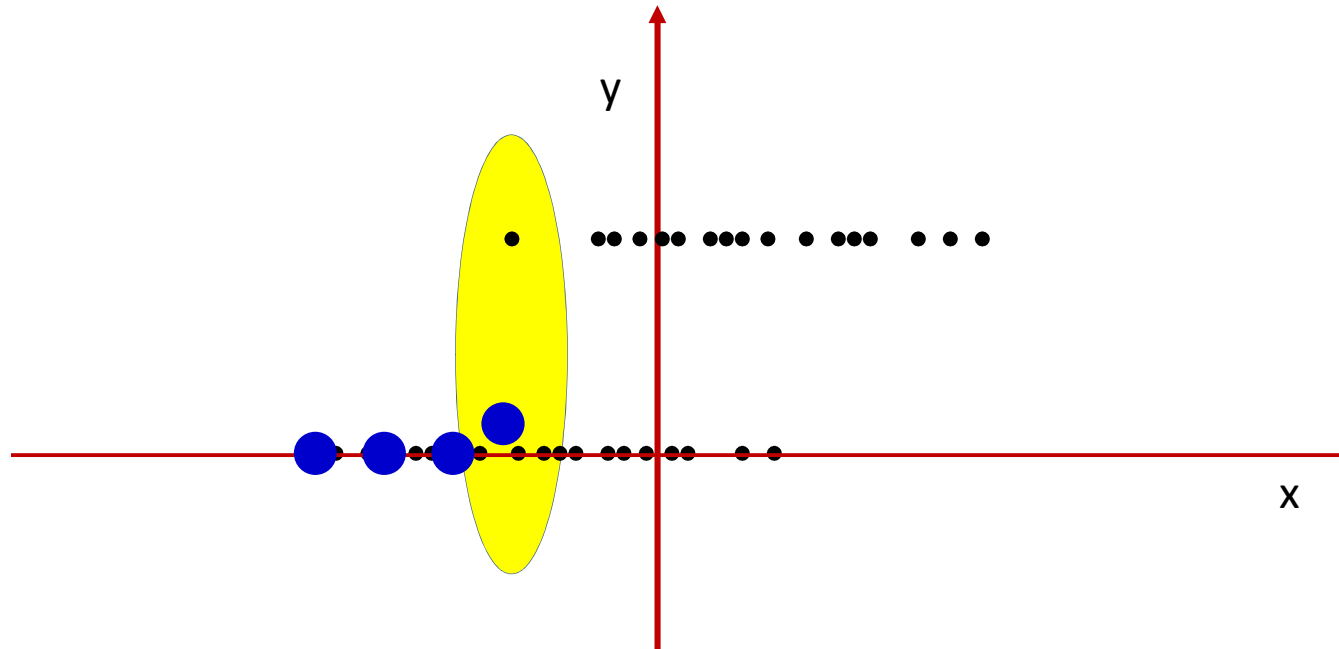

- Consider this differently: at each point look at a small window around that point
- Plot the average value within the window
 - This is an approximation of the *probability* of 1 at that point

The *probability* of $y=1$

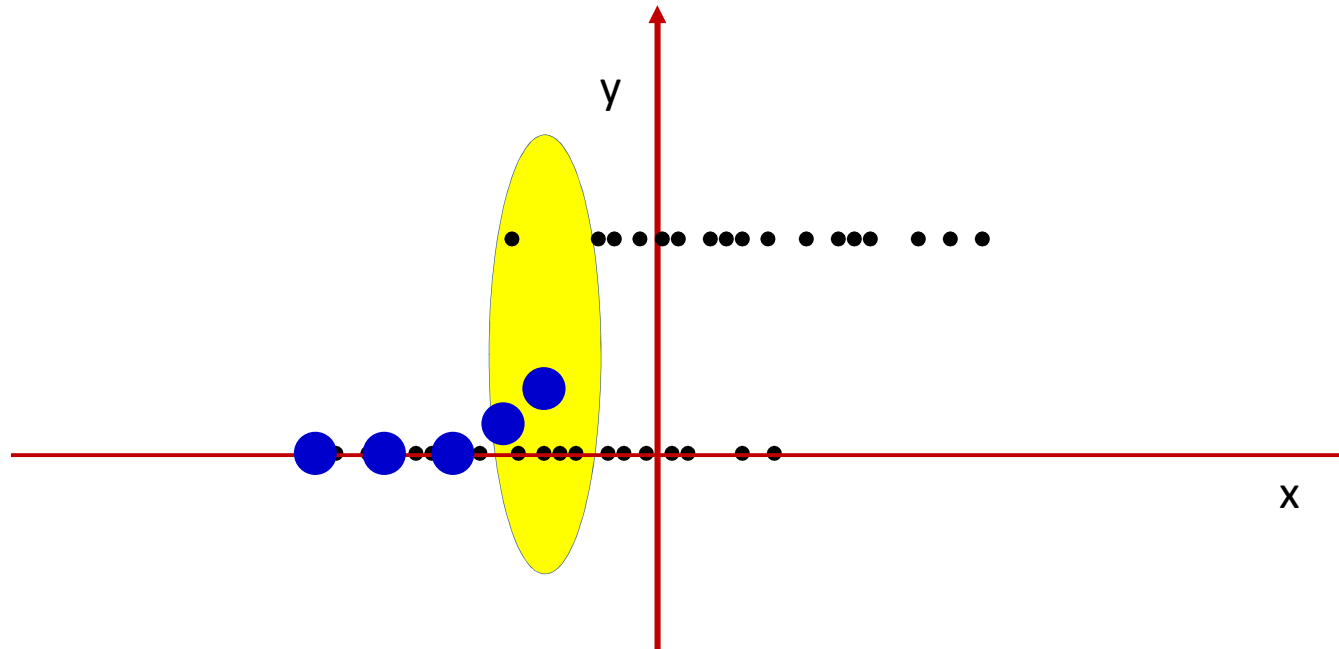

- Consider this differently: at each point look at a small window around that point
- Plot the average value within the window
 - This is an approximation of the *probability* of 1 at that point

The *probability* of $y=1$

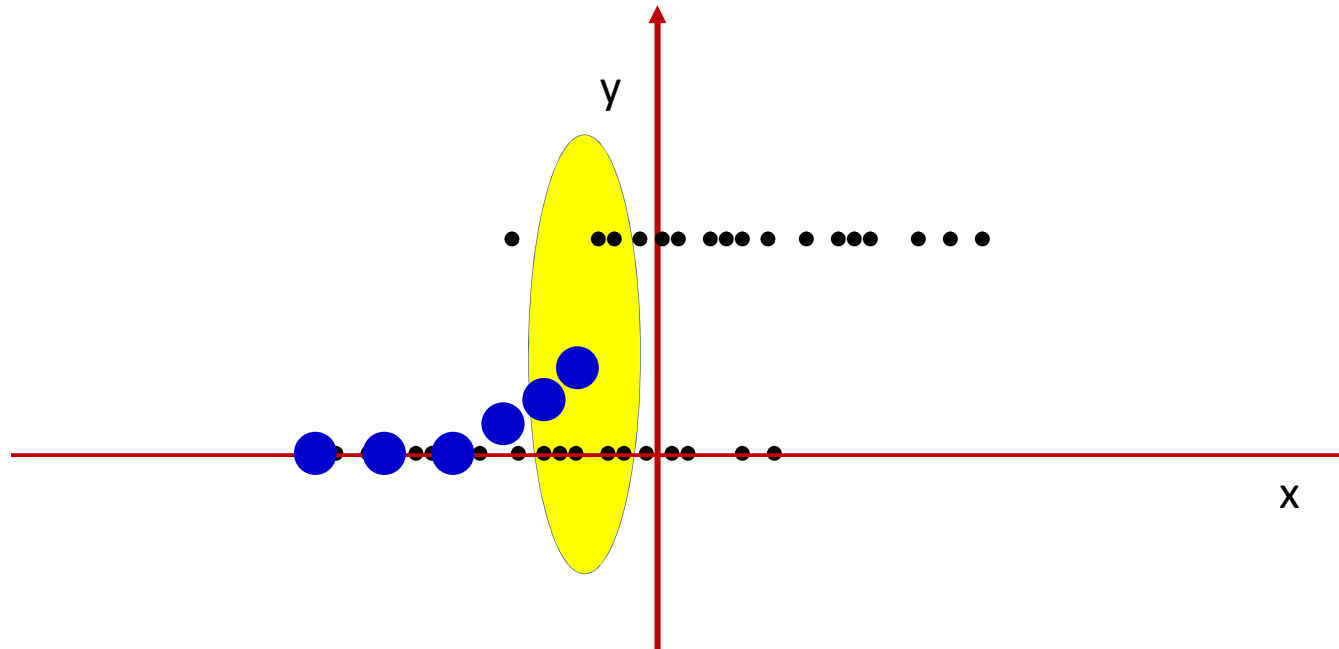

- Consider this differently: at each point look at a small window around that point
- Plot the average value within the window
 - This is an approximation of the *probability* of 1 at that point

The *probability* of $y=1$

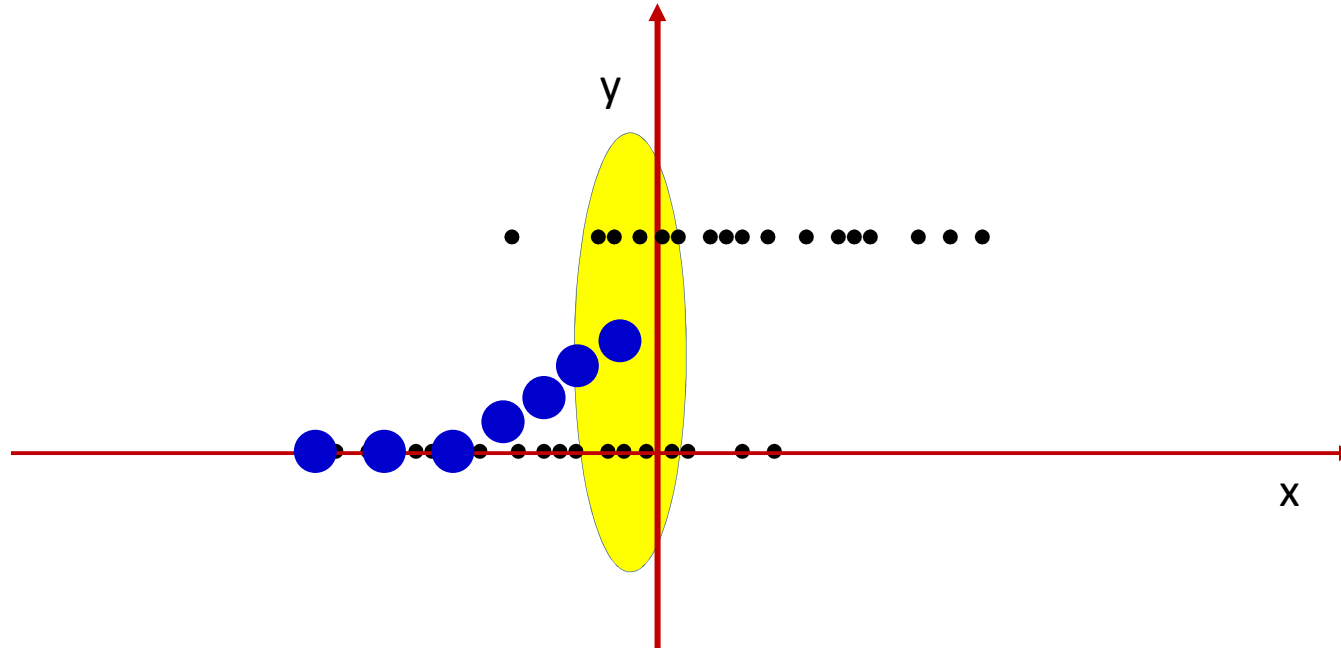

- Consider this differently: at each point look at a small window around that point
- Plot the average value within the window
 - This is an approximation of the *probability* of 1 at that point

The *probability* of $y=1$

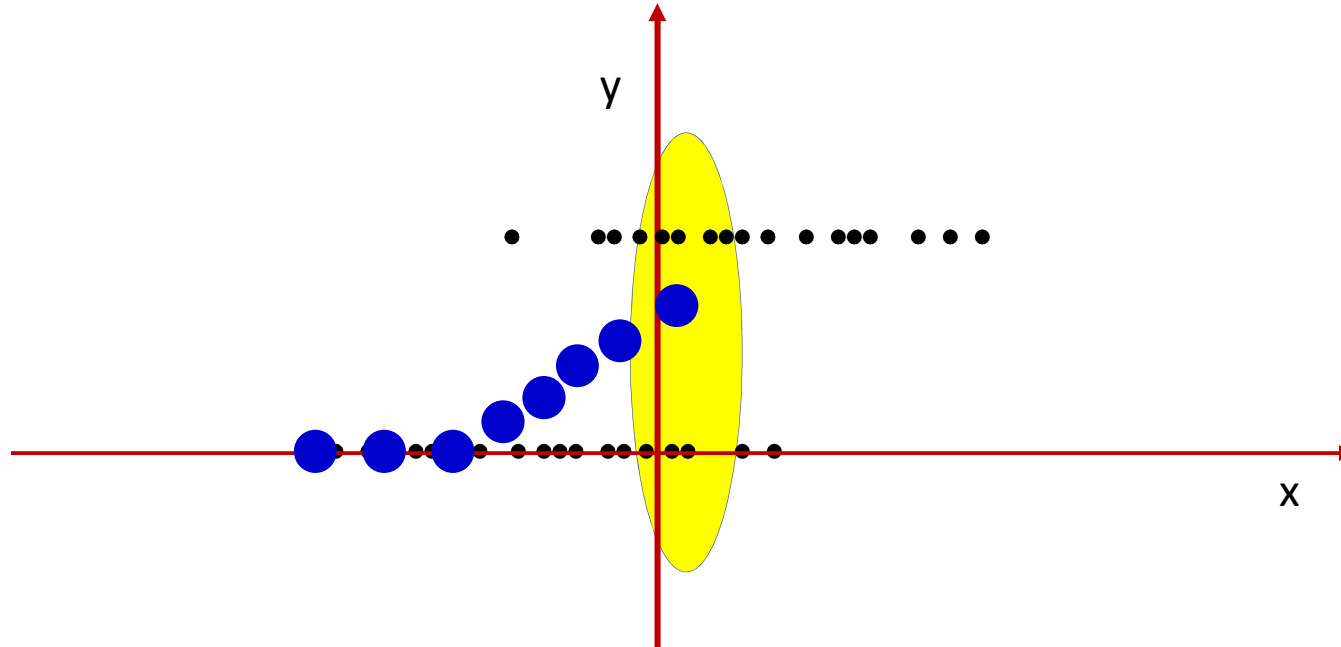

- Consider this differently: at each point look at a small window around that point
- Plot the average value within the window
 - This is an approximation of the *probability* of 1 at that point

The *probability* of $y=1$

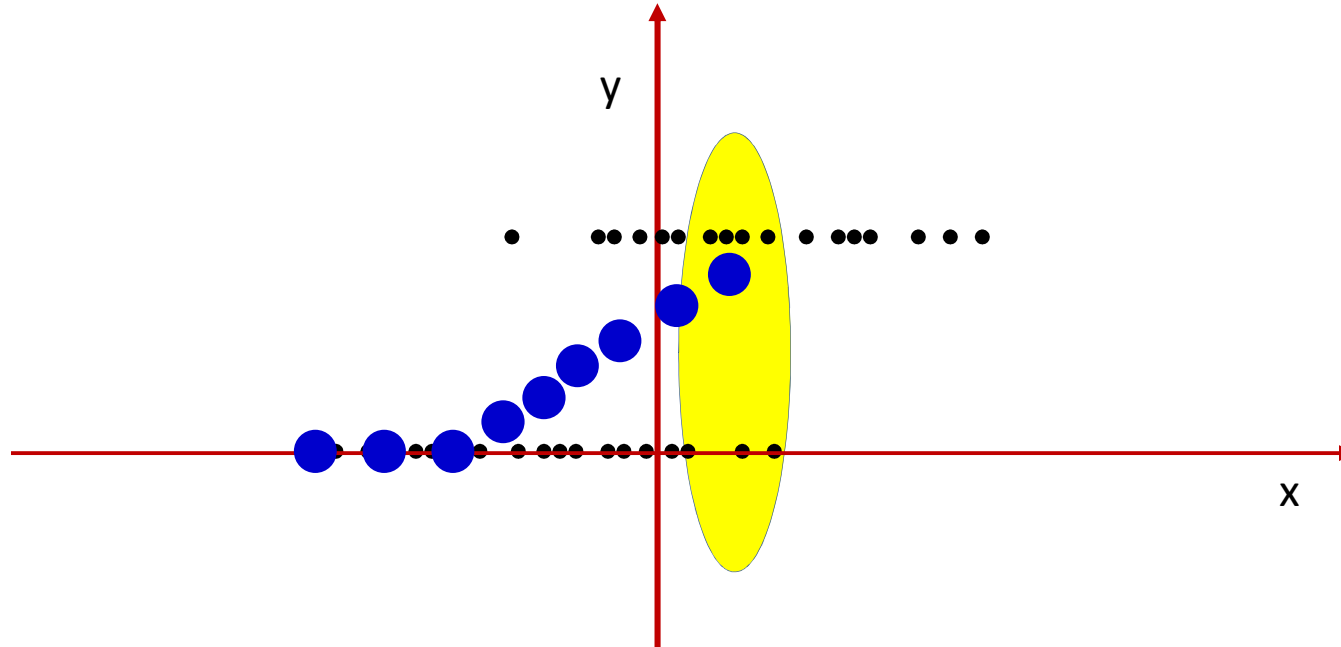

- Consider this differently: at each point look at a small window around that point
- Plot the average value within the window
 - This is an approximation of the *probability* of 1 at that point

The *probability* of $y=1$

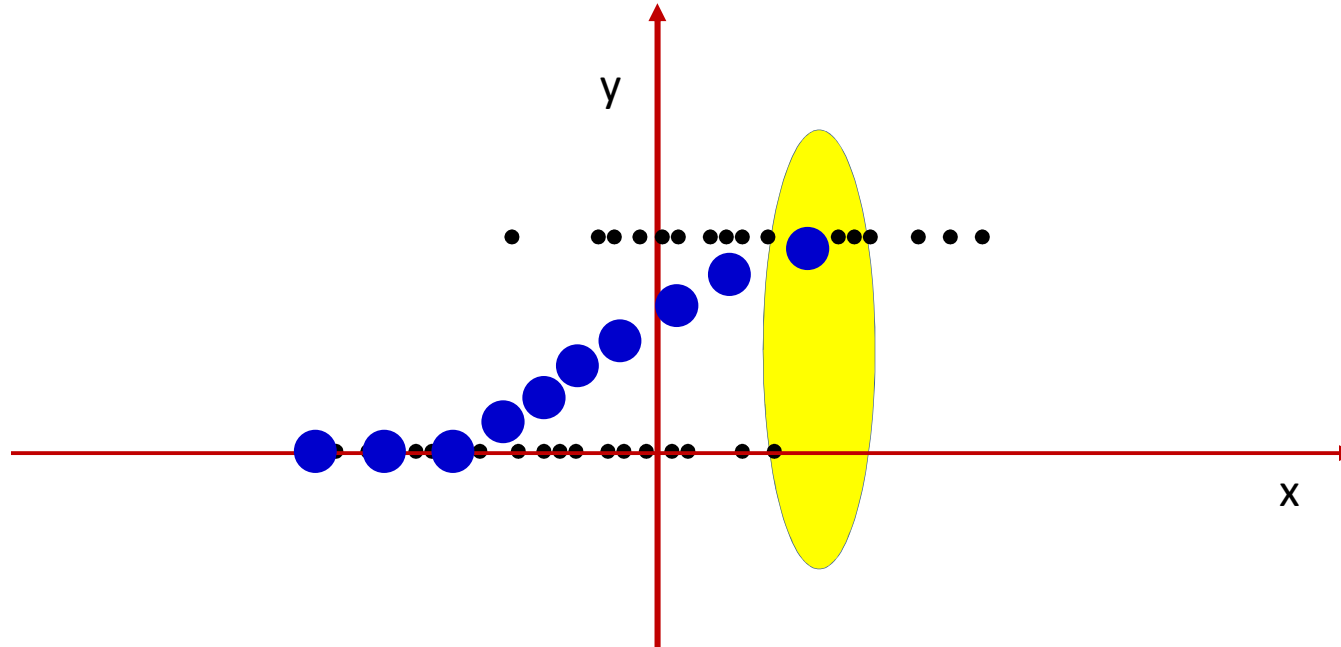

- Consider this differently: at each point look at a small window around that point
- Plot the average value within the window
 - This is an approximation of the *probability* of 1 at that point

The *probability* of $y=1$

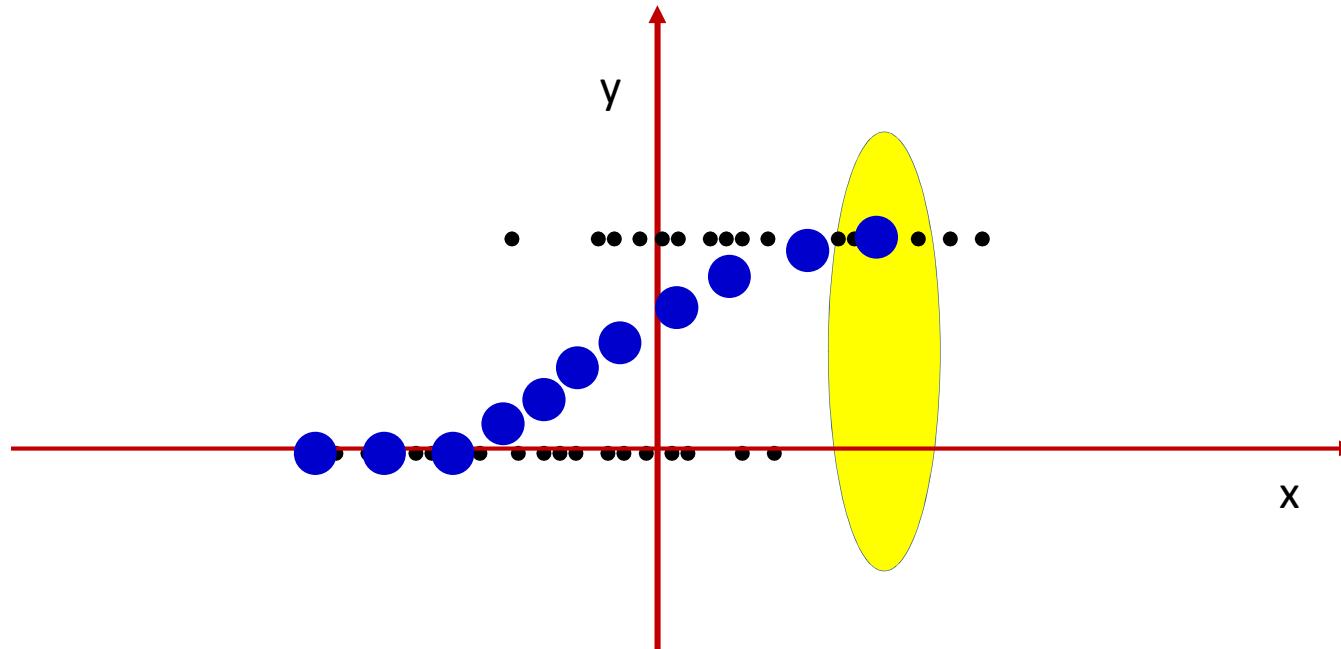

- Consider this differently: at each point look at a small window around that point
- Plot the average value within the window
 - This is an approximation of the *probability* of 1 at that point

The *probability* of $y=1$

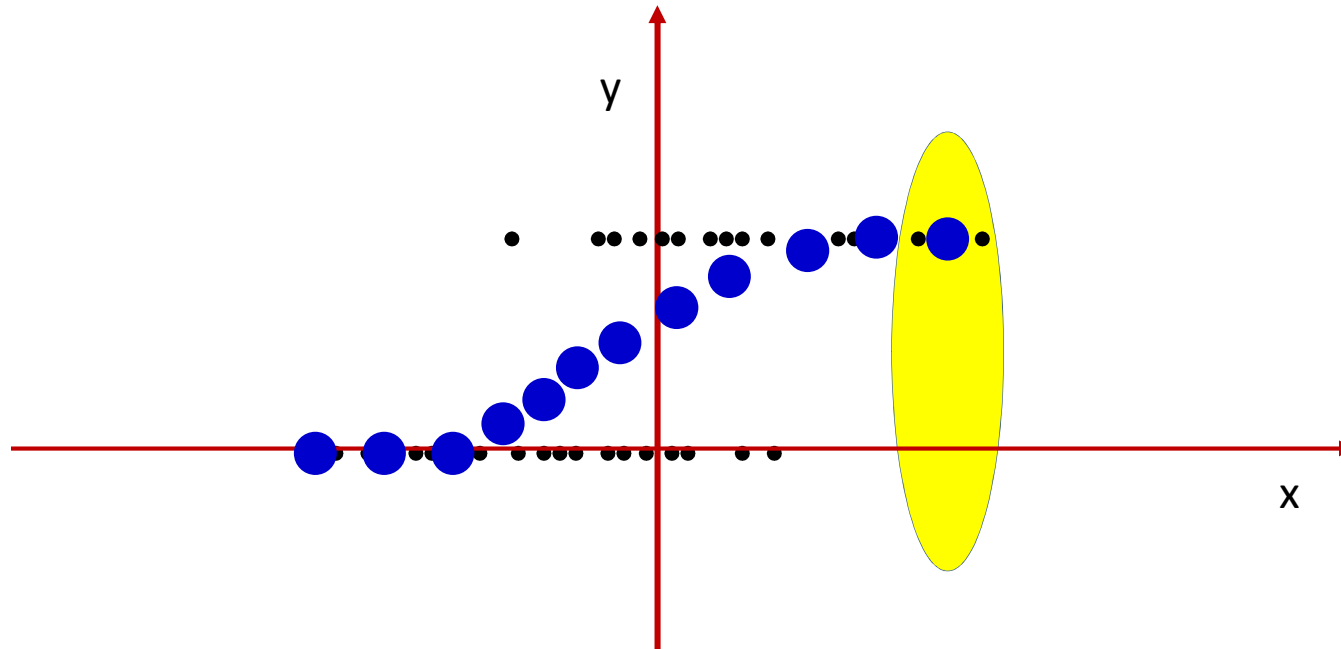

- Consider this differently: at each point look at a small window around that point
- Plot the average value within the window
 - This is an approximation of the *probability* of 1 at that point

The *probability* of $y=1$

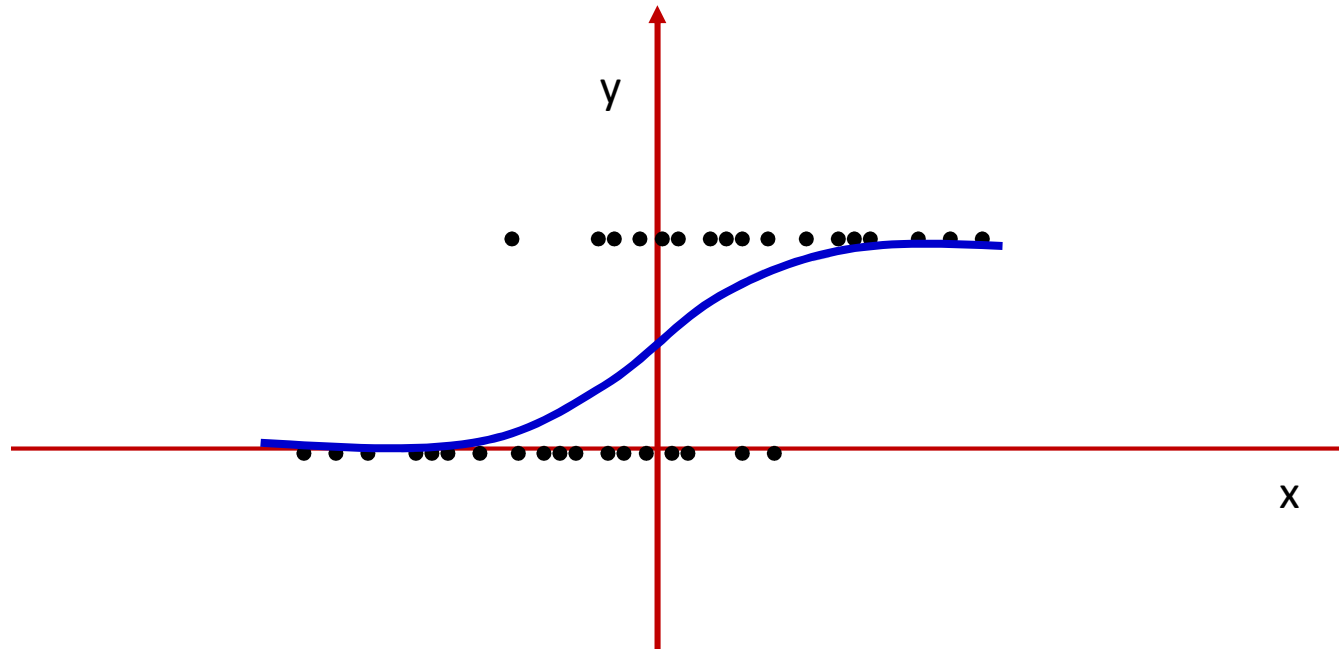

- Consider this differently: at each point look at a small window around that point
- Plot the average value within the window
 - This is an approximation of the *probability* of 1 at that point

The logistic regression model

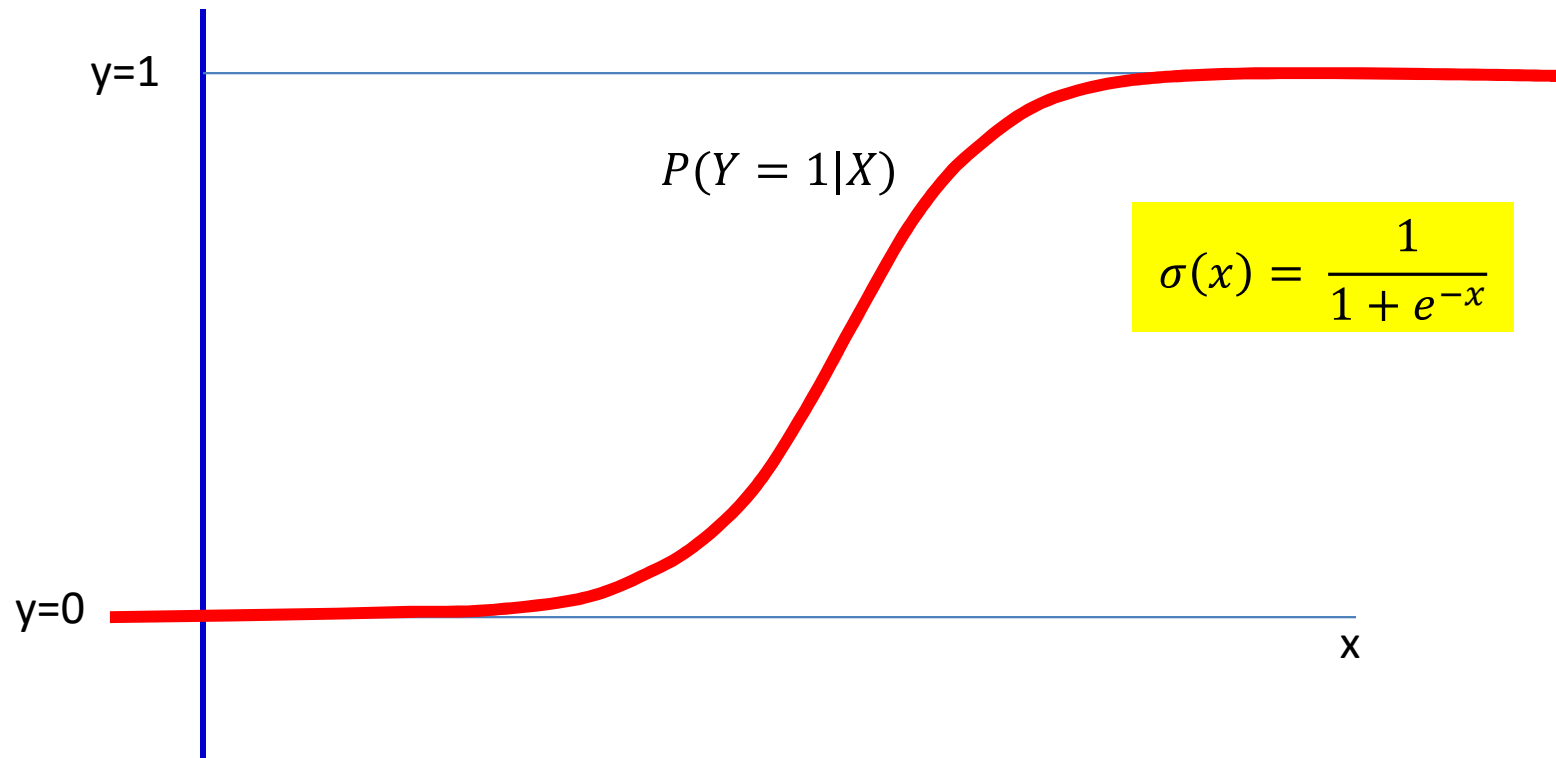

- Class 1 becomes increasingly probable going left to right
 - Very typical in many problems

Logistic regression

Decision: $y > 0.5$?

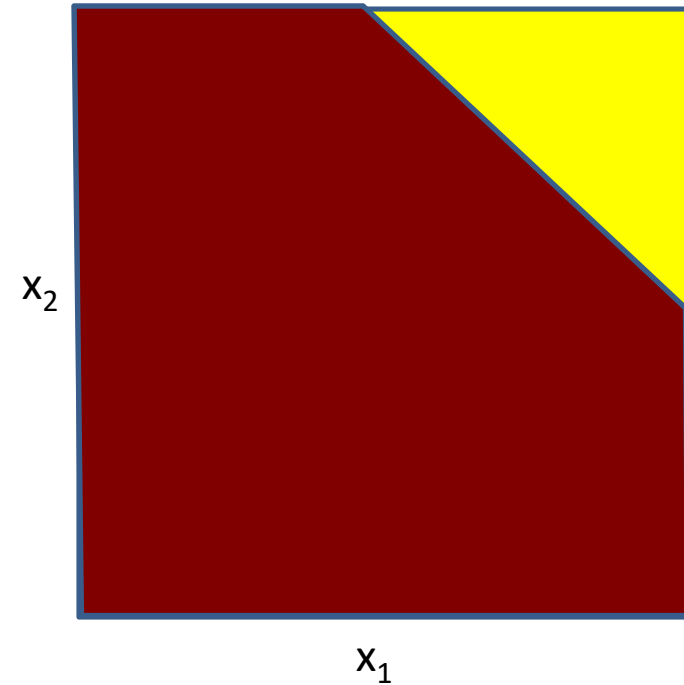
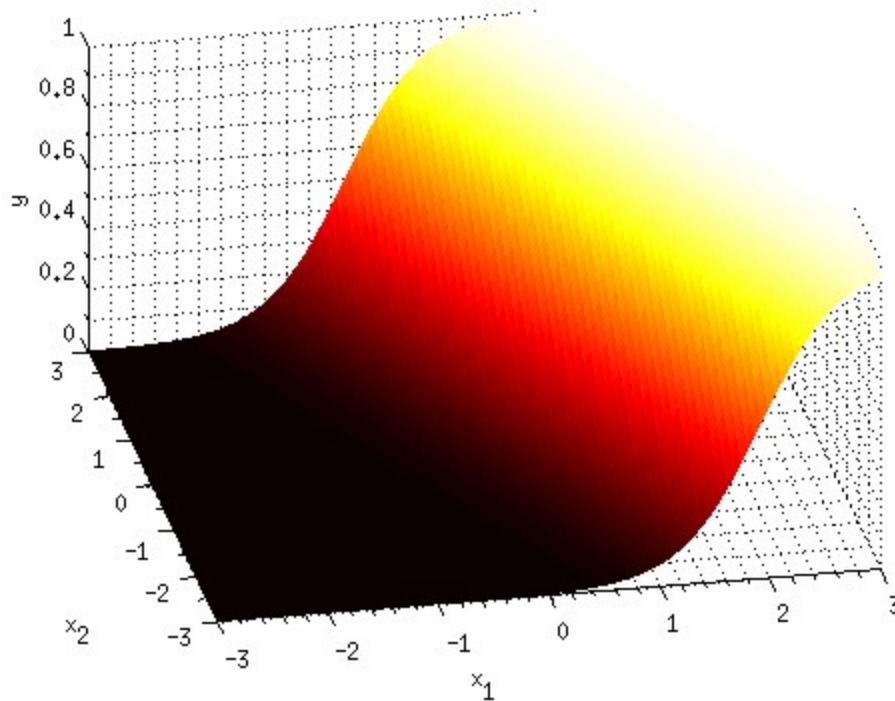

When X is a 2-D variable

$$P(Y = 1|X) = \frac{1}{1 + \exp(-\sum_i w_i x_i - b)}$$

- This is the perceptron with a sigmoid activation
 - It actually computes the *probability* that the input belongs to class 1

Perceptrons and probabilities

- We will return to the fact that perceptrons with sigmoidal activations actually model class probabilities in a later lecture
- But for now moving on..

Perceptrons with differentiable activation functions

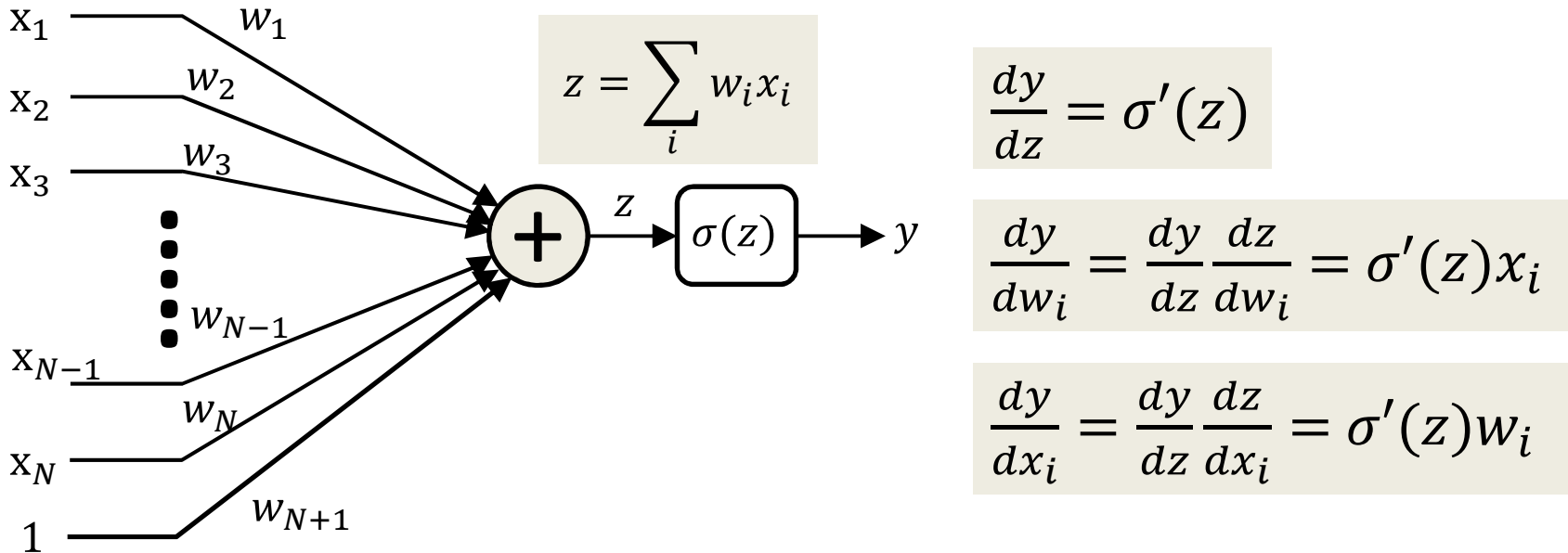

- $\sigma(z)$ is a differentiable function of z
 - $\frac{d\sigma(z)}{dz}$ is well-defined and finite for all z
- Using the chain rule, y is a differentiable function of both inputs x_i and weights w_i
- This means that we can compute the change in the output for *small* changes in either the input or the weights

Overall network is differentiable

Figure does not show bias connections

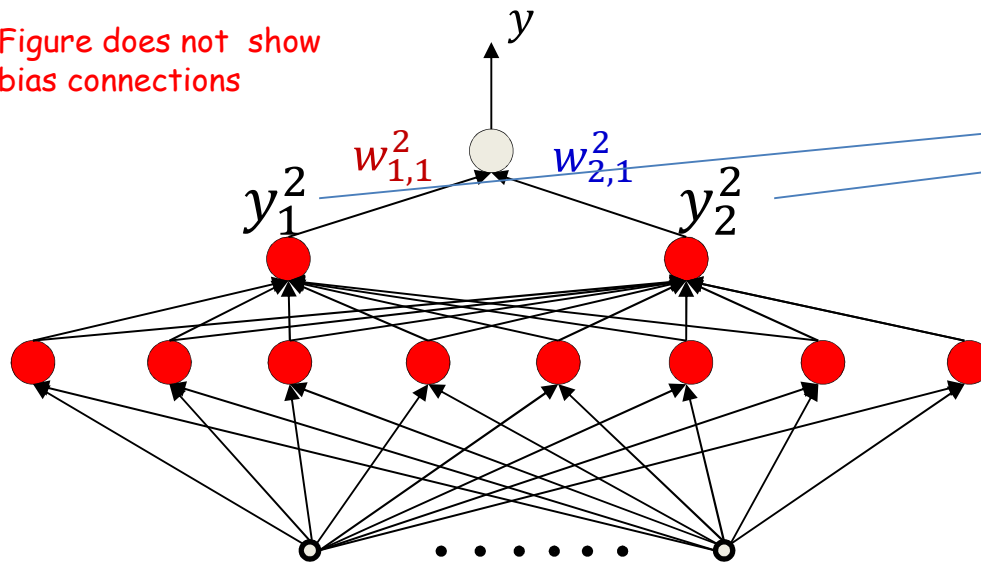

$$y = \sigma(w_{1,1}^2 y_1^2 + w_{2,1}^2 y_2^2 + w_{3,1}^2)$$

y = output of overall network

$w_{i,j}^k$ = weight connecting the i th unit of the k th layer to the j th unit of the $k+1$ -th layer

y_i^k = output of the i th unit of the k th layer

$\sigma()$ is differentiable w.r.t both w and y_i^k

- Every individual perceptron is differentiable w.r.t its inputs and its weights (including “bias” weight)
- By the chain rule, the overall function is differentiable w.r.t every parameter (weight or bias)
 - Small changes in the parameters result in measurable changes in output

Overall function is differentiable

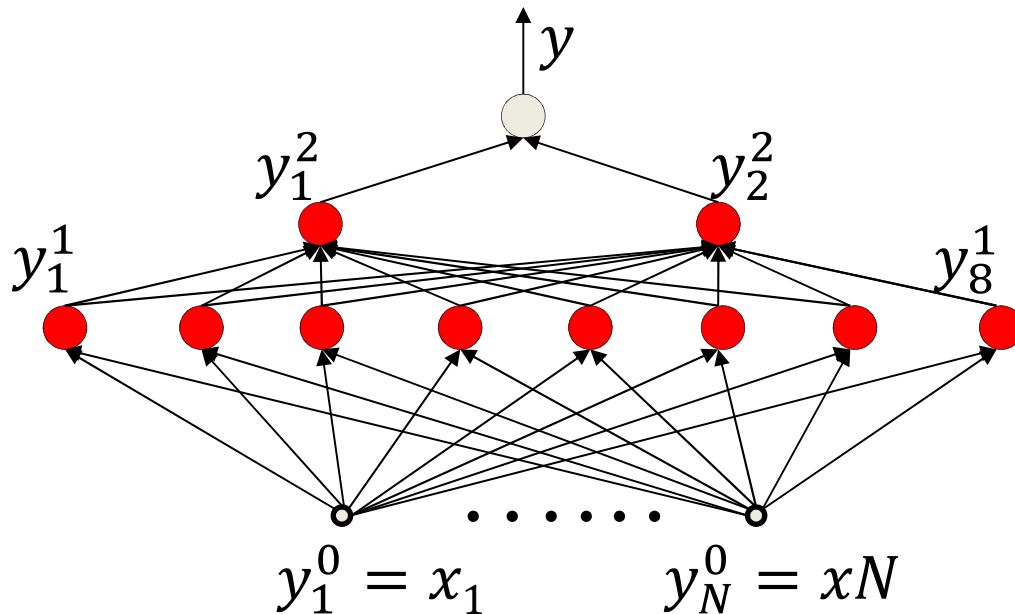

$$y_j^k = \sigma \left(\sum_i w_{i,j}^{k-1} y_i^{k-1} \right)$$

- The overall function is differentiable w.r.t every parameter
 - Small changes in the parameters result in measurable changes in the output
 - We will derive the actual derivatives using the chain rule later

Overall setting for “Learning” the MLP

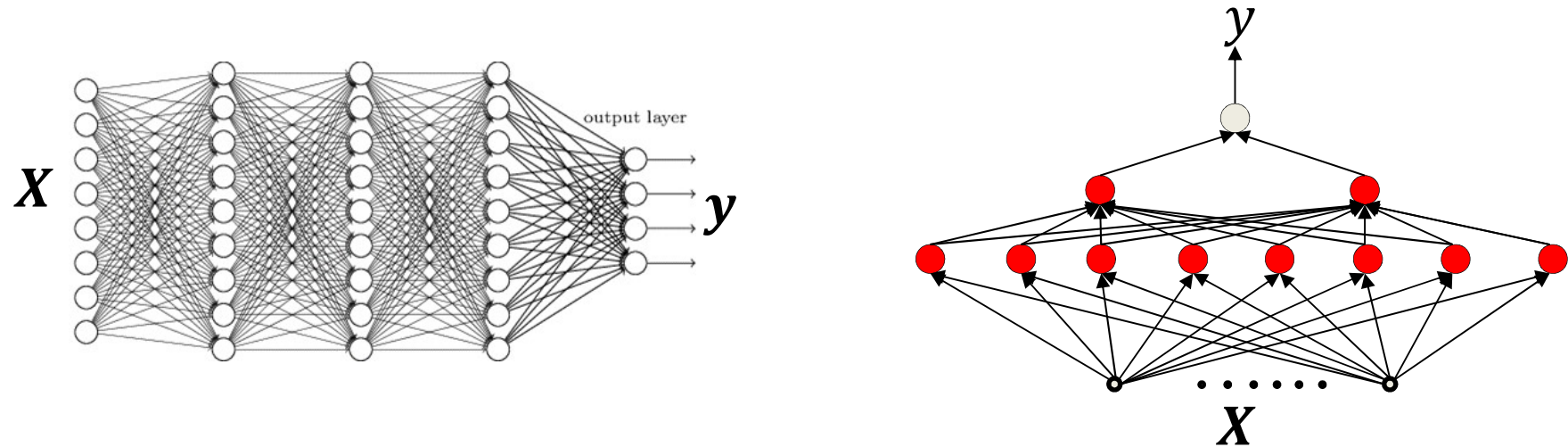

- Given a training set of input-output pairs $(X_1, d_1), (X_2, d_2), \dots, (X_N, d_N) \dots$
 - d is the *desired output* of the network in response to X
 - X and d may both be vectors
- ...we must find the network parameters such that the network produces the desired output for each training input
 - Or a close approximation of it
 - **The *architecture* of the network must be specified by us**

Recap: Learning the function

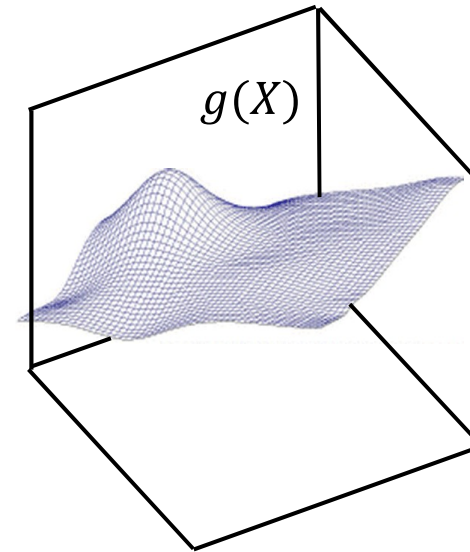
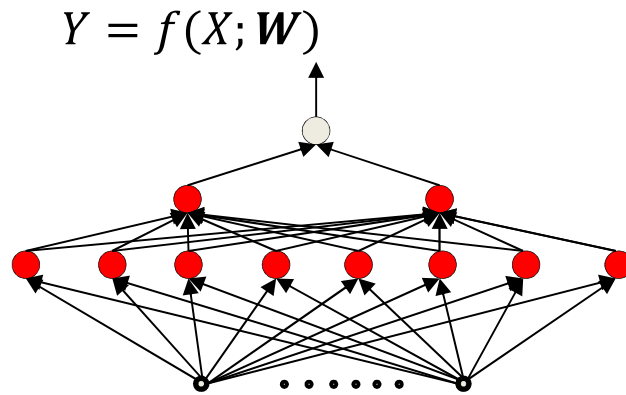

- When $f(X; \mathbf{W})$ has the capacity to exactly represent $g(X)$

$$\widehat{\mathbf{W}} = \operatorname{argmin}_{\mathbf{W}} \int_X \operatorname{div}(f(X; \mathbf{W}), g(X)) dX$$

- $\operatorname{div}()$ is a divergence function that goes to zero when $f(X; \mathbf{W}) = g(X)$

Minimizing *expected* error

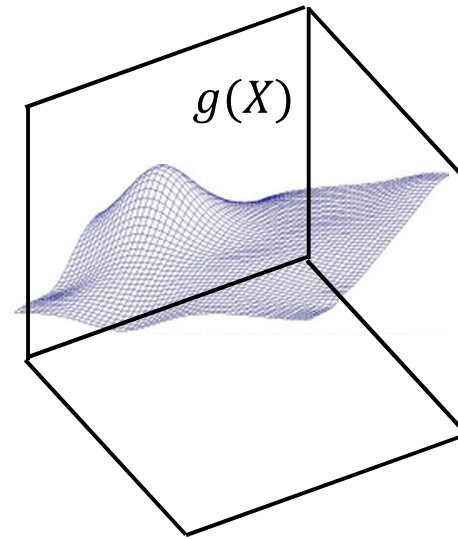
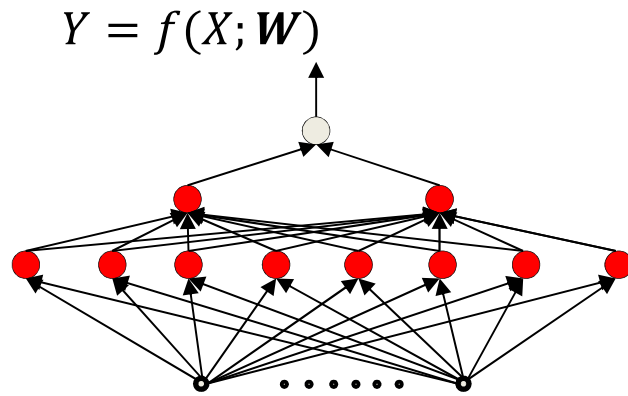

- More generally, assuming X is a random variable

$$\begin{aligned}\widehat{\mathbf{W}} &= \operatorname{argmin}_W \int_X \operatorname{div}(f(X; W), g(X)) P(X) dX \\ &= \operatorname{argmin}_W E[\operatorname{div}(f(X; W), g(X))]\end{aligned}$$

Recap: Sampling the function

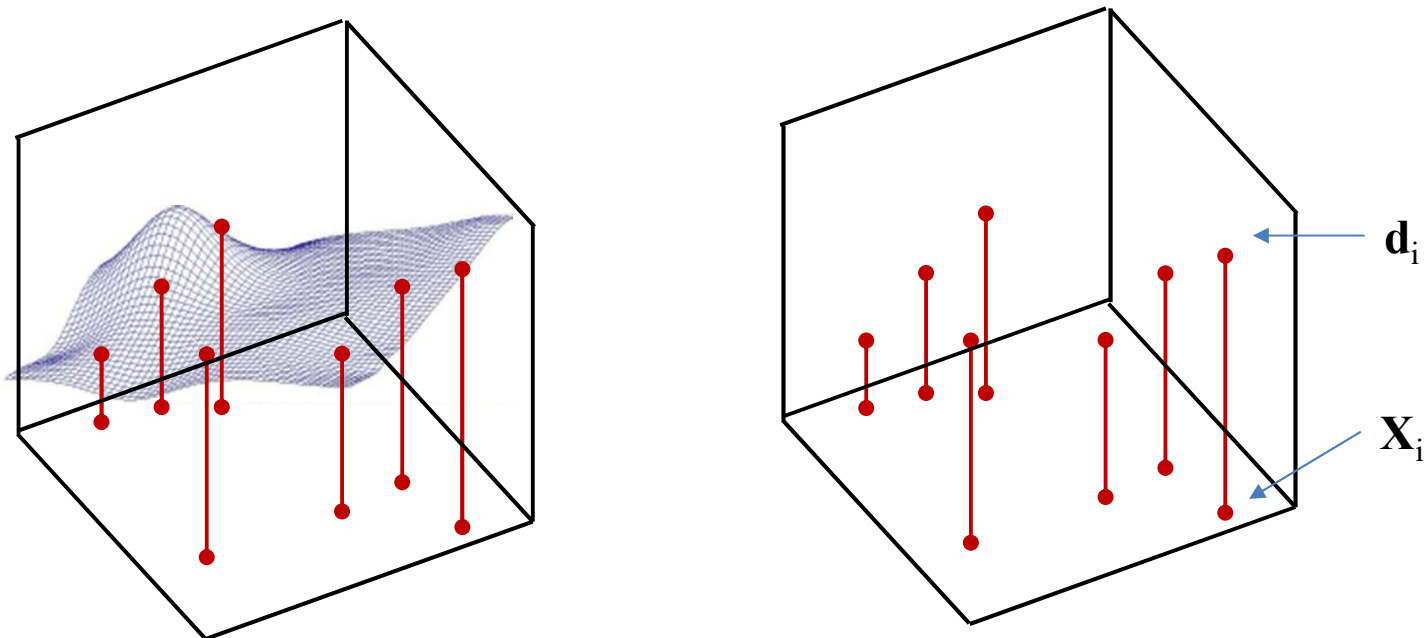

- *Sample $g(X)$*
 - Basically, get input-output pairs for a number of samples of input X_i
 - Many samples (X_i, d_i) , where $d_i = g(X_i) + \text{noise}$
 - Good sampling: the samples of X will be drawn from $P(X)$
- Estimate function from the samples

The *Empirical* risk

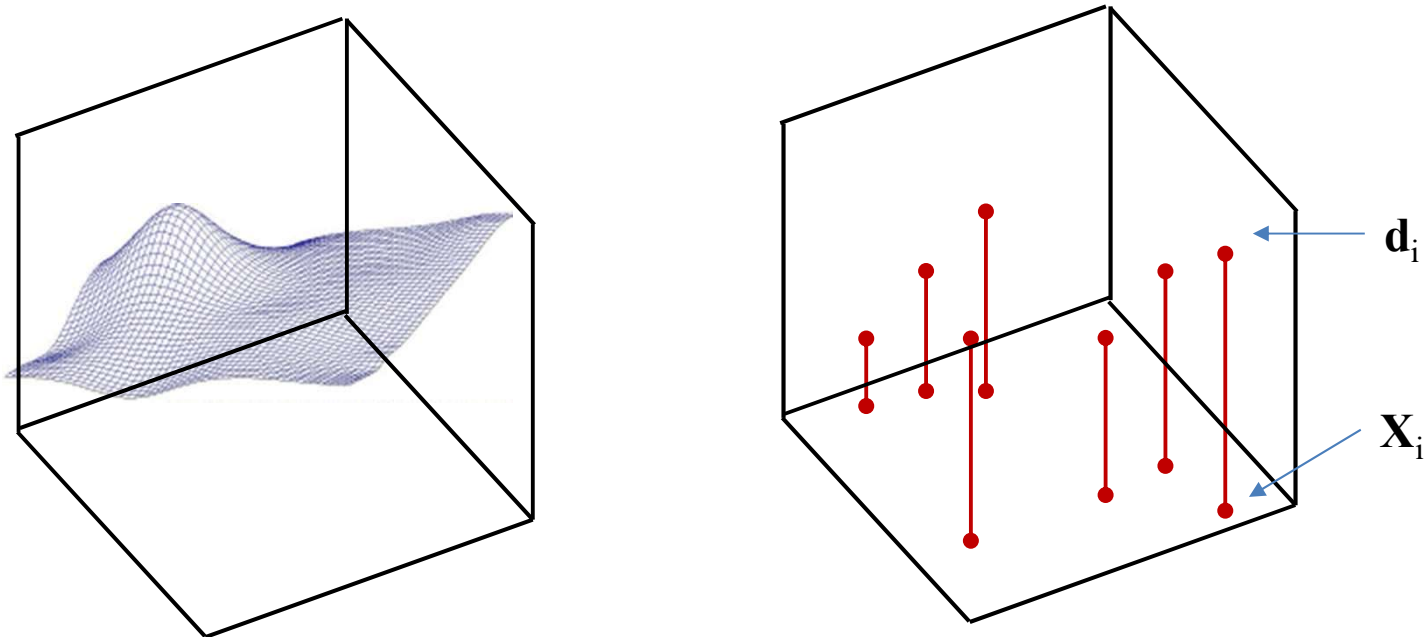

- The *expected* error (or risk) is the average error over the entire input space

$$E[\text{div}(f(X; W), g(X))] = \int_X \text{div}(f(X; W), g(X)) P(X) dX$$

- The *empirical estimate* of the expected error (or risk) is the *average* error over the samples

$$E[\text{div}(f(X; W), g(X))] \approx \frac{1}{N} \sum_{i=1}^N \text{div}(f(X_i; W), d_i)$$

Empirical Risk Minimization

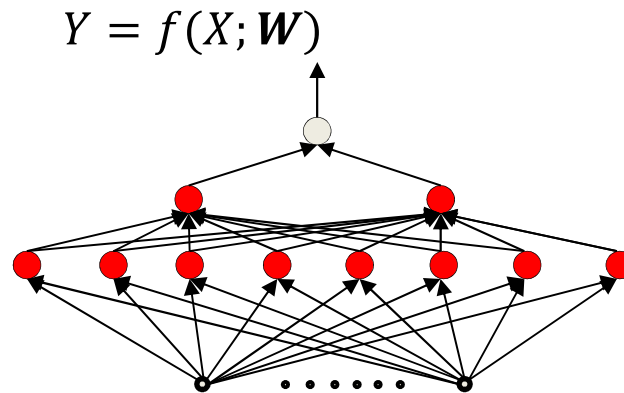

- Given a training set of input-output pairs $(X_1, d_1), (X_2, d_2), \dots, (X_N, d_N)$
 - Error on the i th instance: $div(f(X_i; W), d_i)$
 - Empirical average error (**Empirical Risk**) on all training data:

$$Loss(W) = \frac{1}{N} \sum_i div(f(X_i; W), d_i)$$

- Estimate the parameters to minimize the empirical estimate of expected error (**empirical risk**)

$$\widehat{W} = \underset{W}{\operatorname{argmin}} Loss(W)$$

- I.e. minimize the *empirical risk* over the drawn samples

Empirical Risk Minimization

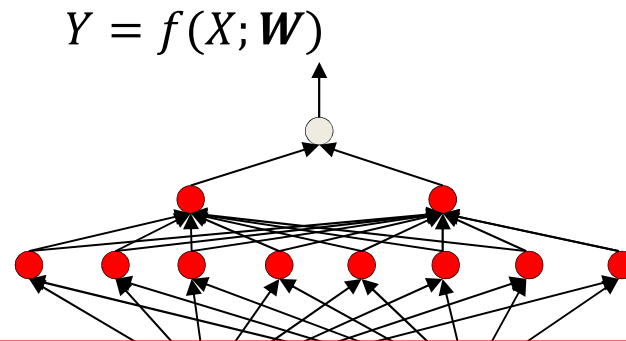

Note : Its really a measure of error, but using standard terminology, we will call it a "Loss"

- Note 2: The empirical risk $Loss(W)$ is only an empirical approximation to the true risk $E[div(f(X; W), g(X))]$ which is our *actual* minimization objective

$$Loss(W) = \frac{1}{N} \sum_i div(f(X_i; W), d_i)$$

- Estimate the parameters to minimize the empirical estimate of expected error

$$\widehat{W} = \underset{W}{\operatorname{argmin}} Loss(W)$$

- I.e. minimize the *empirical error* over the drawn samples

ERM for neural networks

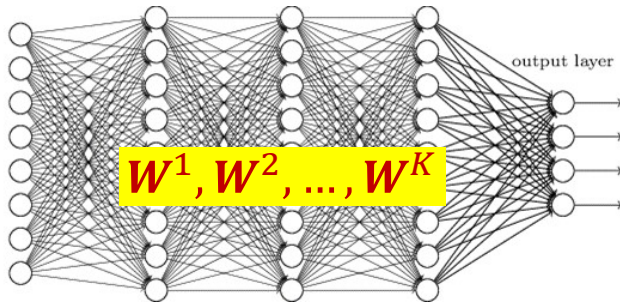

Actual output of network:

$$Y_i = \text{net}(X_i; \{w_{i,j}^k \forall i, j, k\}) \\ = \text{net}(X_i; W^1, W^2, \dots, W^K)$$

Desired output of network: d_i

Error on i-th training input: $\text{Div}(Y_i, d_i; W^1, W^2, \dots, W^K)$

Average training error(loss):

$$\text{Loss}(W^1, W^2, \dots, W^K) = \frac{1}{N} \sum_{i=1}^N \text{Div}(Y_i, d_i; W^1, W^2, \dots, W^K)$$

- What is the exact form of $\text{Div}()$? More on this later
- Optimize network parameters to minimize the total error over all training inputs

Problem Statement

- Given a training set of input-output pairs $(X_1, d_1), (X_2, d_2), \dots, (X_N, d_N)$

- Minimize the following function

$$Loss(W) = \frac{1}{N} \sum_i div(f(X_i; W), d_i)$$

w.r.t W

- This is problem of function minimization
 - An instance of optimization

Story so far

- We learn networks by “fitting” them to training instances drawn from a target function
- Learning networks of threshold-activation perceptrons requires solving a hard combinatorial-optimization problem
 - Because we cannot compute the influence of small changes to the parameters on the overall error
- Instead we use continuous activation functions with non-zero derivatives to enables us to estimate network parameters
 - This makes the output of the network differentiable w.r.t every parameter in the network
 - The *logistic* activation perceptron actually computes the *a posteriori* probability of the output given the input
- We define differentiable *divergence* between the output of the network and the desired output for the training instances
 - And a total error, which is the average divergence over all training instances
- We optimize network parameters to minimize this error
 - Empirical risk minimization
- This is an instance of function minimization

- **A CRASH COURSE ON FUNCTION OPTIMIZATION**

A brief note on derivatives..

derivative

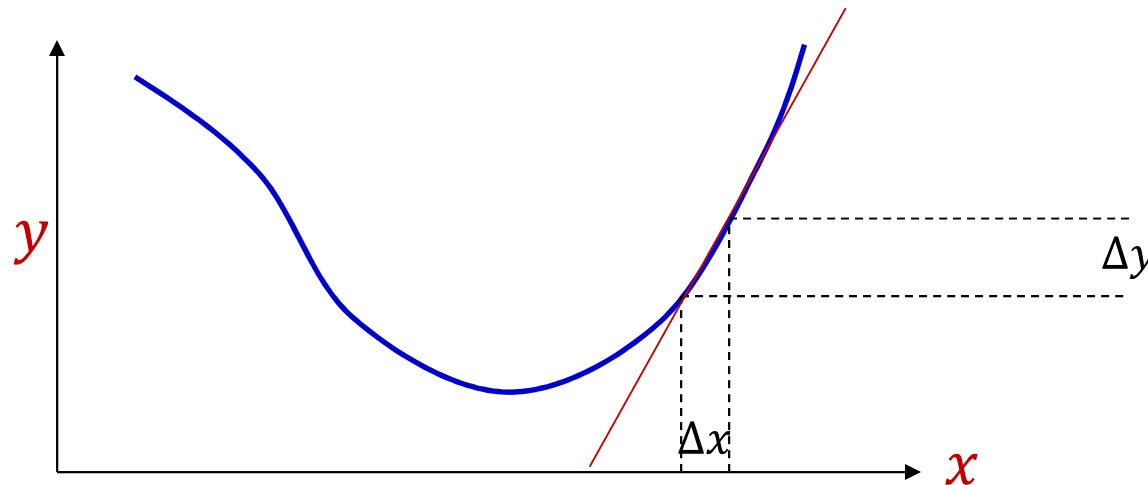

- A derivative of a function at any point tells us how much a minute increment to the *argument* of the function will increment the *value* of the function
 - For any $y = f(x)$, expressed as a multiplier α to a tiny increment Δx to obtain the increments Δy to the output

$$\Delta y = \alpha \Delta x$$

- Based on the fact that at a fine enough resolution, any smooth, continuous function is locally linear at any point

Scalar function of scalar argument

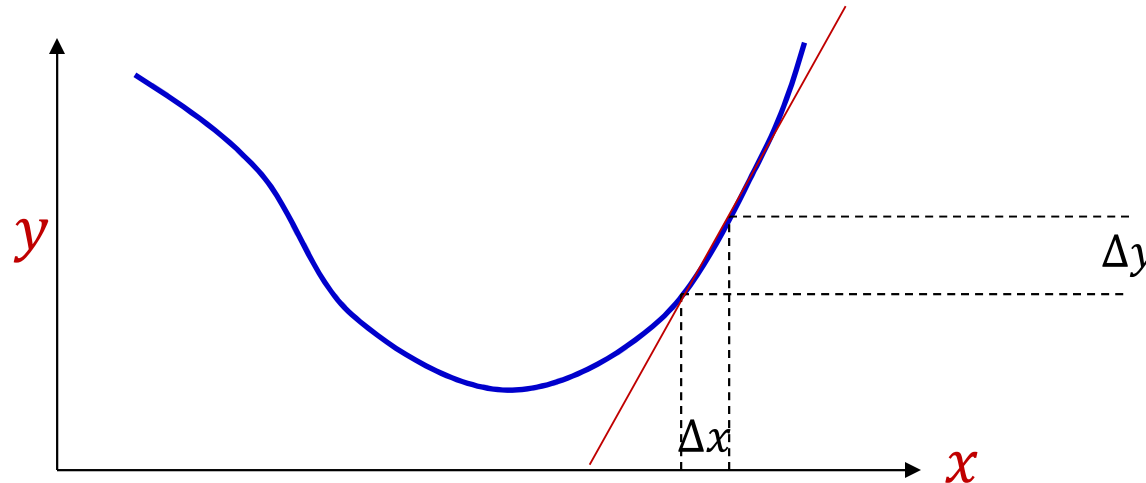

- When x and y are scalar

$$y = f(x)$$

- Derivative:

$$\Delta y = \alpha \Delta x$$

- Often represented (using somewhat inaccurate notation) as $\frac{dy}{dx}$
- Or alternately (and more reasonably) as $f'(x)$

Multivariate scalar function: Scalar function of *vector* argument

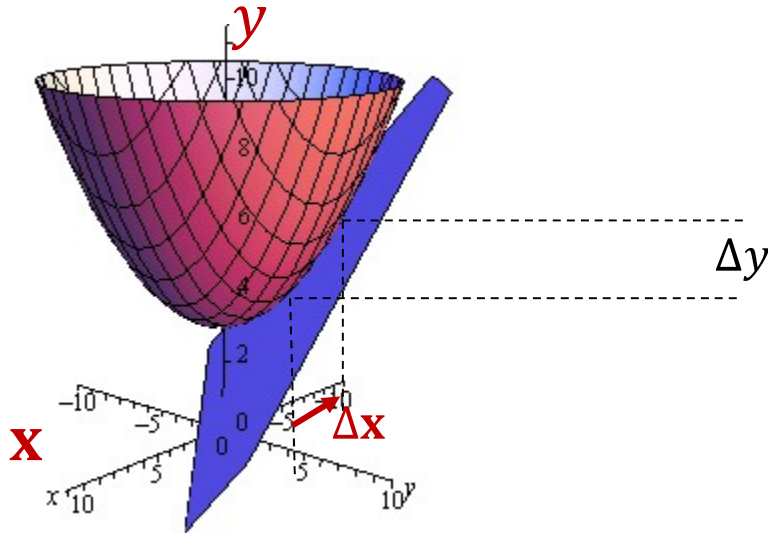

Note: $\Delta \mathbf{x}$ is now a vector

$$\Delta \mathbf{x} = \begin{bmatrix} \Delta x_1 \\ \vdots \\ \Delta x_D \end{bmatrix}$$

$$\Delta y = \alpha \Delta \mathbf{x}$$

- Giving us that α is a row vector: $\alpha = [\alpha_1 \quad \cdots \quad \alpha_D]$
$$\Delta y = \alpha_1 \Delta x_1 + \alpha_2 \Delta x_2 + \cdots + \alpha_D \Delta x_D$$
- The *partial* derivative α_i gives us how y increments when *only* x_i is incremented
- Often represented as $\frac{\partial y}{\partial x_i}$

$$\Delta y = \frac{\partial y}{\partial x_1} \Delta x_1 + \frac{\partial y}{\partial x_2} \Delta x_2 + \cdots + \frac{\partial y}{\partial x_D} \Delta x_D$$

Multivariate scalar function: Scalar function of *vector* argument

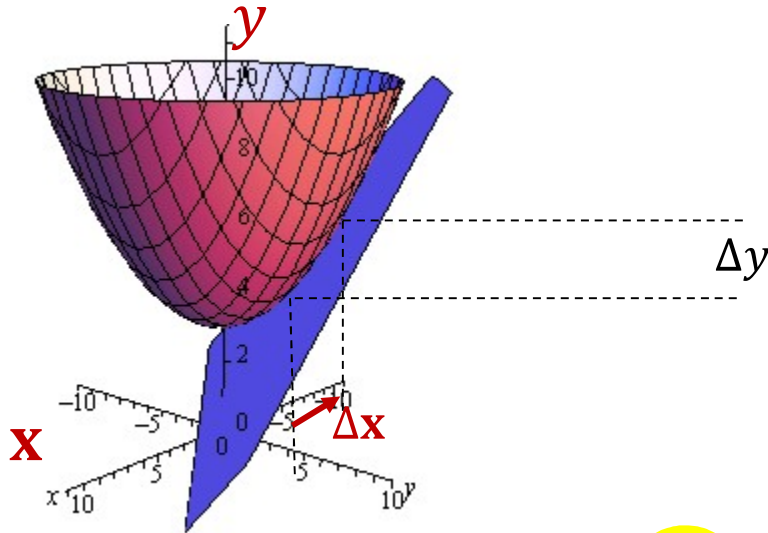

Note: $\Delta \mathbf{x}$ is now a vector

$$\Delta \mathbf{x} = \begin{bmatrix} \Delta x_1 \\ \vdots \\ \Delta x_D \end{bmatrix}$$

$$\Delta y = \nabla_{\mathbf{x}} y \Delta \mathbf{x}$$

- Where

$$\nabla_{\mathbf{x}} y = \begin{bmatrix} \frac{\partial y}{\partial x_1} & \dots & \frac{\partial y}{\partial x_D} \end{bmatrix}$$

We will be using this symbol for vector and matrix derivatives

- You may be more familiar with the term “gradient” which is actually defined as the transpose of the derivative

Caveat about following slides

- The following slides speak of optimizing a function w.r.t a variable “ x ”
- This is only mathematical notation. In our actual network optimization problem we would be optimizing w.r.t. network weights “ w ”
- To reiterate – “ x ” in the slides represents the variable that we’re optimizing a function over and not the input to a neural network
- **Do not get confused!**



The problem of optimization

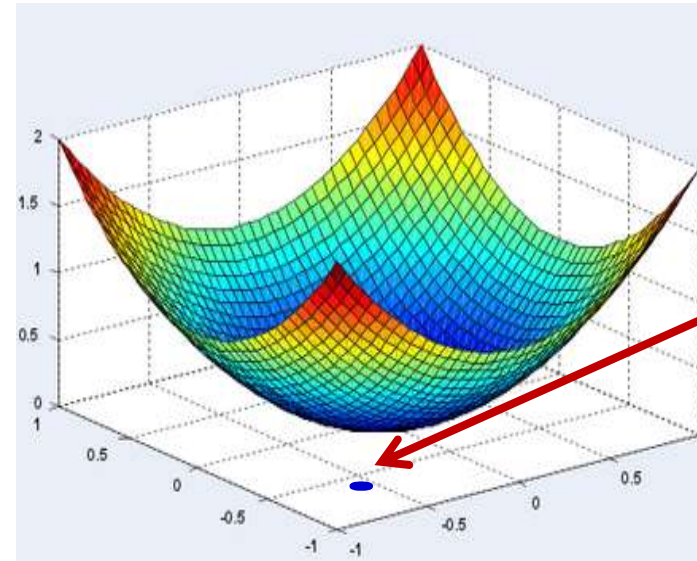
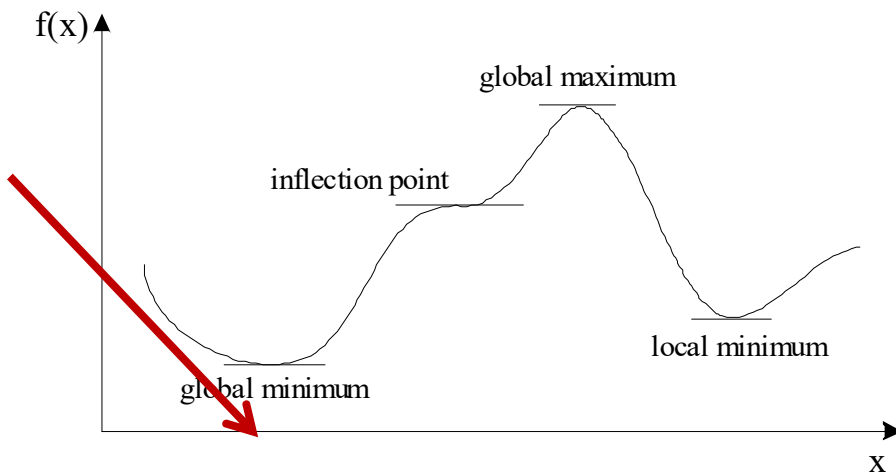

- General problem of optimization: find the value of x where $f(x)$ is minimum

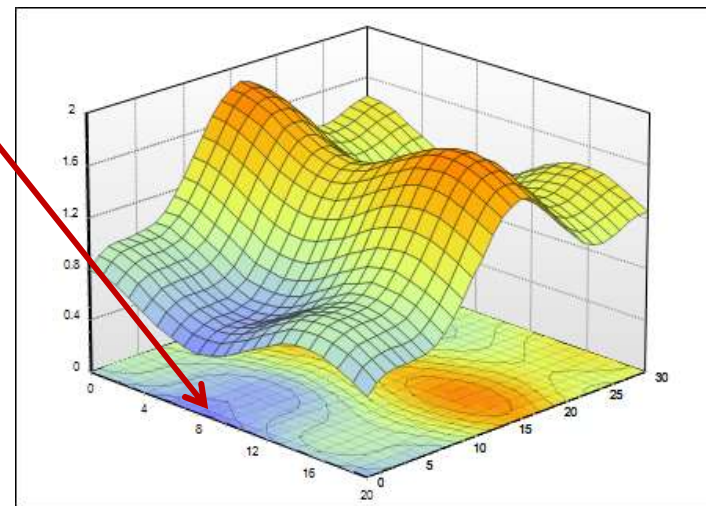

Finding the minimum of a function

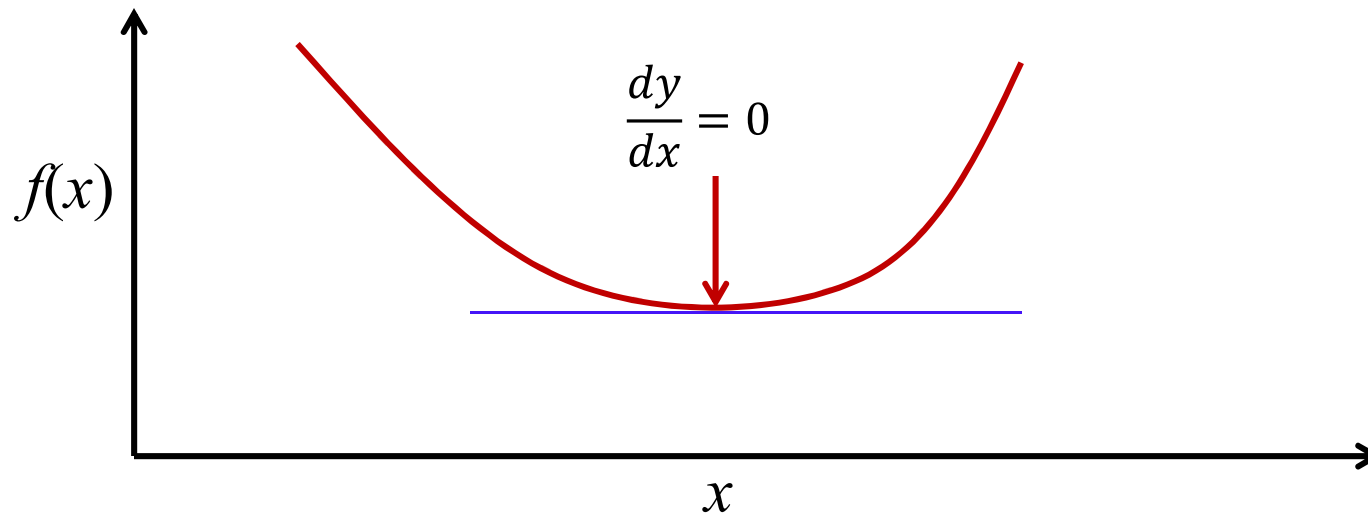

- Find the value x at which $f'(x) = 0$
 - Solve

$$\frac{df(x)}{dx} = 0$$

- The solution is a “turning point”
 - Derivatives go from positive to negative or vice versa at this point
- But is it a minimum?

Turning Points

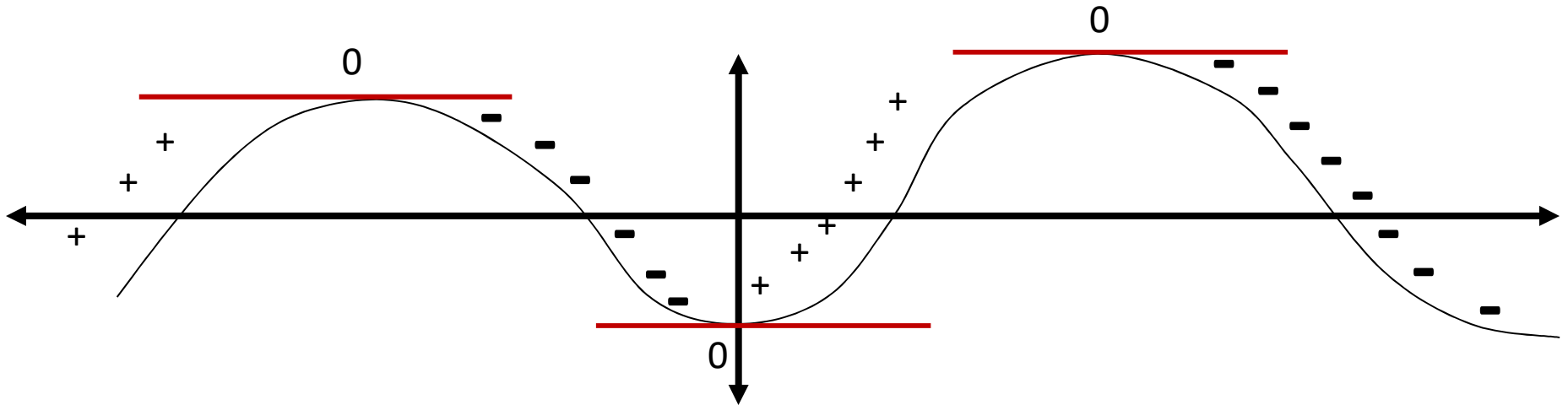

- Both *maxima* and *minima* have zero derivative
- Both are turning points

Derivatives of a curve

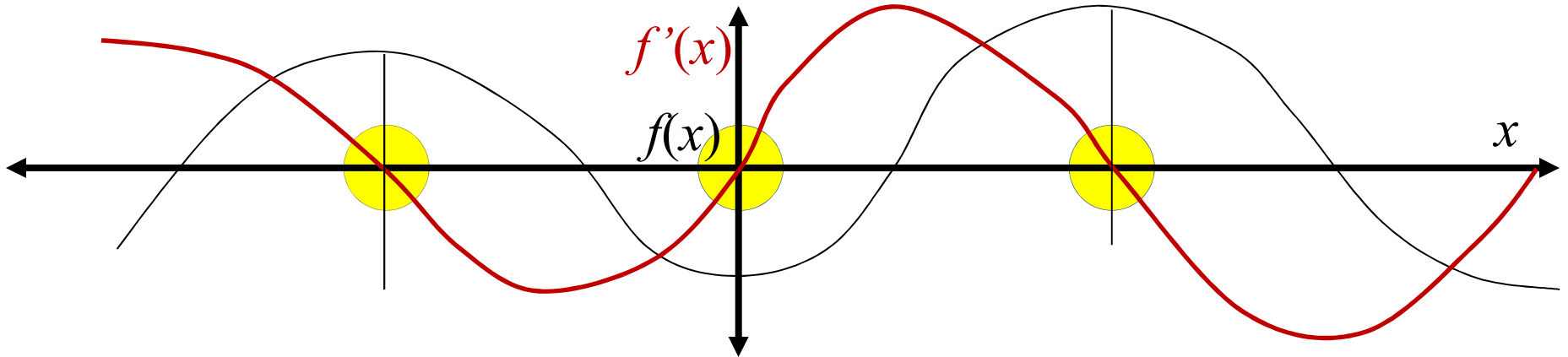

- Both *maxima* and *minima* are turning points
- Both *maxima* and *minima* have **zero derivative**

Derivative of the derivative of the curve

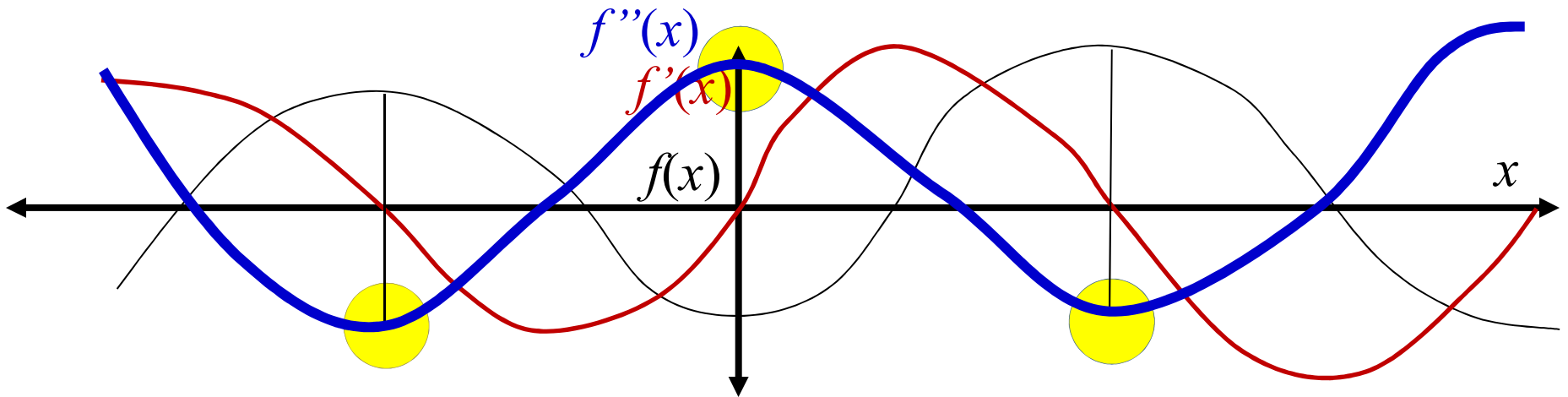

- Both *maxima* and *minima* are turning points
- Both *maxima* and *minima* have zero derivative
- The *second derivative* $f''(x)$ is $-ve$ at maxima and $+ve$ at minima!

Soln: Finding the minimum or maximum of a function

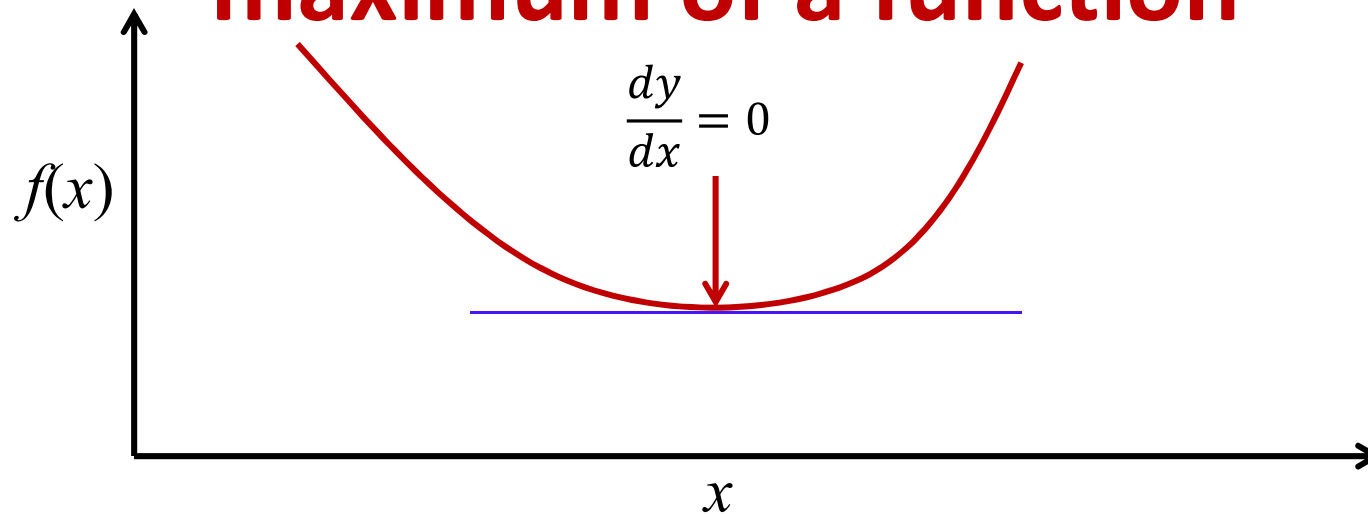

- Find the value x at which $f'(x) = 0$: Solve

$$\frac{df(x)}{dx} = 0$$

- The solution x_{soln} is a turning point
- Check the double derivative at x_{soln} : compute

$$f''(x_{soln}) = \frac{df'(x_{soln})}{dx}$$

- If $f''(x_{soln})$ is positive x_{soln} is a minimum, otherwise it is a maximum

A note on derivatives of functions of single variable

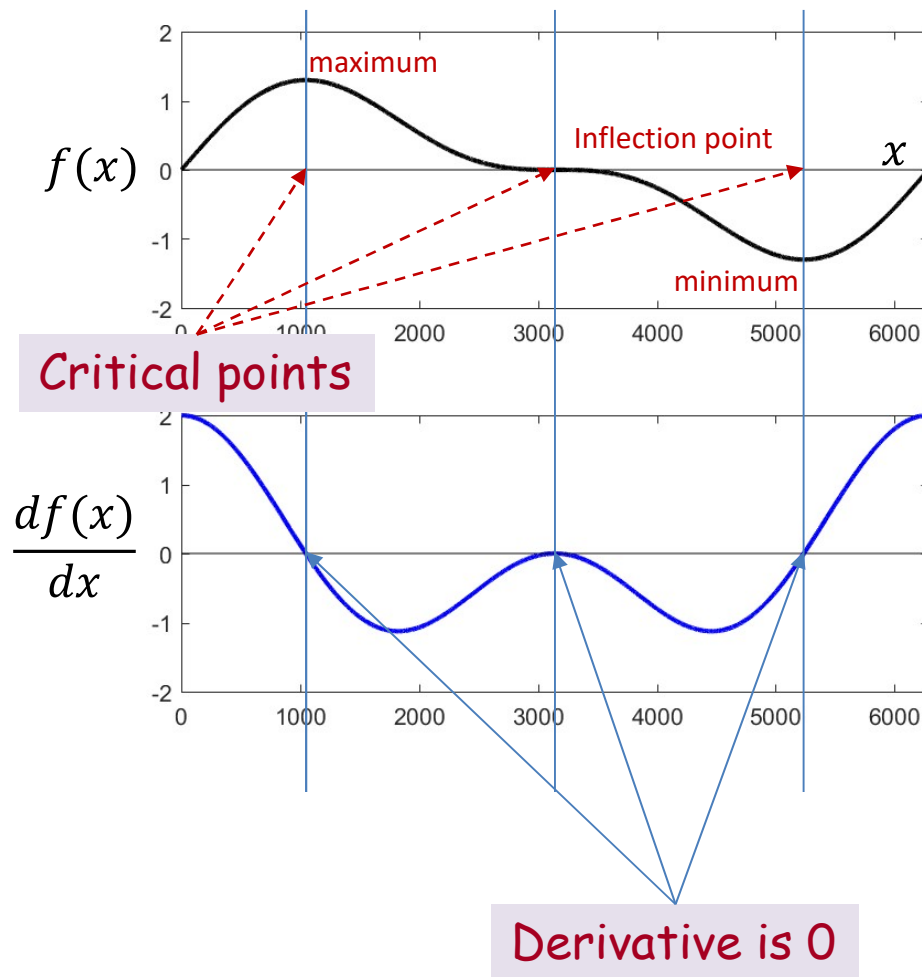

- All locations with zero derivative are *critical* points
 - These can be local maxima, local minima, or inflection points

A note on derivatives of functions of single variable

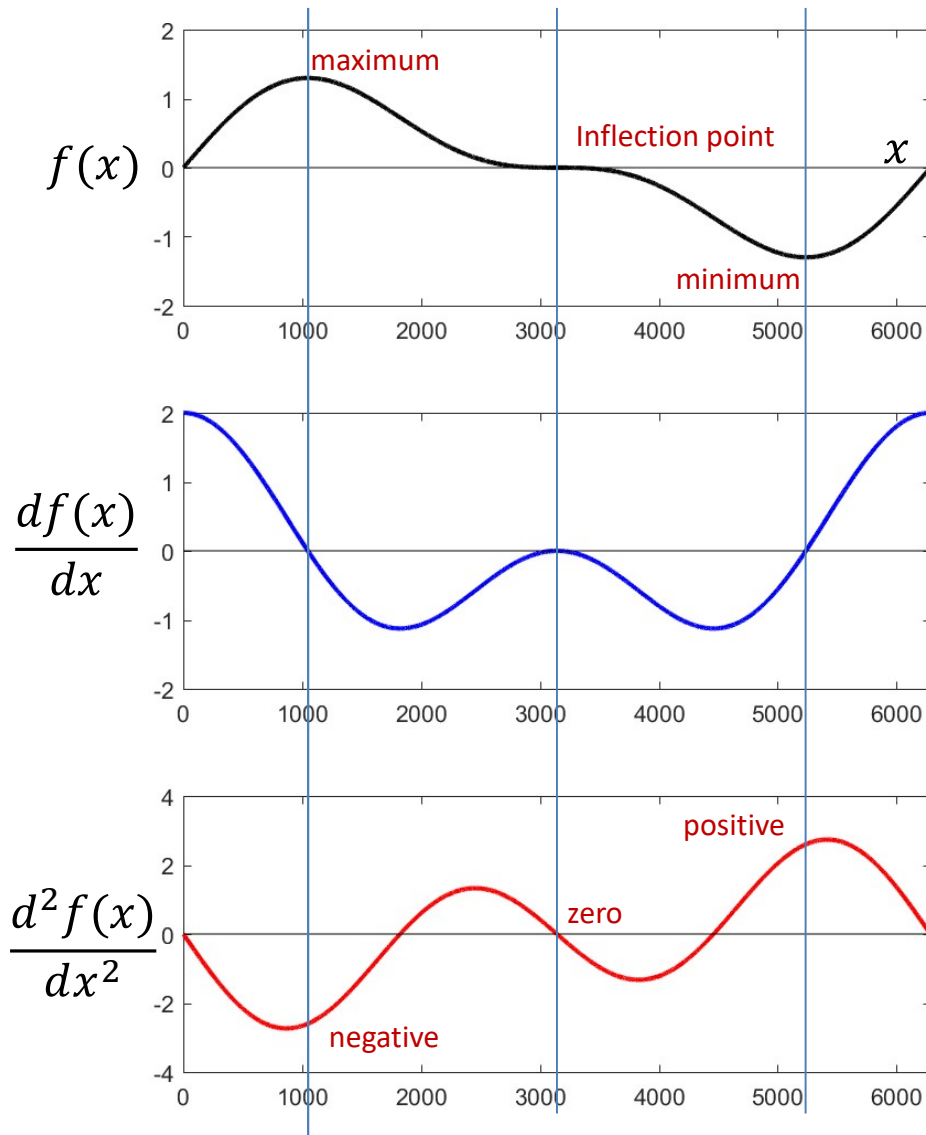

- All locations with zero derivative are *critical* points
 - These can be local maxima, local minima, or inflection points
- The *second* derivative is
 - ≥ 0 at minima
 - ≤ 0 at maxima
 - Zero at inflection points
- It's a little more complicated for functions of multiple variables..

What about functions of multiple variables?

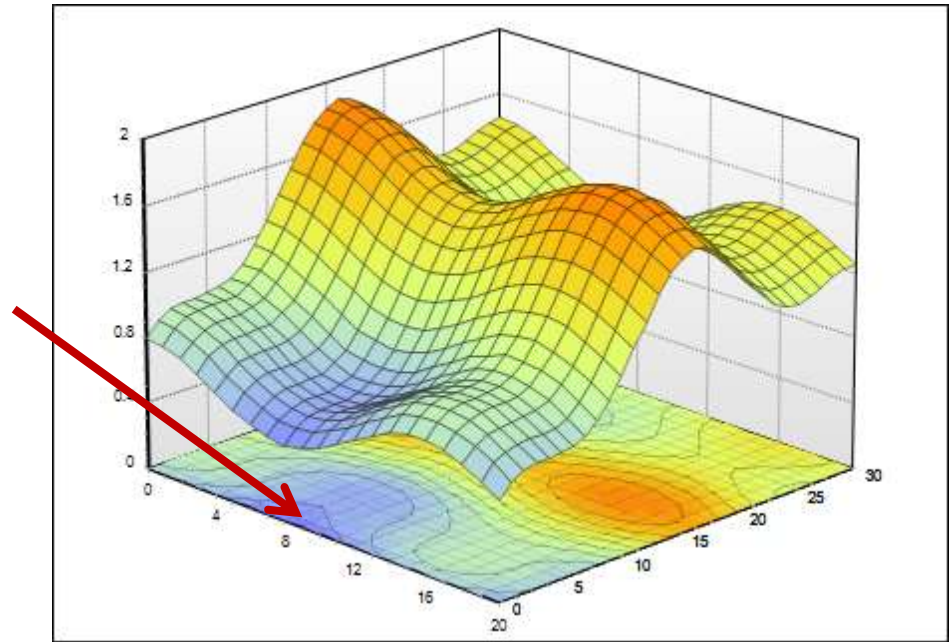
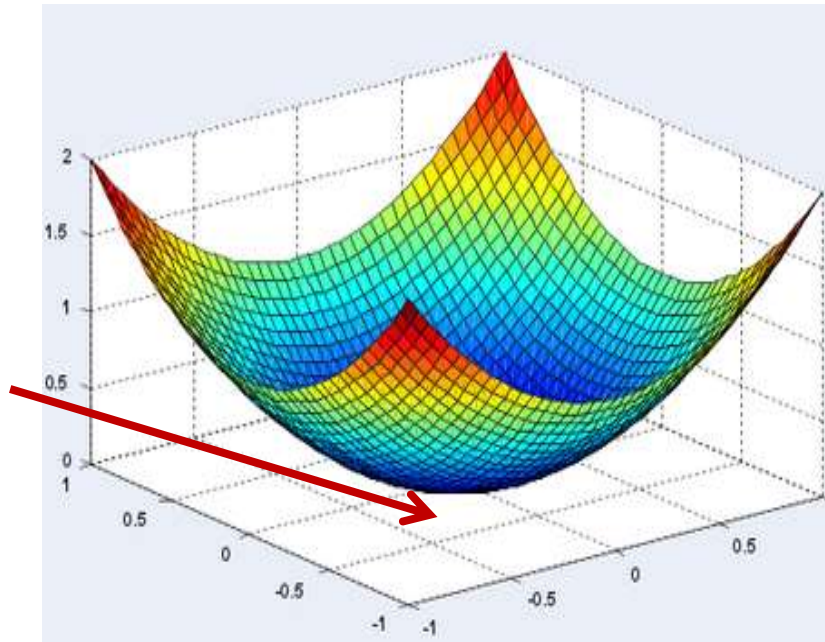

- The optimum point is still “turning” point
 - Shifting in any direction will increase the value
 - For smooth functions, miniscule shifts will not result in any change at all
- We must find a point where shifting in any direction by a microscopic amount will not change the value of the function

A brief note on derivatives of multivariate functions

The *Gradient* of a scalar function

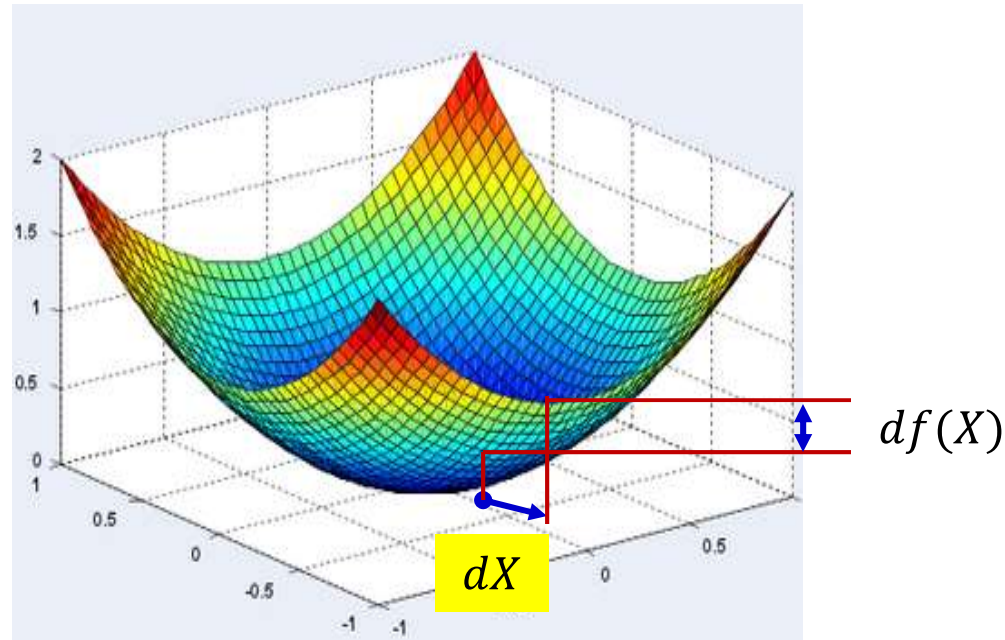

- The *derivative* $\nabla_X f(X)$ of a scalar function $f(X)$ of a multi-variate input X is a multiplicative factor that gives us the change in $f(X)$ for tiny variations in X

$$df(X) = \nabla_X f(X) dX$$

- The **gradient** is the transpose of the derivative $\nabla_X f(X)^T$

Gradients of scalar functions with multi-variate inputs

- Consider $f(X) = f(x_1, x_2, \dots, x_n)$

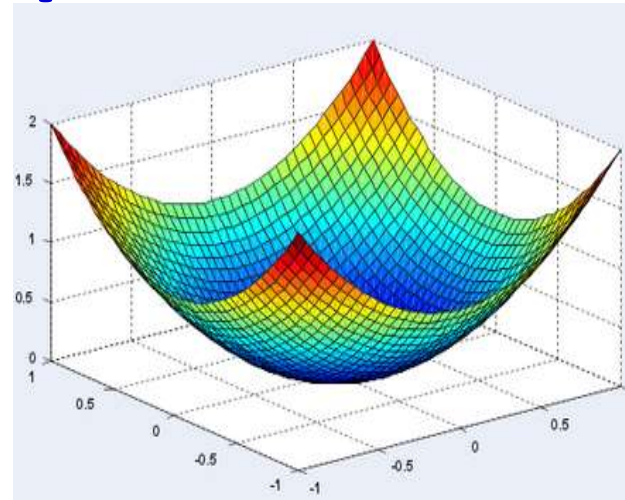

$$\nabla_X f(X) = \left[\frac{\partial f(X)}{\partial x_1} \quad \frac{\partial f(X)}{\partial x_2} \quad \dots \quad \frac{\partial f(X)}{\partial x_n} \right]$$

- Relation:

$$\begin{aligned} df(X) &= \nabla_X f(X) dX \\ &= \frac{\partial f(X)}{\partial x_1} dx_1 + \frac{\partial f(X)}{\partial x_2} dx_2 + \dots + \frac{\partial f(X)}{\partial x_n} dx_n \end{aligned}$$

Gradients of scalar functions with multi-variate inputs

- Consider $f(X) = f(x_1, x_2, \dots, x_n)$

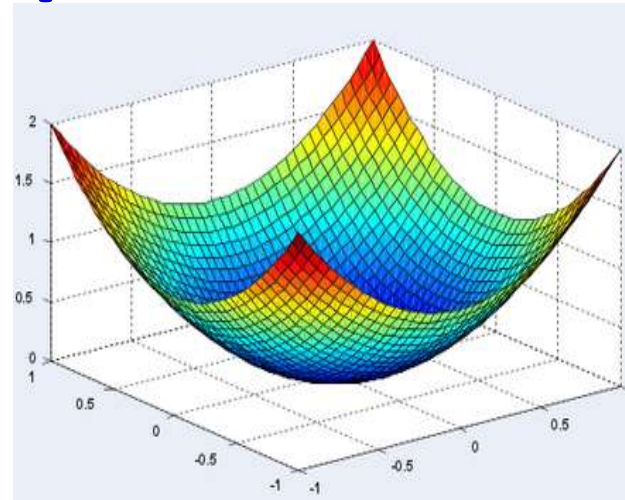

$$\nabla_X f(X) = \left[\frac{\partial f(X)}{\partial x_1} \quad \frac{\partial f(X)}{\partial x_2} \quad \dots \quad \frac{\partial f(X)}{\partial x_n} \right]$$

- Relation:

$$df(X) = \nabla_X f(X) dX$$

This is a vector inner product. To understand its behavior lets consider a well-known property of inner products

A well-known vector property

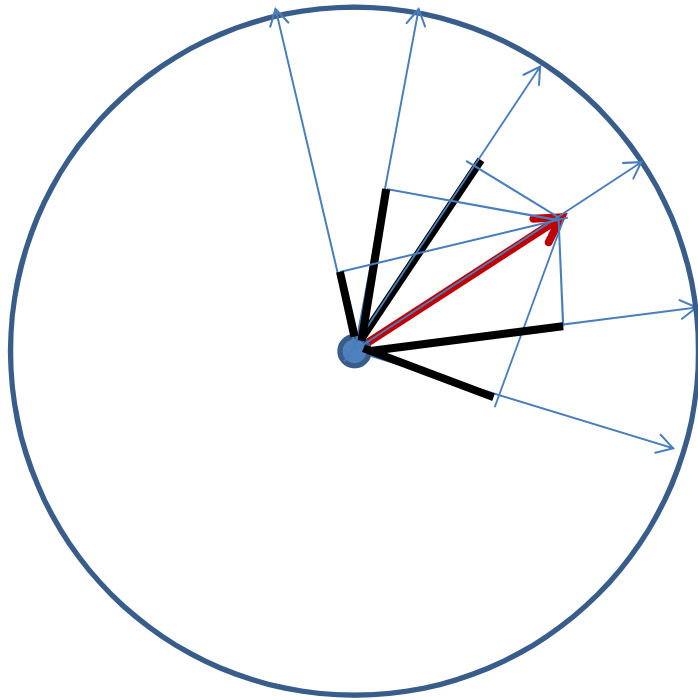

$$\mathbf{u}^T \mathbf{v} = |\mathbf{u}| |\mathbf{v}| \cos \theta$$

- The inner product between two vectors of fixed lengths is maximum when the two vectors are aligned
 - i.e. when $\theta = 0$

Properties of Gradient

- $df(X) = \nabla_X f(X) dX$
 - The inner product between $\nabla_X f(X)^T$ and dX
- Fixing the length of dX
 - E.g. $|dX| = 1$
- $df(X)$ is max if dX is aligned with $\nabla_X f(X)^T$
 - $\angle(\nabla_X f(X)^T, dX) = 0$
 - The function $f(X)$ increases most rapidly if the input increment dX is perfectly aligned to $\nabla_X f(X)^T$
- **The gradient is the direction of fastest increase in $f(X)$**

Gradient

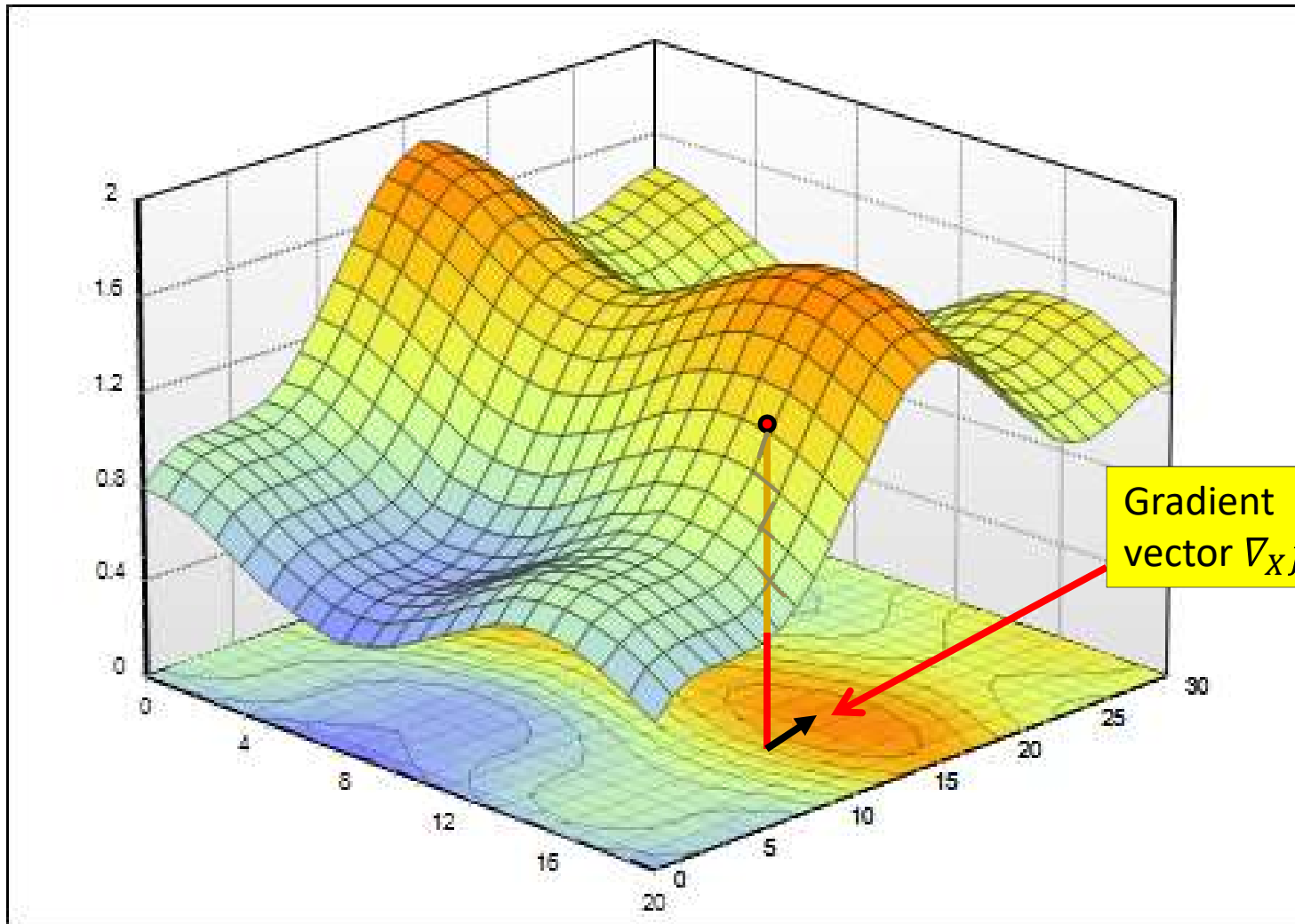

Gradient

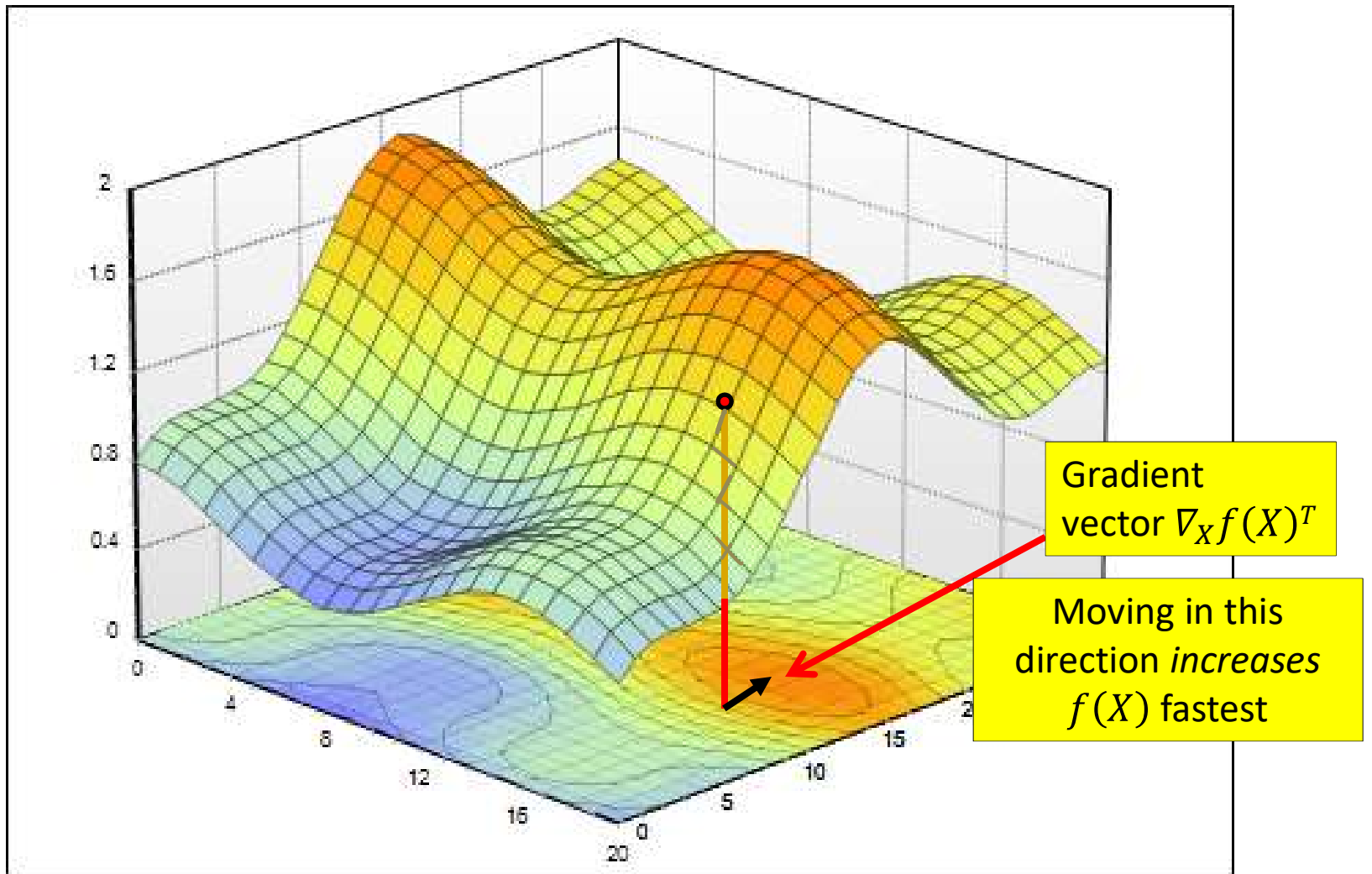

Gradient

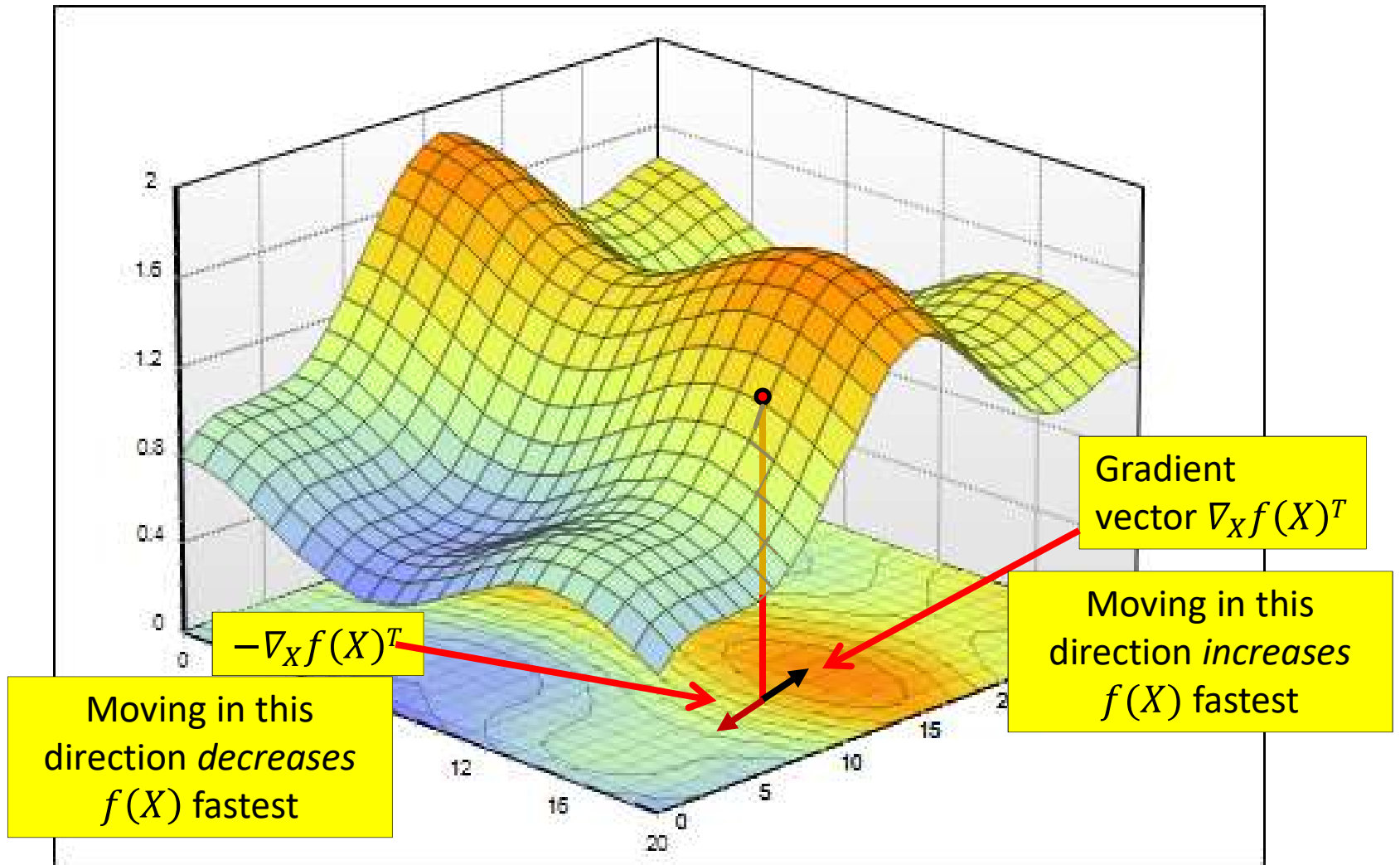

Gradient

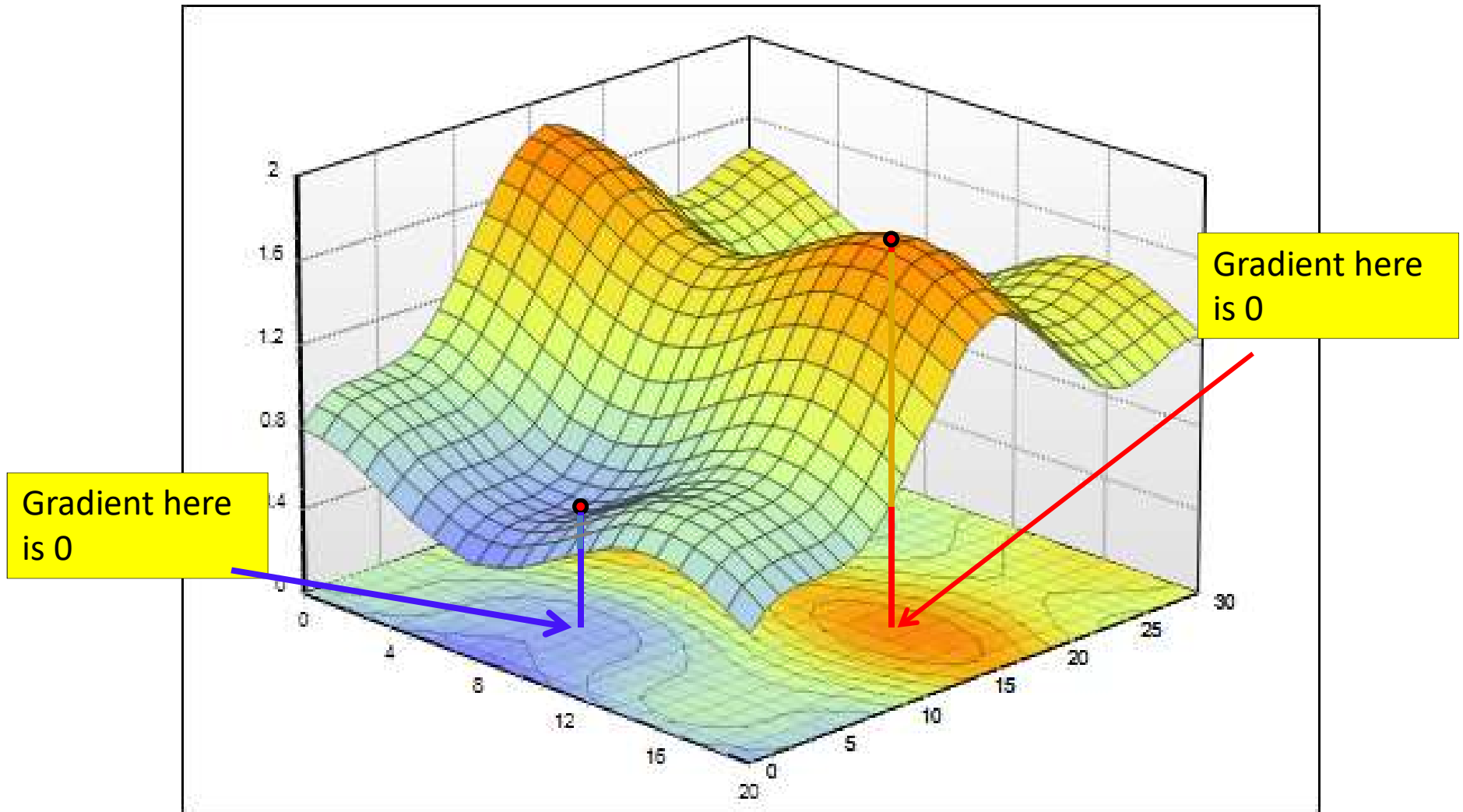

Properties of Gradient: 2

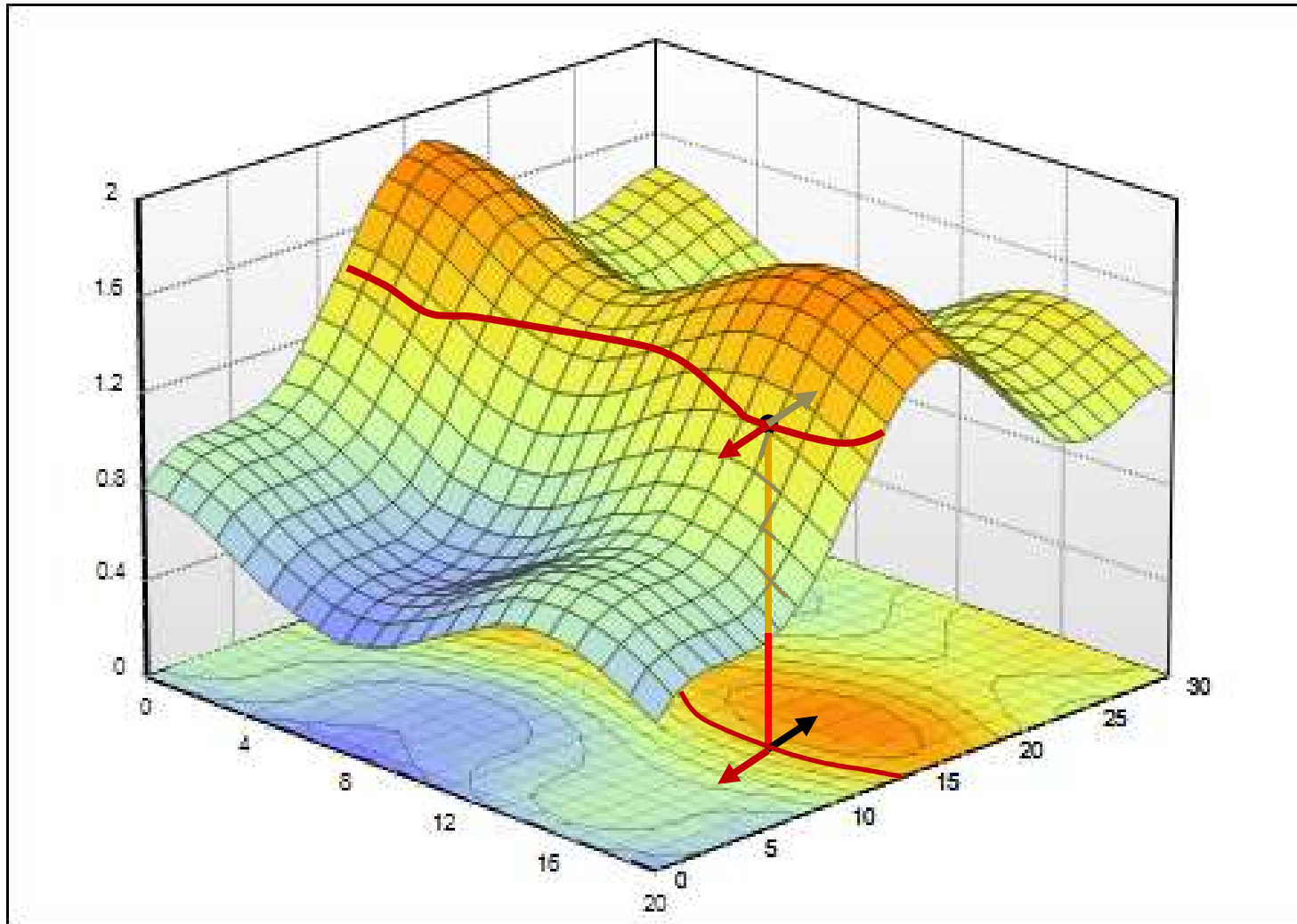

- The gradient vector $\nabla_X f(X)^T$ is perpendicular to the level curve

The Hessian

- The Hessian of a function $f(x_1, x_2, \dots, x_n)$ is given by the second derivative

$$\nabla_x^2 f(x_1, \dots, x_n) := \begin{bmatrix} \frac{\partial^2 f}{\partial x_1^2} & \frac{\partial^2 f}{\partial x_1 \partial x_2} & \cdot & \cdot & \frac{\partial^2 f}{\partial x_1 \partial x_n} \\ \frac{\partial^2 f}{\partial x_2 \partial x_1} & \frac{\partial^2 f}{\partial x_2^2} & \cdot & \cdot & \frac{\partial^2 f}{\partial x_2 \partial x_n} \\ \cdot & \cdot & \cdot & \cdot & \cdot \\ \frac{\partial^2 f}{\partial x_n \partial x_1} & \frac{\partial^2 f}{\partial x_n \partial x_2} & \cdot & \cdot & \frac{\partial^2 f}{\partial x_n^2} \end{bmatrix}$$

Returning to direct optimization...

Finding the minimum of a scalar function of a multi-variate input

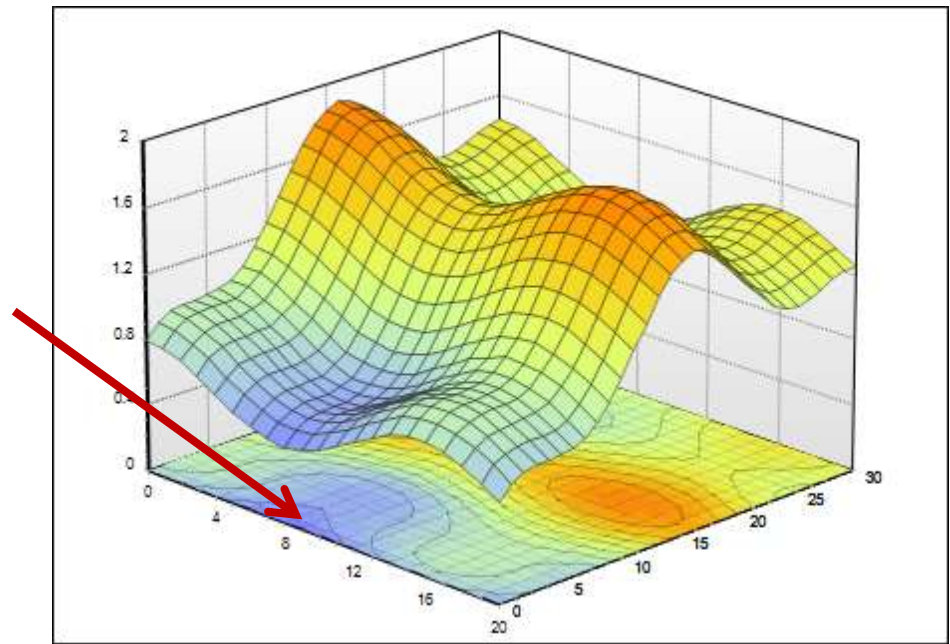
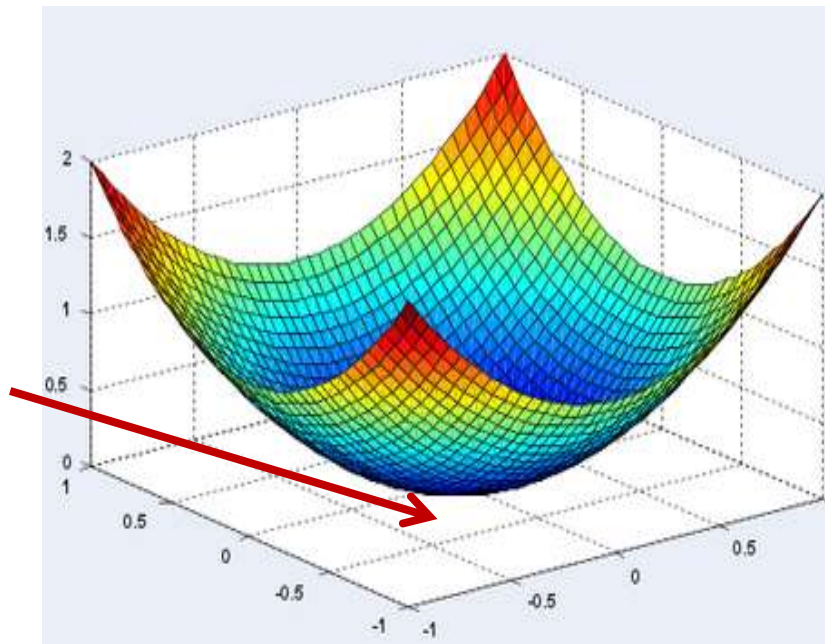

- The optimum point is a turning point – the gradient will be 0

Unconstrained Minimization of function (Multivariate)

1. Solve for the X where the derivative (or gradient) equals to zero

$$\nabla_X f(X) = 0$$

2. Compute the Hessian Matrix $\nabla_X^2 f(X)$ at the candidate solution and verify that
 - Hessian is positive definite (eigenvalues positive) -> to identify local minima
 - Hessian is negative definite (eigenvalues negative) -> to identify local maxima

Unconstrained Minimization of function (Example)

- Minimize

$$f(x_1, x_2, x_3) = (x_1)^2 + x_1(1 - x_2) + (x_2)^2 - x_2x_3 + (x_3)^2 + x_3$$

- Gradient

$$\nabla_X f^T = \begin{bmatrix} 2x_1 + 1 - x_2 \\ -x_1 + 2x_2 - x_3 \\ -x_2 + 2x_3 + 1 \end{bmatrix}$$

Unconstrained Minimization of function (Example)

- Set the gradient to null

$$\nabla_x f = 0 \Rightarrow \begin{bmatrix} 2x_1 + 1 - x_2 \\ -x_1 + 2x_2 - x_3 \\ -x_2 + 2x_3 + 1 \end{bmatrix} = \begin{bmatrix} 0 \\ 0 \\ 0 \end{bmatrix}$$

- Solving the 3 equations system with 3 unknowns

$$x = \begin{bmatrix} x_1 \\ x_2 \\ x_3 \end{bmatrix} = \begin{bmatrix} -1 \\ -1 \\ -1 \end{bmatrix}$$

Unconstrained Minimization of function (Example)

- Compute the Hessian matrix $\nabla_x^2 f = \begin{bmatrix} 2 & -1 & 0 \\ -1 & 2 & -1 \\ 0 & -1 & 2 \end{bmatrix}$

- Evaluate the eigenvalues of the Hessian matrix

$$\lambda_1 = 3.414, \quad \lambda_2 = 0.586, \quad \lambda_3 = 2$$

- All the eigenvalues are positives \Rightarrow the Hessian matrix is positive definite

- The point $x = \begin{bmatrix} x_1 \\ x_2 \\ x_3 \end{bmatrix} = \begin{bmatrix} -1 \\ -1 \\ -1 \end{bmatrix}$ is a minimum

Closed Form Solutions are not always available

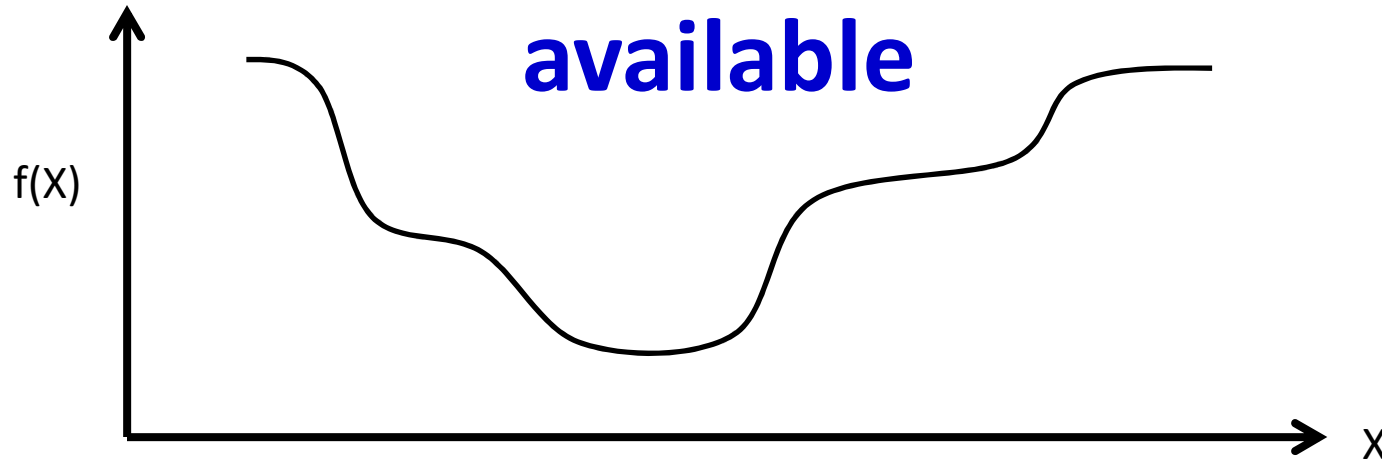

- Often it is not possible to simply solve $\nabla_x f(X) = 0$
 - The function to minimize/maximize may have an intractable form
- In these situations, iterative solutions are used
 - Begin with a “guess” for the optimal X and refine it iteratively until the correct value is obtained

Iterative solutions

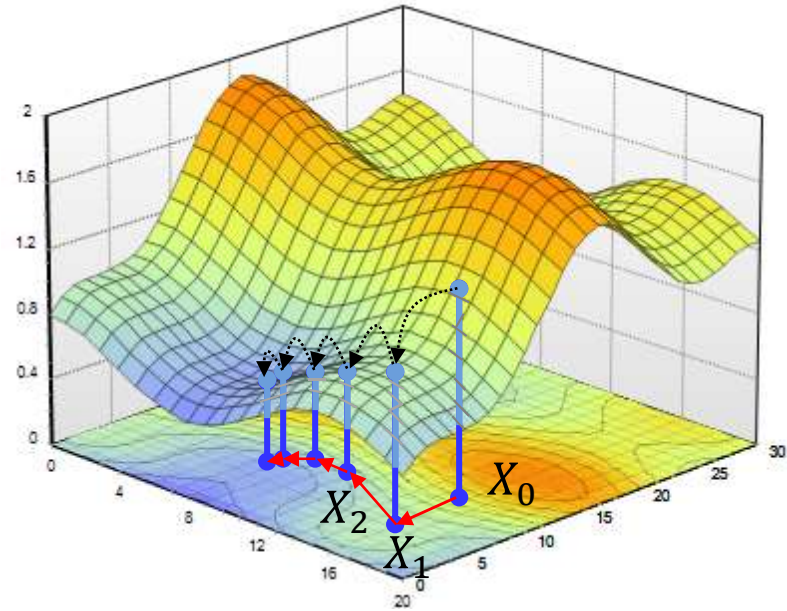
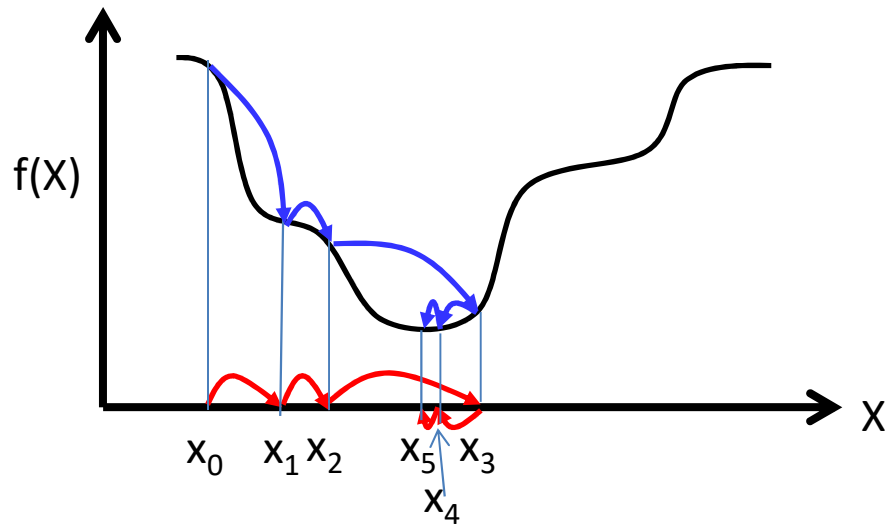

- Iterative solutions
 - Start from an initial guess X_0 for the optimal X
 - Update the guess towards a (hopefully) “better” value of $f(X)$
 - Stop when $f(X)$ no longer decreases
- Problems:
 - Which direction to step in
 - How big must the steps be

The Approach of Gradient Descent

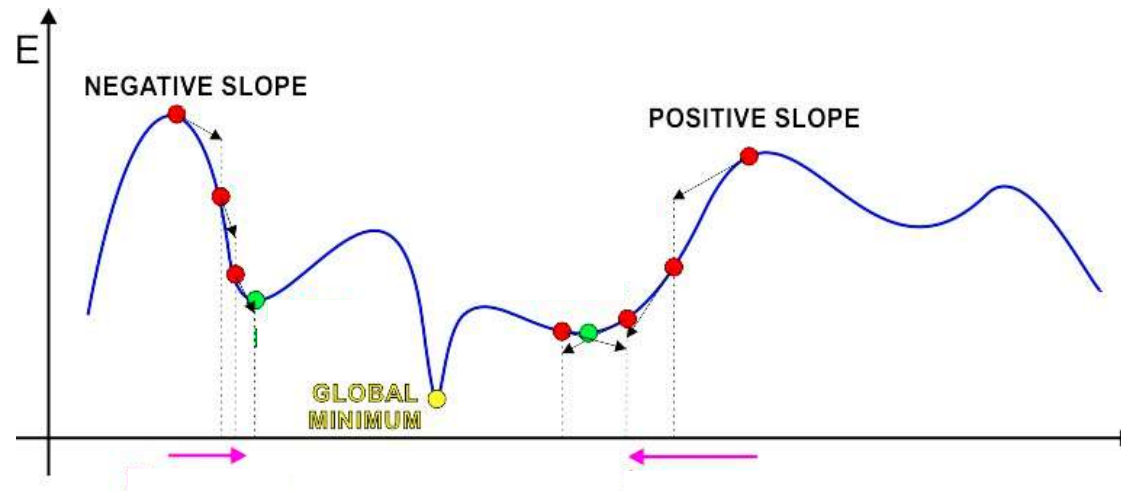

- Iterative solution:
 - Start at some point
 - Find direction in which to shift this point to decrease error
 - This can be found from the derivative of the function
 - A positive derivative \rightarrow moving left decreases error
 - A negative derivative \rightarrow moving right decreases error
 - Shift point in this direction

The Approach of Gradient Descent

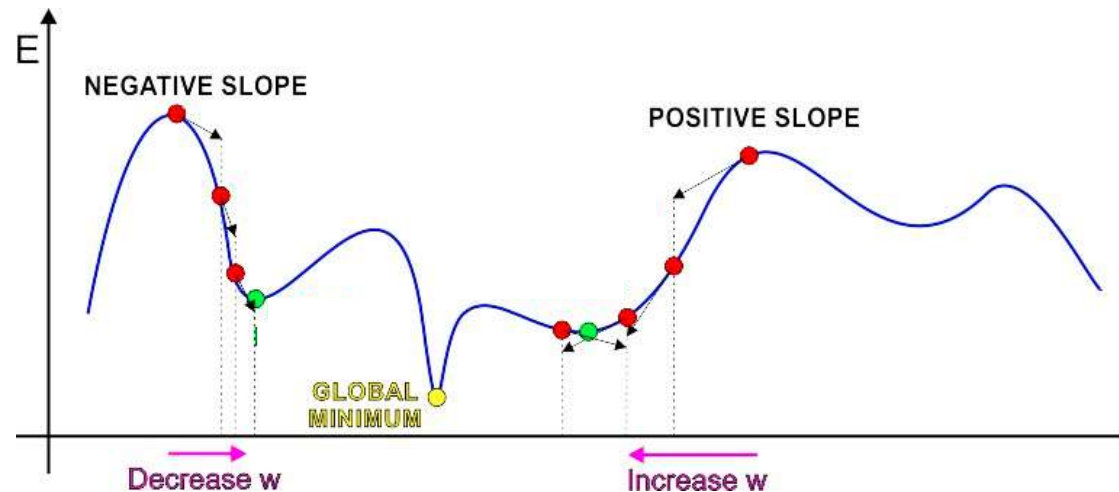

- Iterative solution: Trivial algorithm
 - Initialize x^0
 - While $f'(x^k) \neq 0$
 - If $\text{sign}(f'(x^k))$ is positive:
$$x^{k+1} = x^k - \text{step}$$
 - Else
$$x^{k+1} = x^k + \text{step}$$
- What must step be to ensure we actually get to the optimum?

The Approach of Gradient Descent

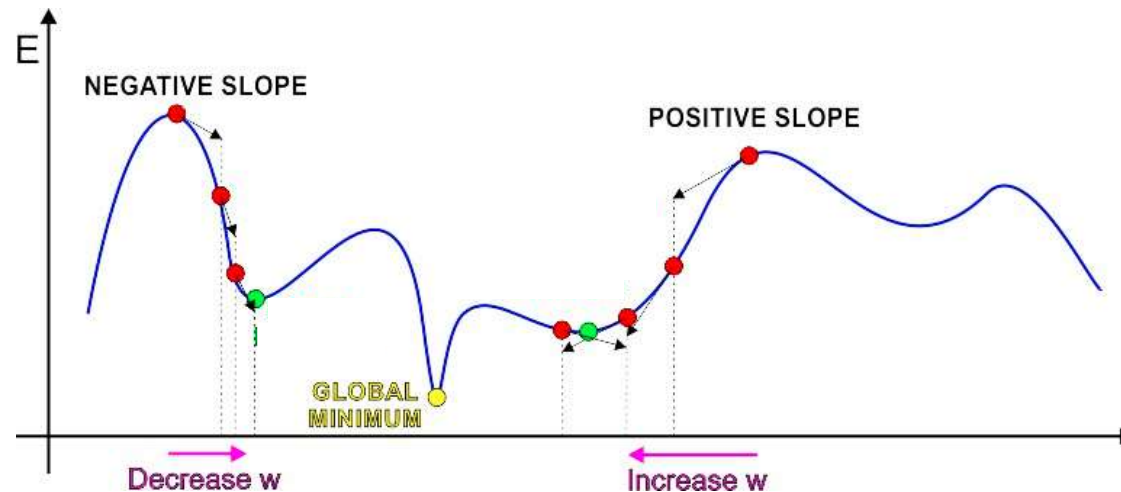

- Iterative solution: Trivial algorithm

- Initialize x^0
- While $f'(x^k) \neq 0$

$$x^{k+1} = x^k - \text{sign}(f'(x^k)) \cdot \text{step}$$

- Identical to previous algorithm

The Approach of Gradient Descent

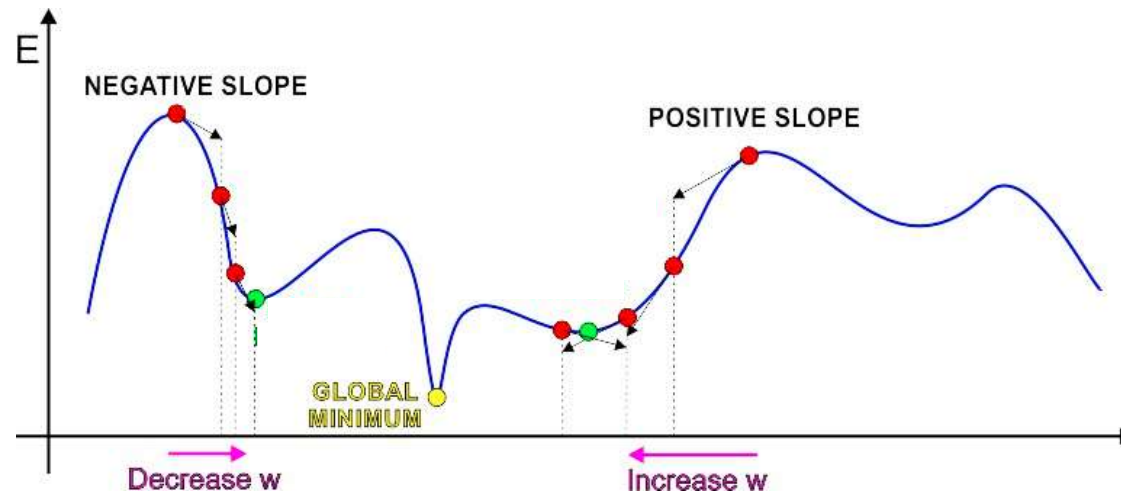

- Iterative solution: Trivial algorithm
 - Initialize x^0
 - While $f'(x^k) \neq 0$
$$x^{k+1} = x^k - \eta^k f'(x^k)$$
- η^k is the “step size”

Gradient descent/ascent (multivariate)

- The gradient descent/ascent method to find the minimum or maximum of a function f iteratively
 - To find a *maximum* move *in the direction of the gradient*

$$x^{k+1} = x^k + \eta^k \nabla_x f(x^k)^T$$

- To find a *minimum* move *exactly opposite the direction of the gradient*

$$x^{k+1} = x^k - \eta^k \nabla_x f(x^k)^T$$

- Many solutions to choosing step size η^k

1. Fixed step size

- Fixed step size
 - Use fixed value for η^k

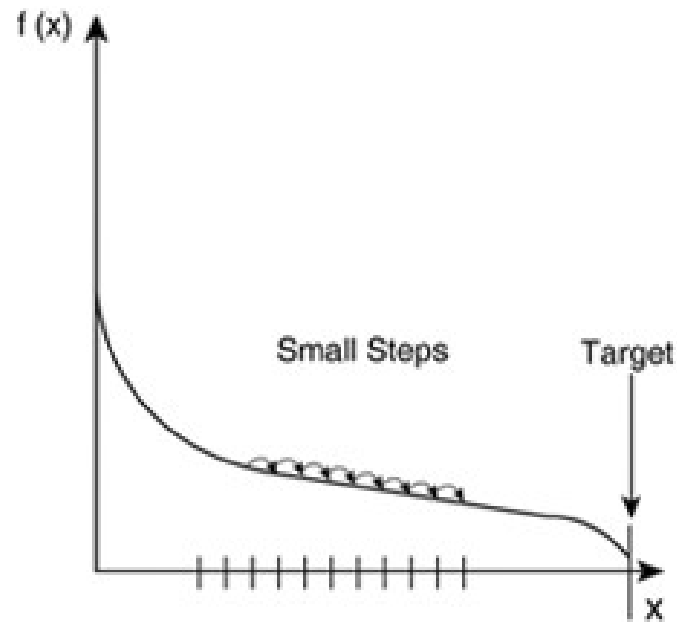

Influence of step size example (constant step size)

$$f(x_1, x_2) = (x_1)^2 + x_1 x_2 + 4(x_2)^2$$

$$x^{initial} = \begin{bmatrix} 3 \\ 3 \end{bmatrix}$$

$$\eta = 0.1$$

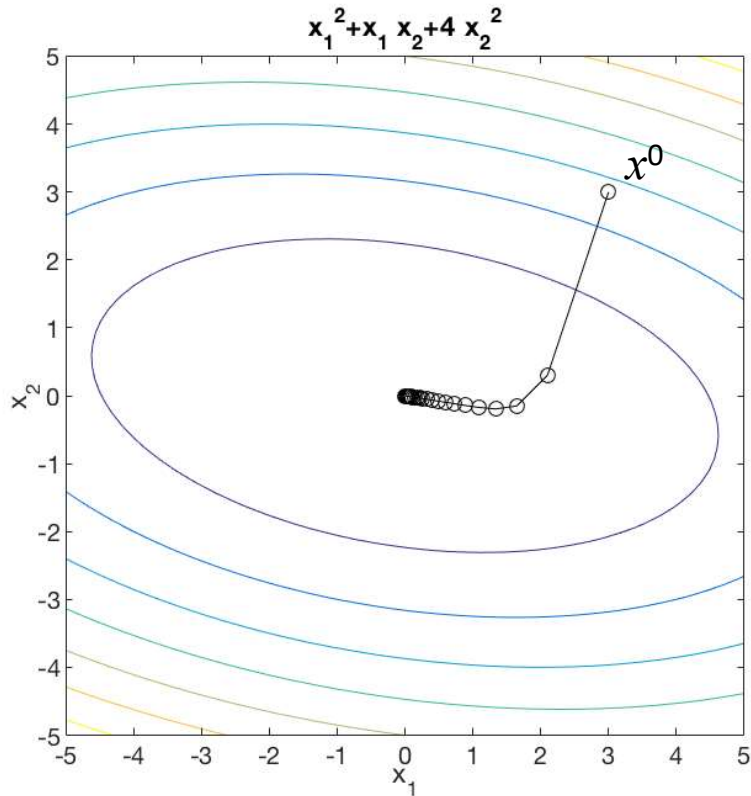

$$\eta = 0.2$$

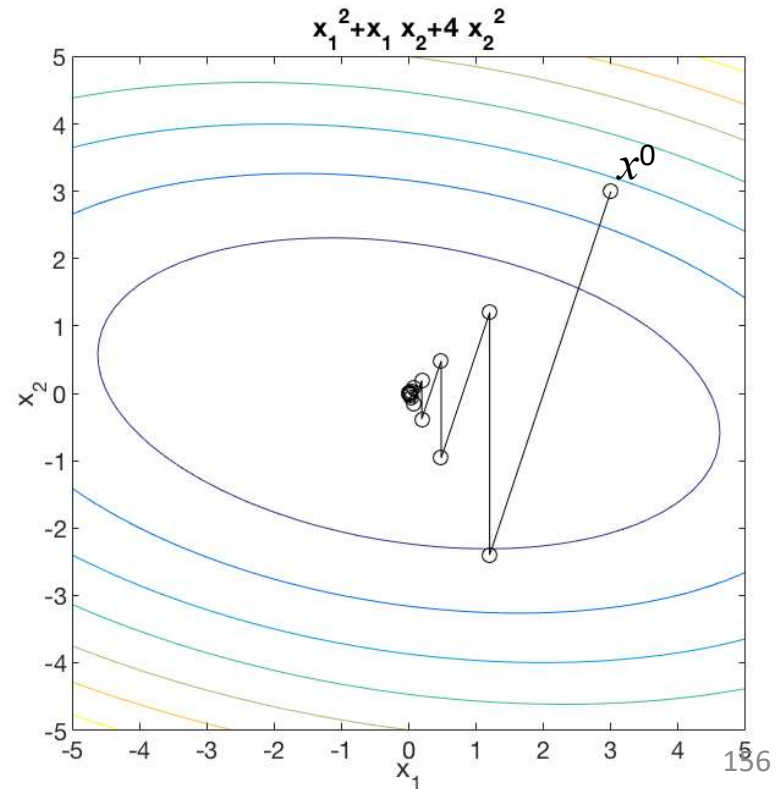

What is the optimal step size?

- Step size is critical for fast optimization
- Will revisit this topic later
- For now, simply assume a potentially-iteration-dependent step size

Gradient descent convergence criteria

- The gradient descent algorithm converges when one of the following criteria is satisfied

$$|f(x^{k+1}) - f(x^k)| < \varepsilon_1$$

- Or

$$\|\nabla_x f(x^k)\| < \varepsilon_2$$

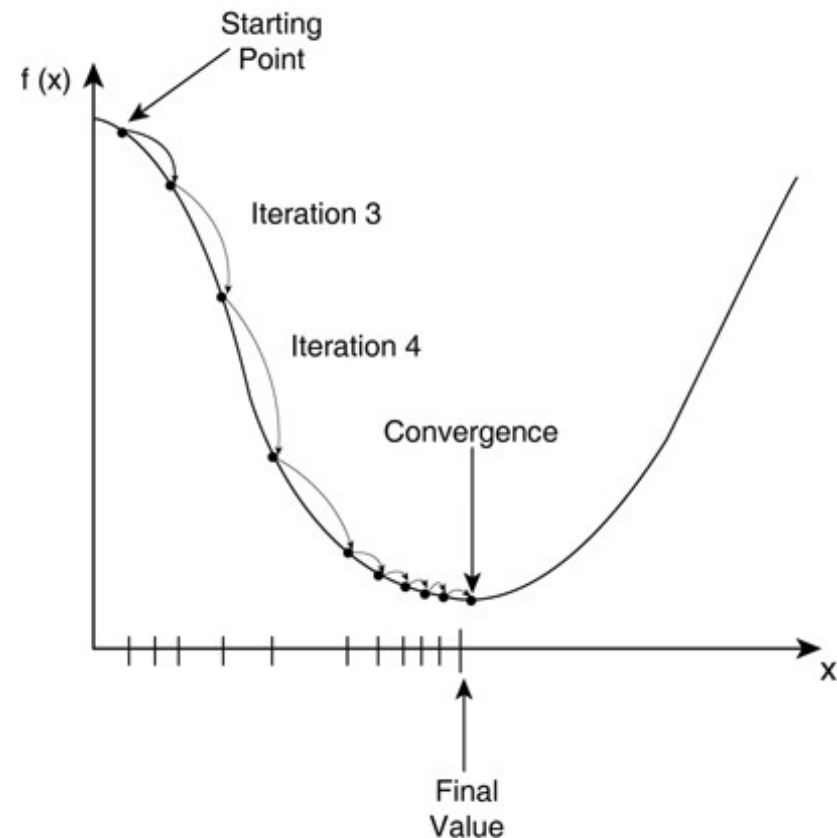

Overall Gradient Descent Algorithm

- Initialize:
 - x^0
 - $k = 0$
- do
 - $x^{k+1} = x^k - \eta^k \nabla_x f(x^k)^T$
 - $k = k + 1$
- while $|f(x^{k+1}) - f(x^k)| > \varepsilon$

Next up

- Gradient descent to train neural networks
- A.K.A. Back propagation