

Neural Networks

Representations
Spring 2025

Attendance: @1054

Story so far

- Neural nets are universal approximators
 - They can model any Boolean, categorical or real-valued function
- They can check static inputs for patterns
- They can scan for patterns
- They can analyze time series for patterns

- They must be *trained* to make their predictions

- But what do they learn *internally*?
 - What does the network actually represent?

Learning in the net

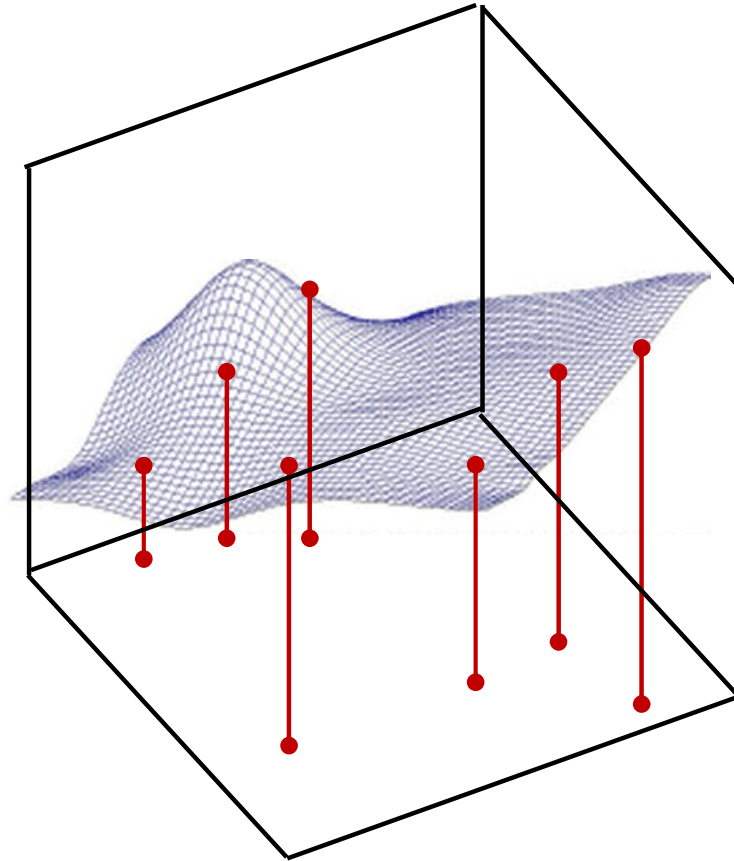

- Problem: Given a collection of input-output pairs, learn the function

Learning for classification

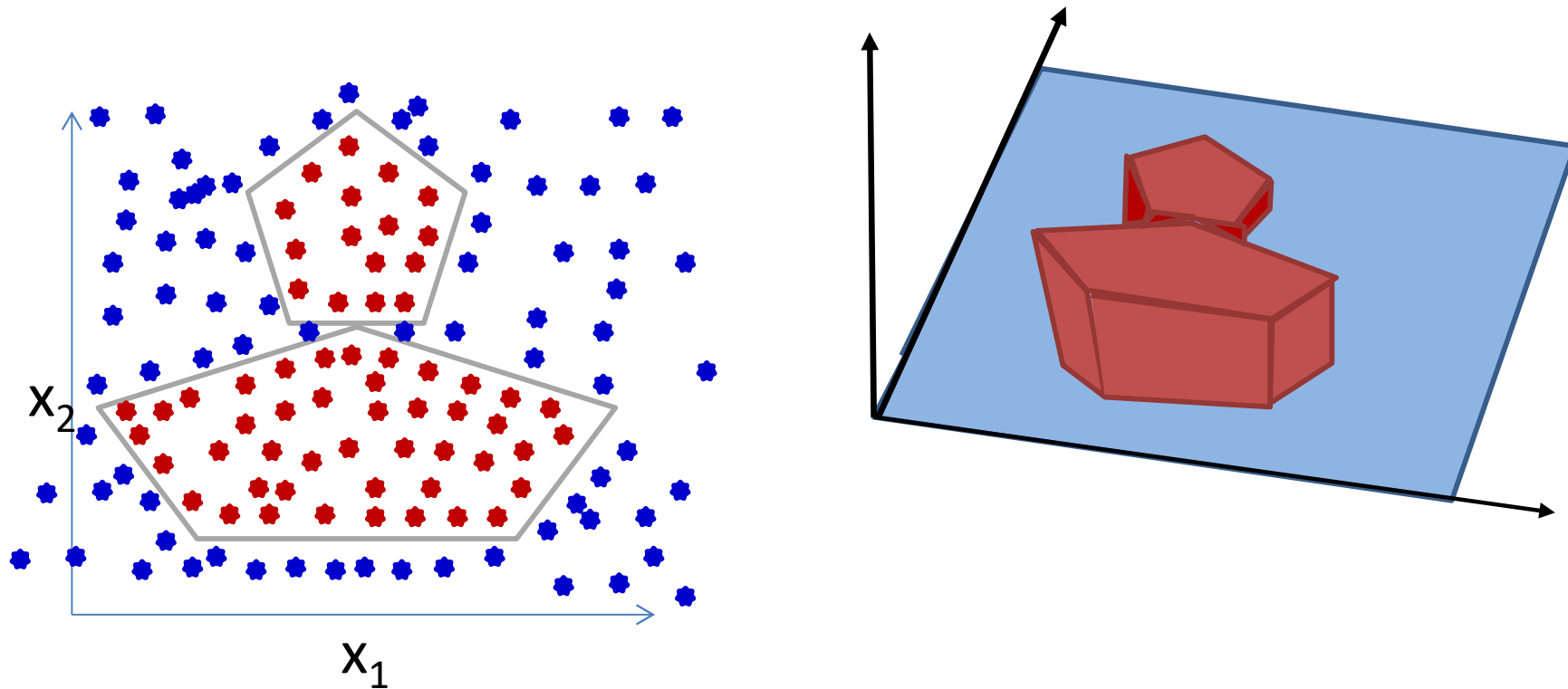

- When the net must learn to classify..
 - Learn the classification boundaries that separate the training instances

Learning for classification

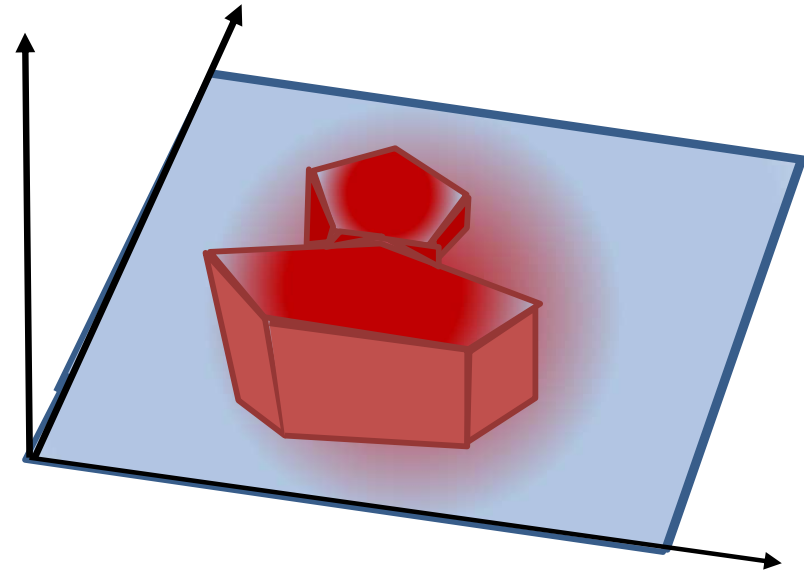
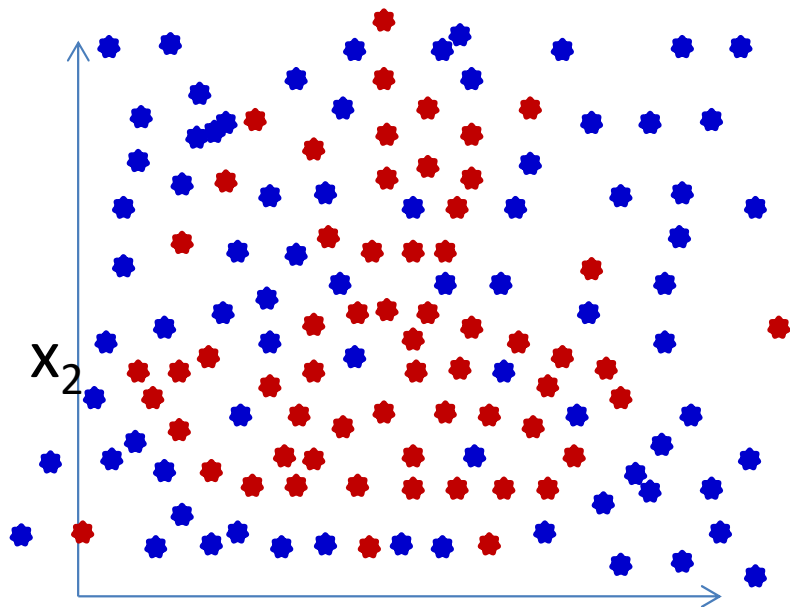

- In reality
 - In general, not really cleanly separated
 - So, what is the function we learn?

In reality: Trivial linear example

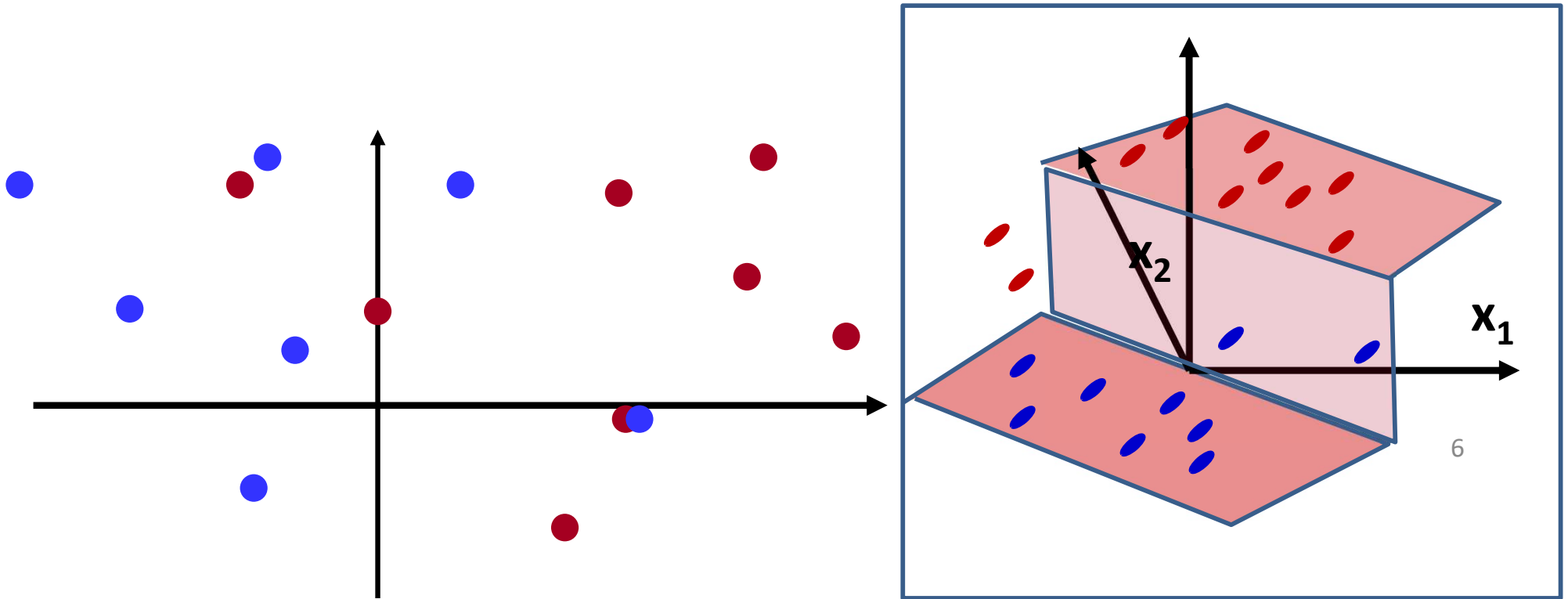

- Two-dimensional example
 - Blue dots (on the floor) on the “red” side
 - Red dots (suspended at $Y=1$) on the “blue” side
 - No line will cleanly separate the two colors

Non-linearly separable data: 1-D example

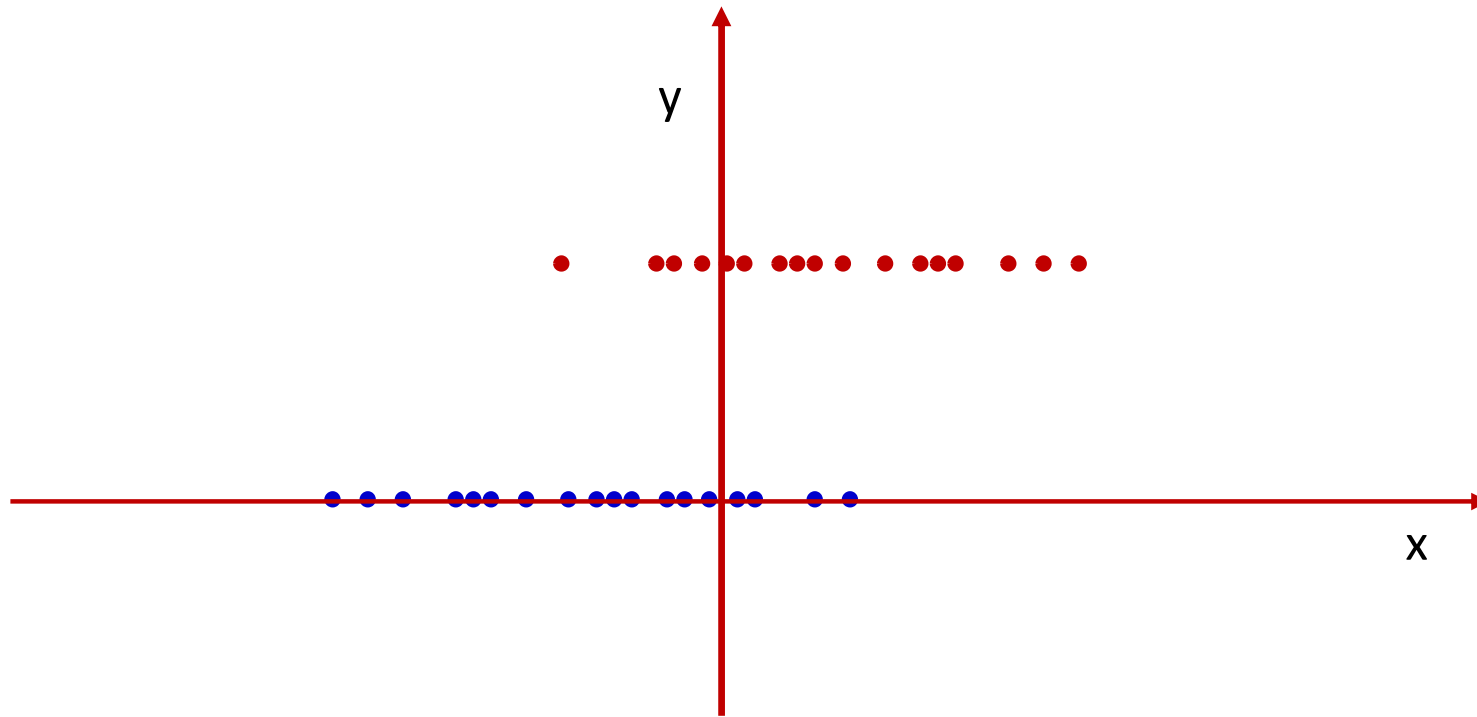

- One-dimensional example for visualization
 - All (red) dots at $Y=1$ represent instances of class $Y=1$
 - All (blue) dots at $Y=0$ are from class $Y=0$
 - The data are not linearly separable
 - In this 1-D example, a linear separator is a threshold
 - No threshold will cleanly separate red and blue dots

Undesired Function

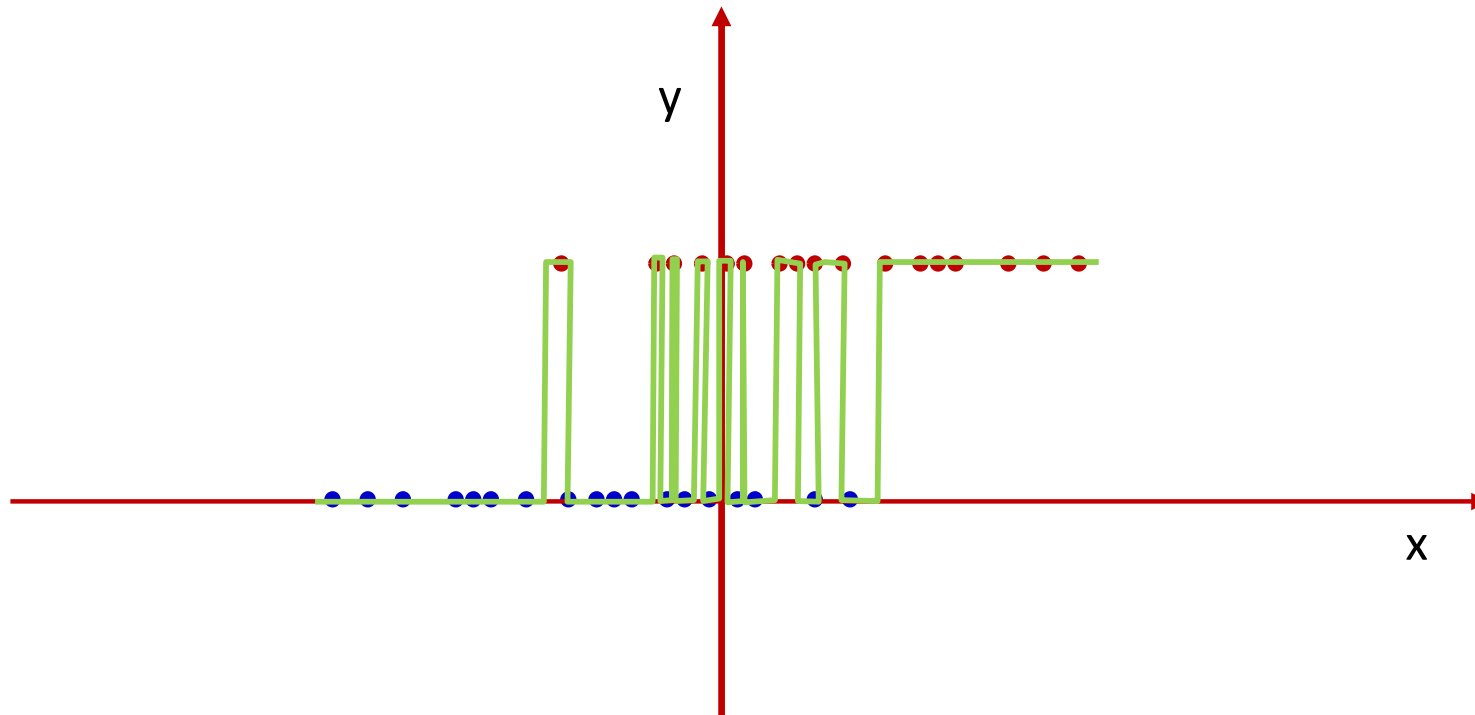

- One-dimensional example for visualization
 - All (red) dots at $Y=1$ represent instances of class $Y=1$
 - All (blue) dots at $Y=0$ are from class $Y=0$
 - The data are not linearly separable
 - In this 1-D example, a linear separator is a threshold
 - No threshold will cleanly separate red and blue dots

What if?

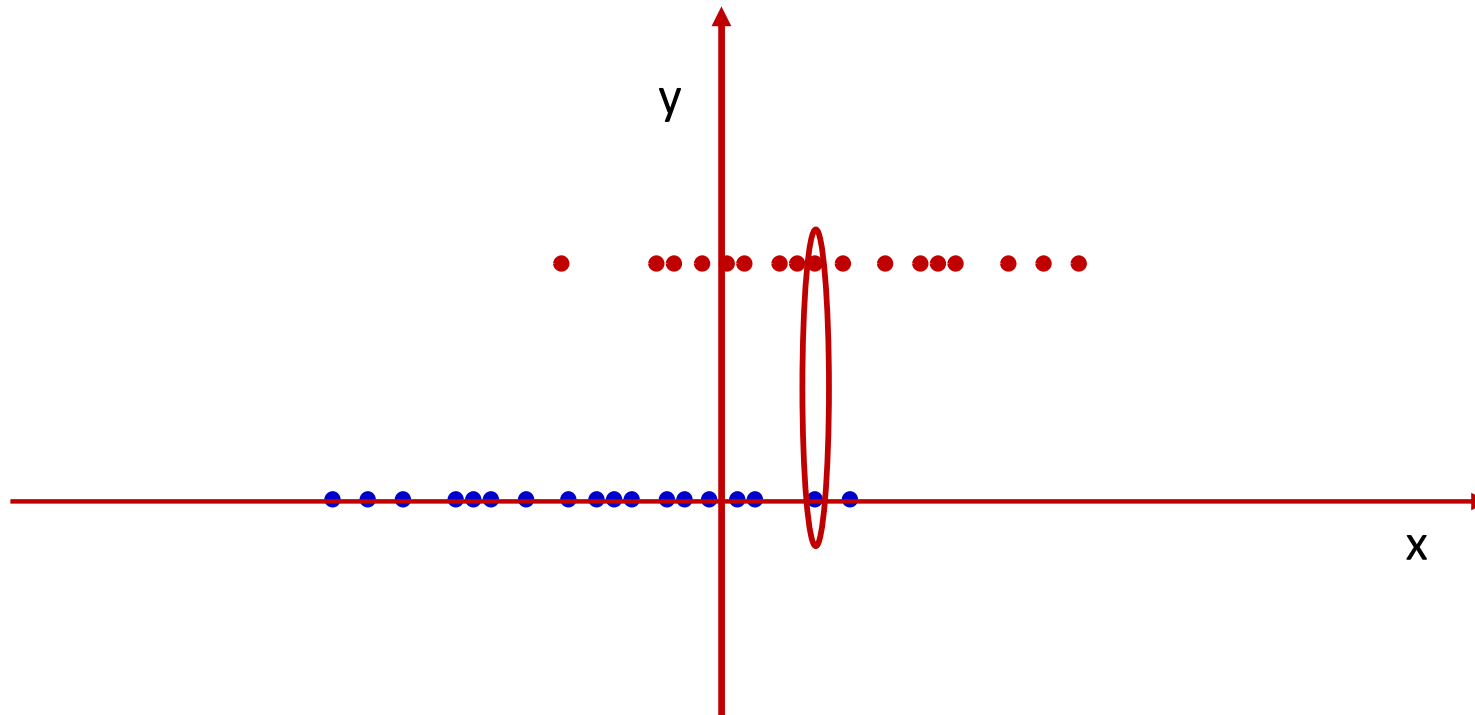

- One-dimensional example for visualization
 - All (red) dots at $Y=1$ represent instances of class $Y=1$
 - All (blue) dots at $Y=0$ are from class $Y=0$
 - The data are not linearly separable
 - In this 1-D example, a linear separator is a threshold
 - No threshold will cleanly separate red and blue dots

What if?

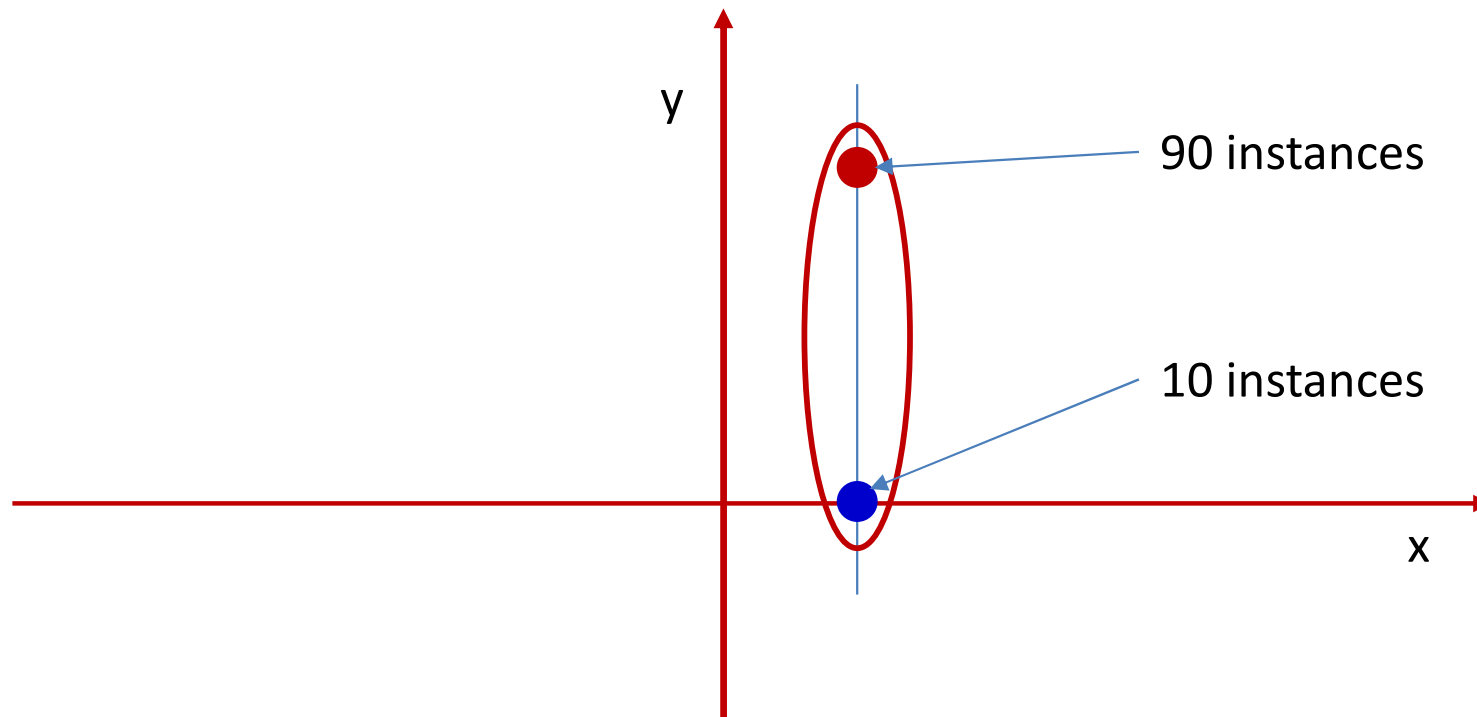

- What must the value of the function be at this x ?
 - 1 because red dominates?
 - 0.9 : The average?

What if?

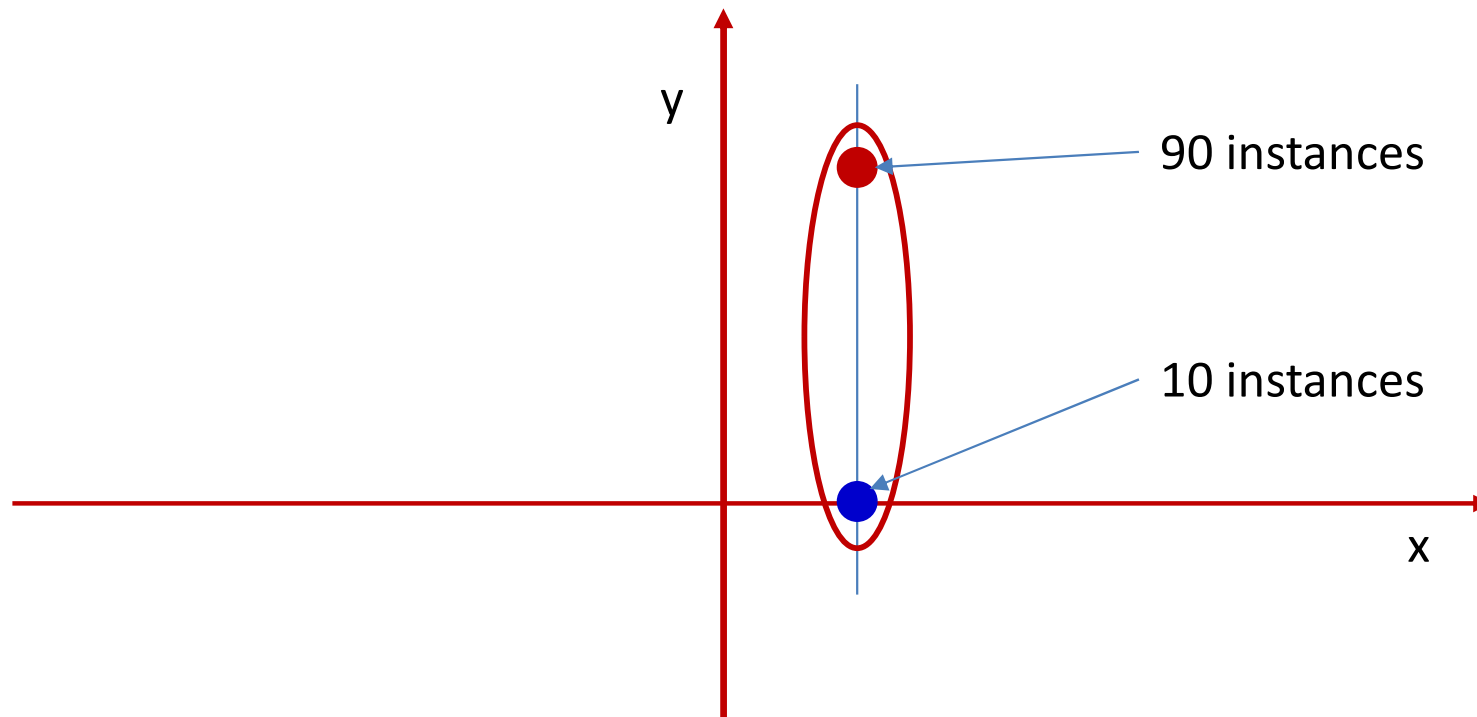

- What must the value of the function be at this X ?

- 1 because red dominates?
- 0.9 : The average?

Estimate: $\approx P(1|X)$

Potentially much more useful than a simple 1/0 decision
Also, potentially more realistic

What if?

Should an infinitesimal nudge of the red dot change the function estimate entirely?

If not, how do we estimate $P(1|X)$?
(since the positions of the red and blue X Values are different)

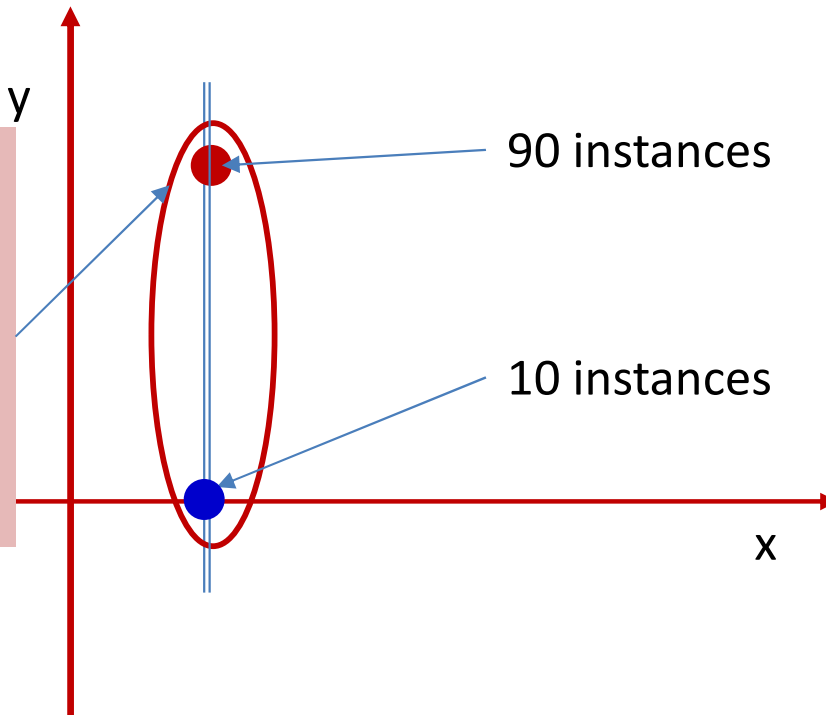

- What must the value of the function be at this X?

- 1 because red dominates?
- 0.9 : The average?

Estimate: $\approx P(1|X)$

Potentially much more useful than a simple 1/0 decision
Also, potentially more realistic

The *probability* of $y=1$

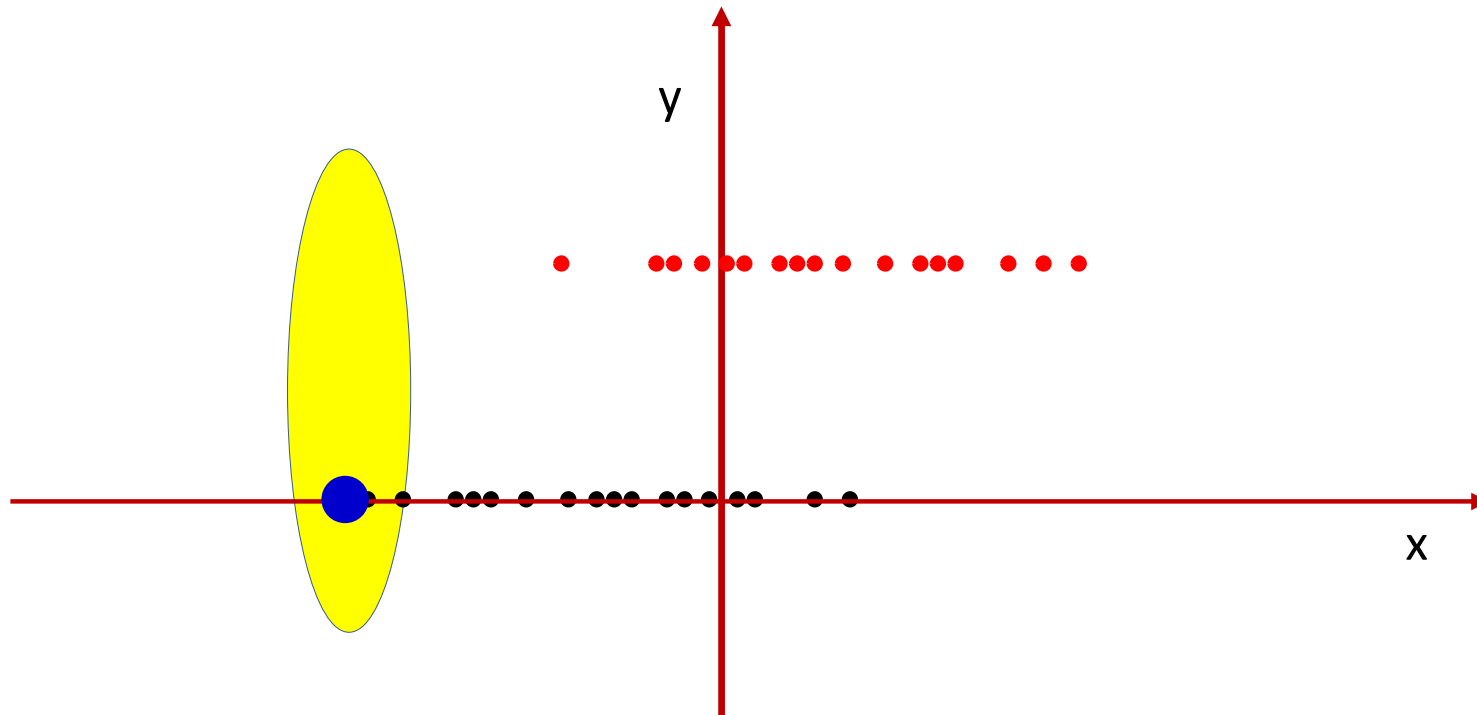

- Consider this differently: at each point look at a small window around that point
- Plot the average value within the window
 - This is an approximation of the *probability* of $Y=1$ at that point

The *probability* of $y=1$

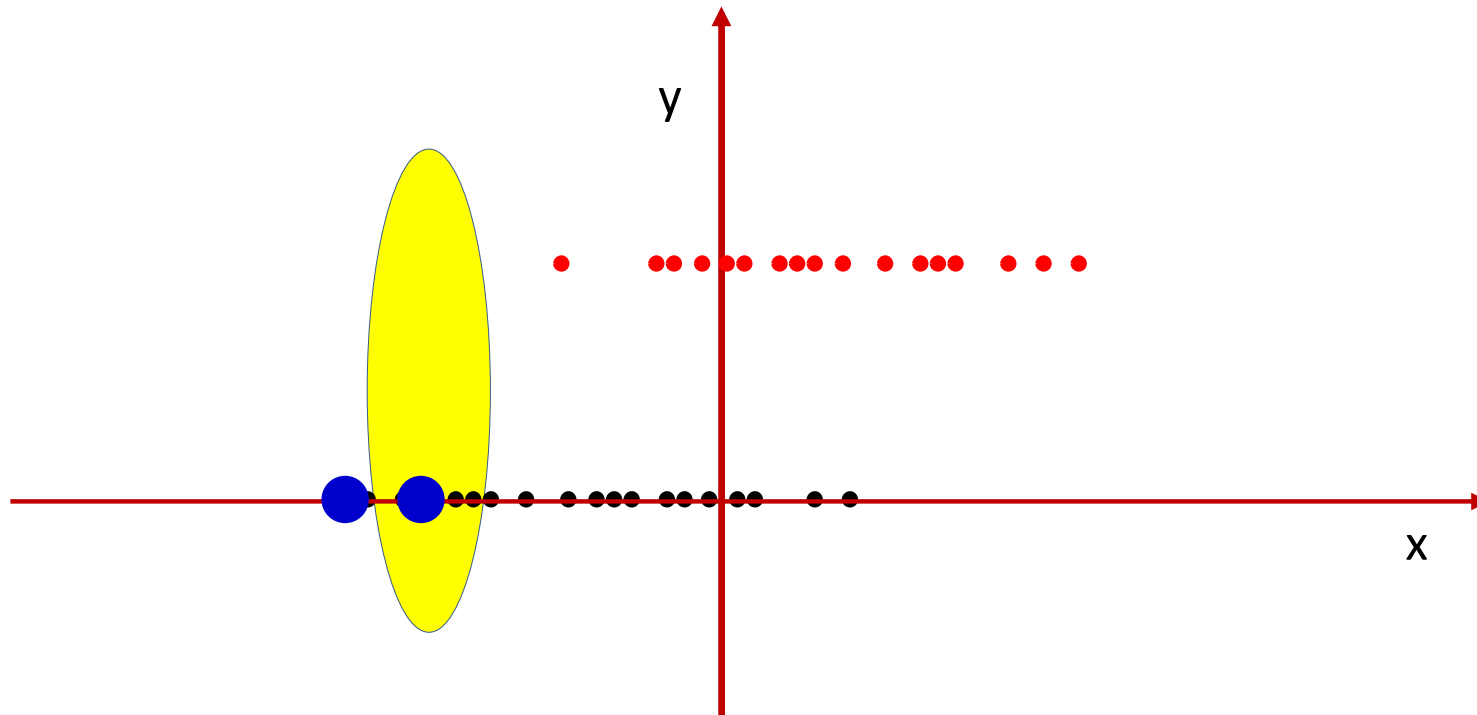

- Consider this differently: at each point look at a small window around that point
- Plot the average value within the window
 - This is an approximation of the *probability* of 1 at that point

The *probability* of $y=1$

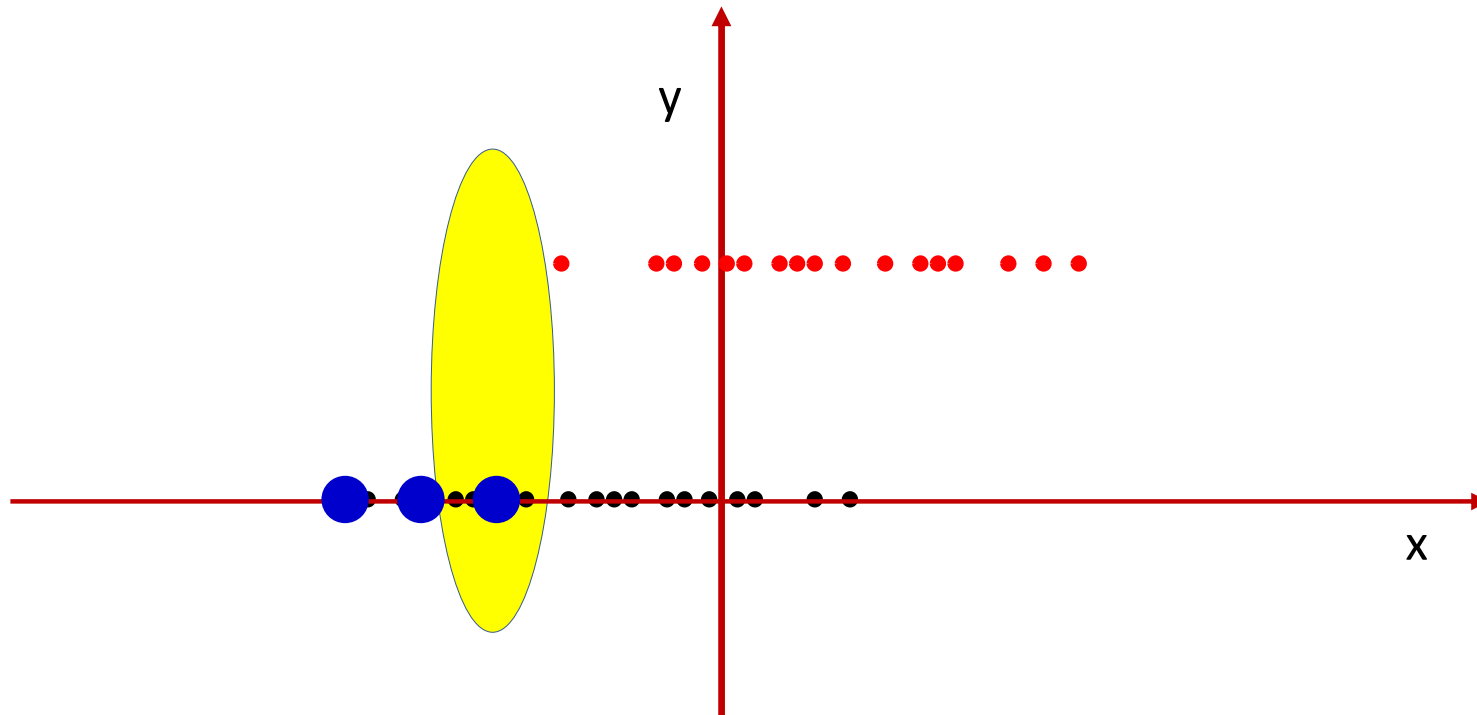

- Consider this differently: at each point look at a small window around that point
- Plot the average value within the window
 - This is an approximation of the *probability* of 1 at that point

The *probability* of $y=1$

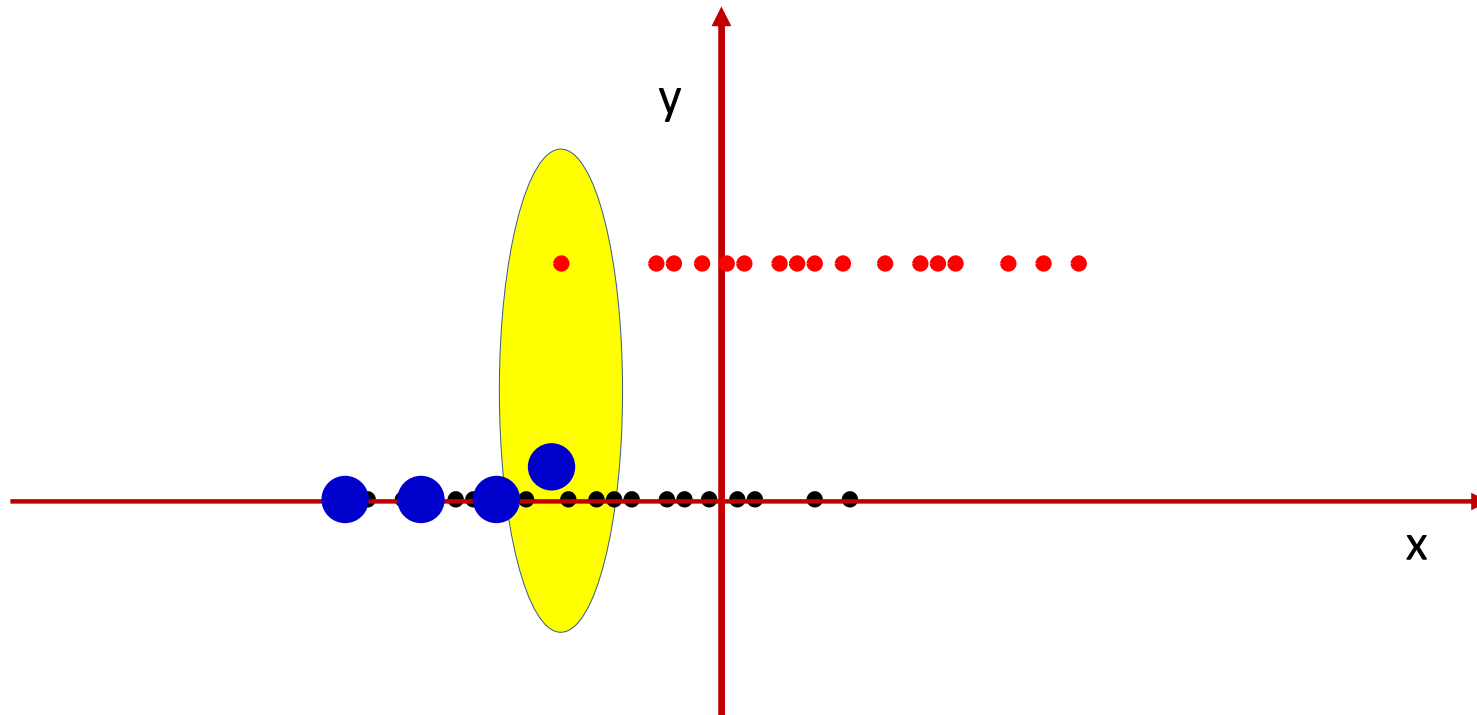

- Consider this differently: at each point look at a small window around that point
- Plot the average value within the window
 - This is an approximation of the *probability* of 1 at that point

The *probability* of $y=1$

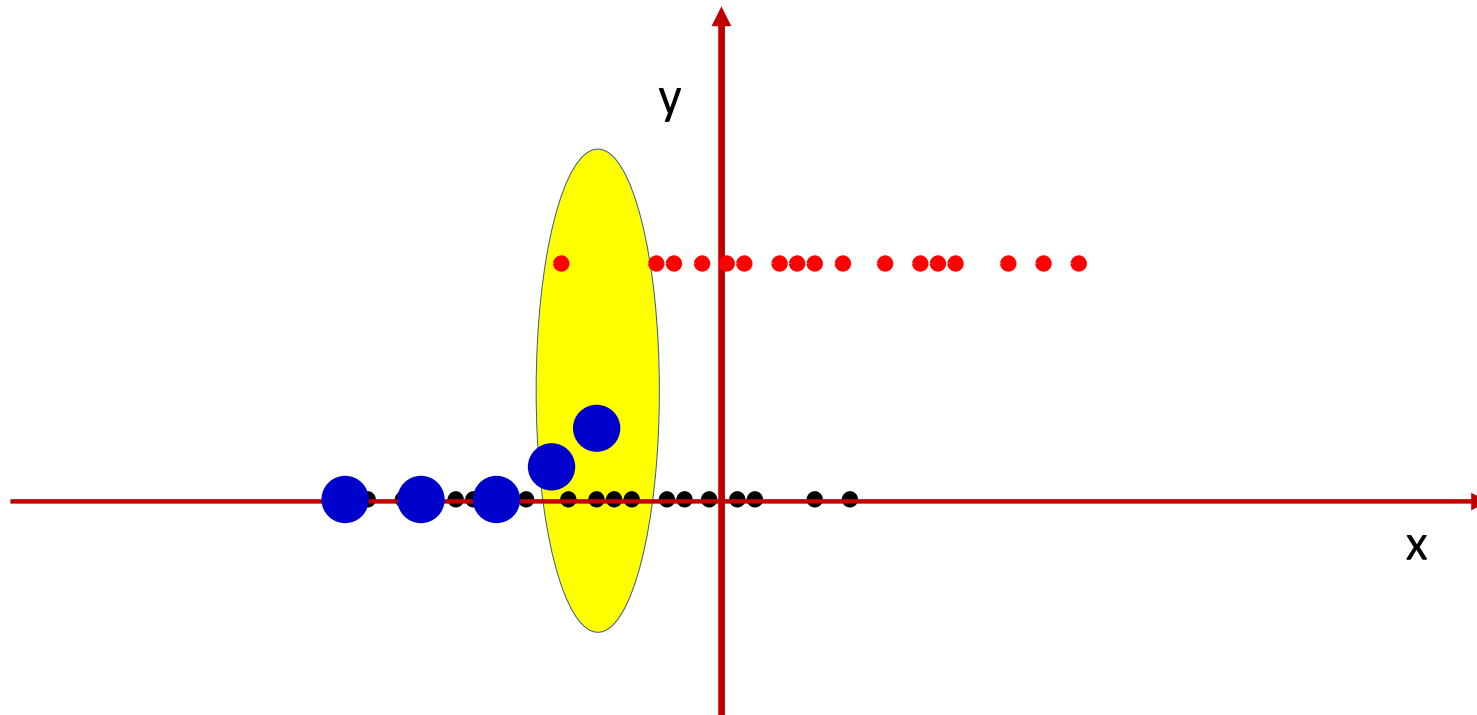

- Consider this differently: at each point look at a small window around that point
- Plot the average value within the window
 - This is an approximation of the *probability* of 1 at that point

The *probability* of $y=1$

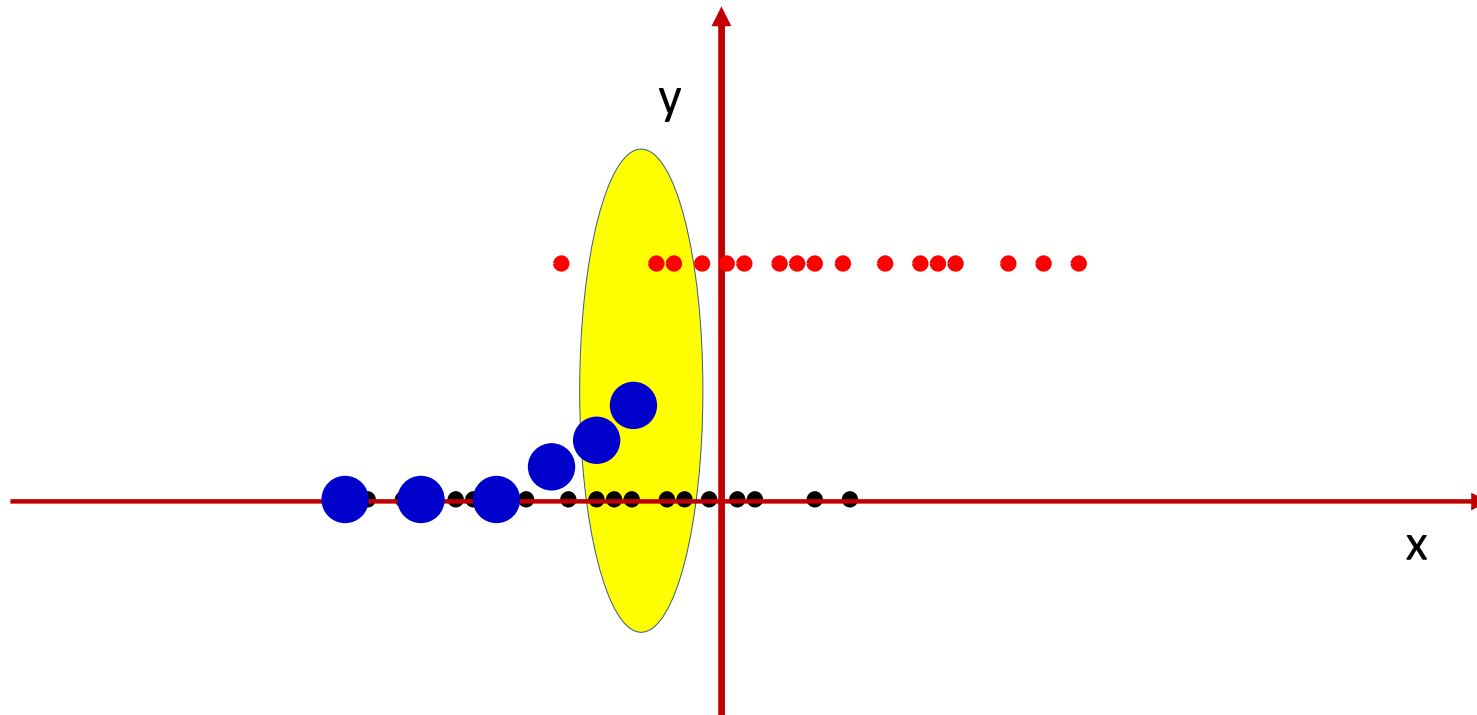

- Consider this differently: at each point look at a small window around that point
- Plot the average value within the window
 - This is an approximation of the *probability* of 1 at that point

The *probability* of $y=1$

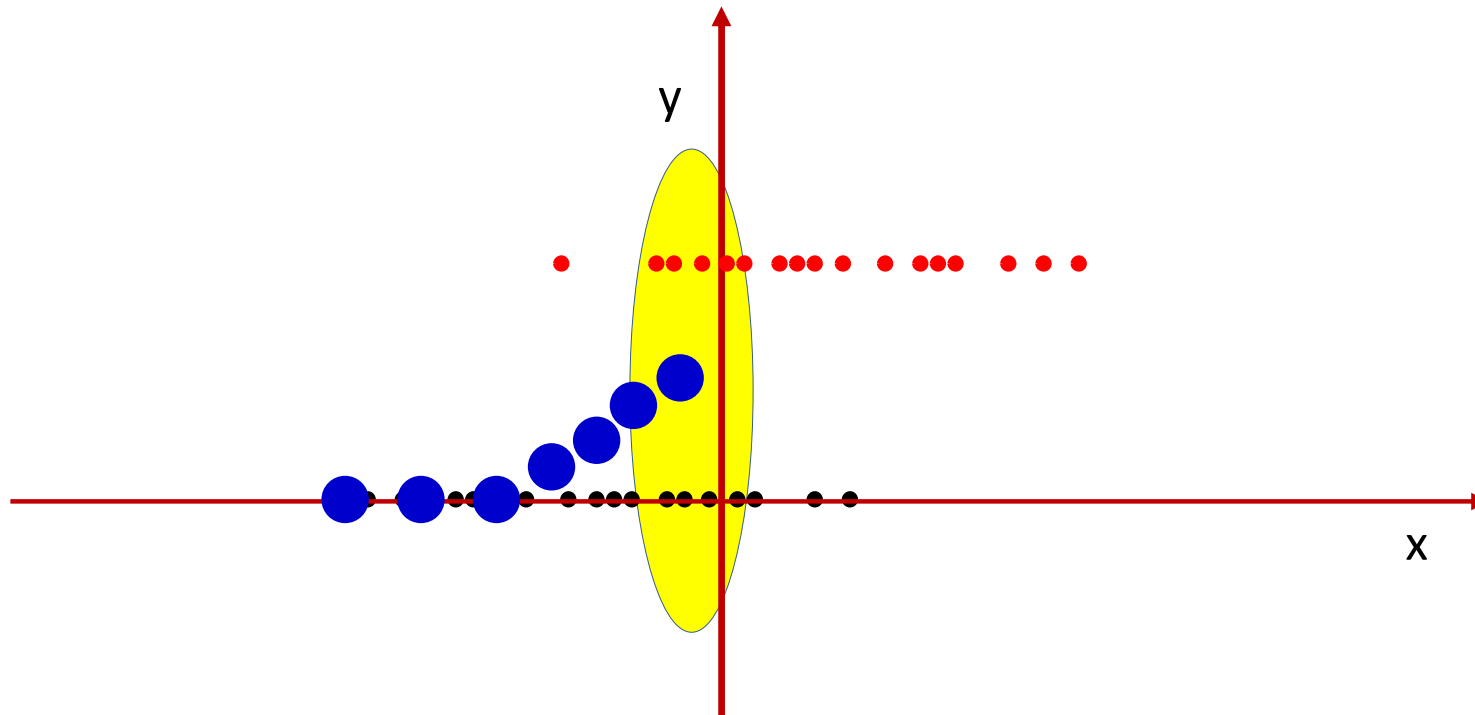

- Consider this differently: at each point look at a small window around that point
- Plot the average value within the window
 - This is an approximation of the *probability* of 1 at that point

The *probability* of $y=1$

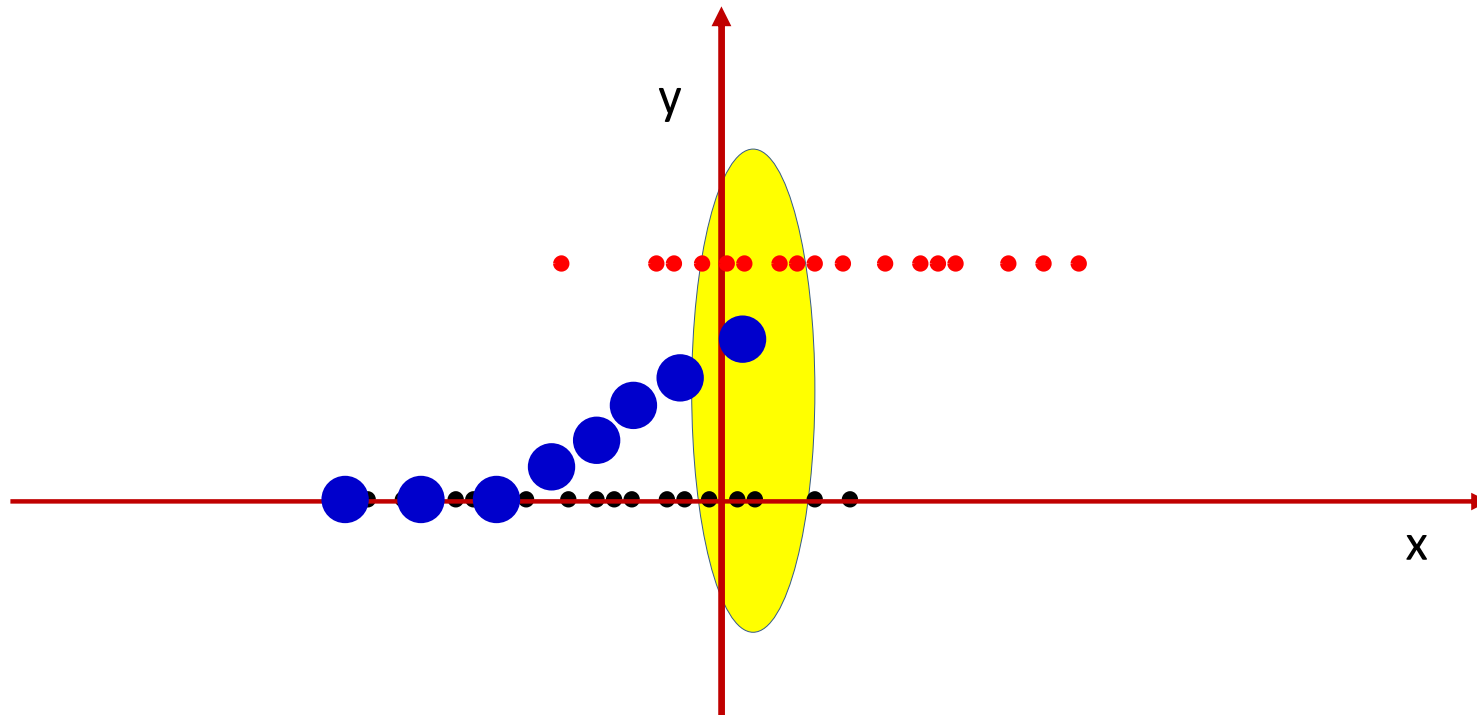

- Consider this differently: at each point look at a small window around that point
- Plot the average value within the window
 - This is an approximation of the *probability* of 1 at that point

The *probability* of $y=1$

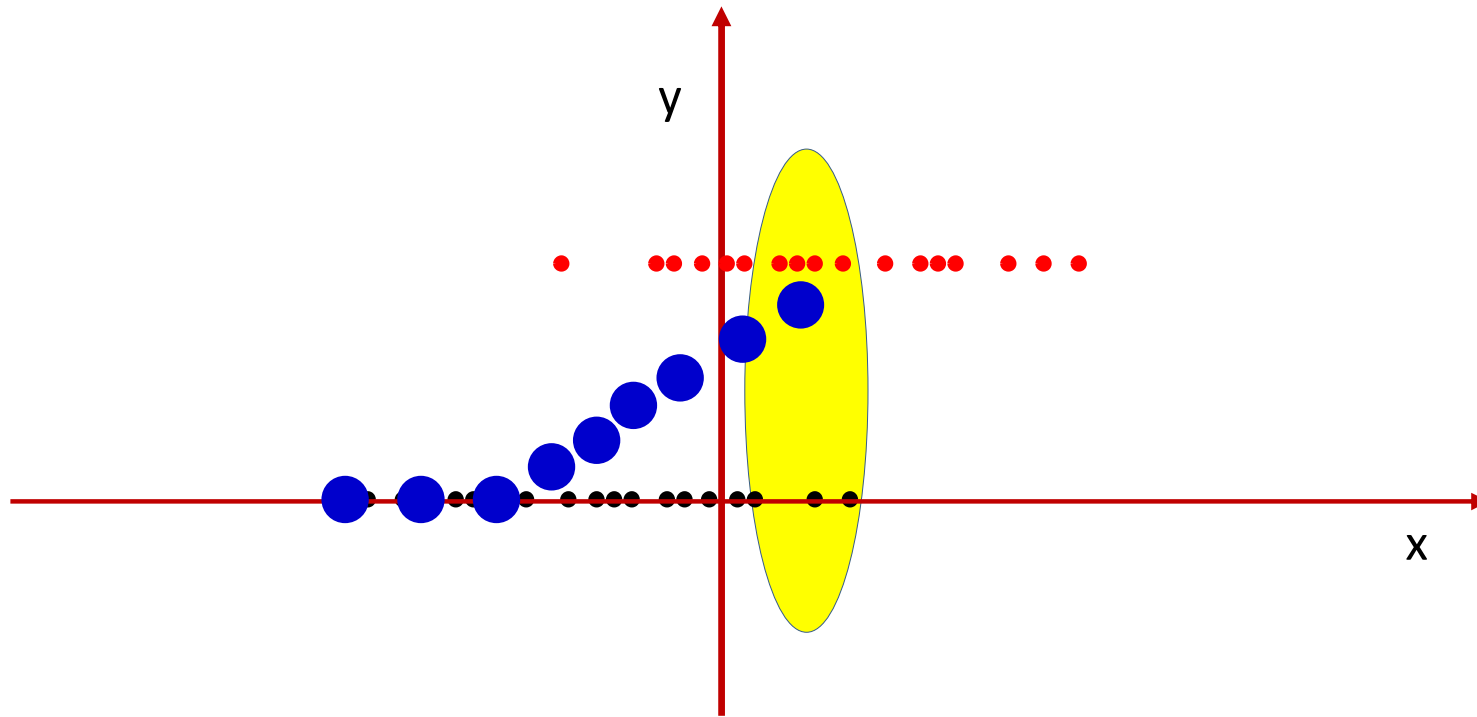

- Consider this differently: at each point look at a small window around that point
- Plot the average value within the window
 - This is an approximation of the *probability* of 1 at that point

The *probability* of $y=1$

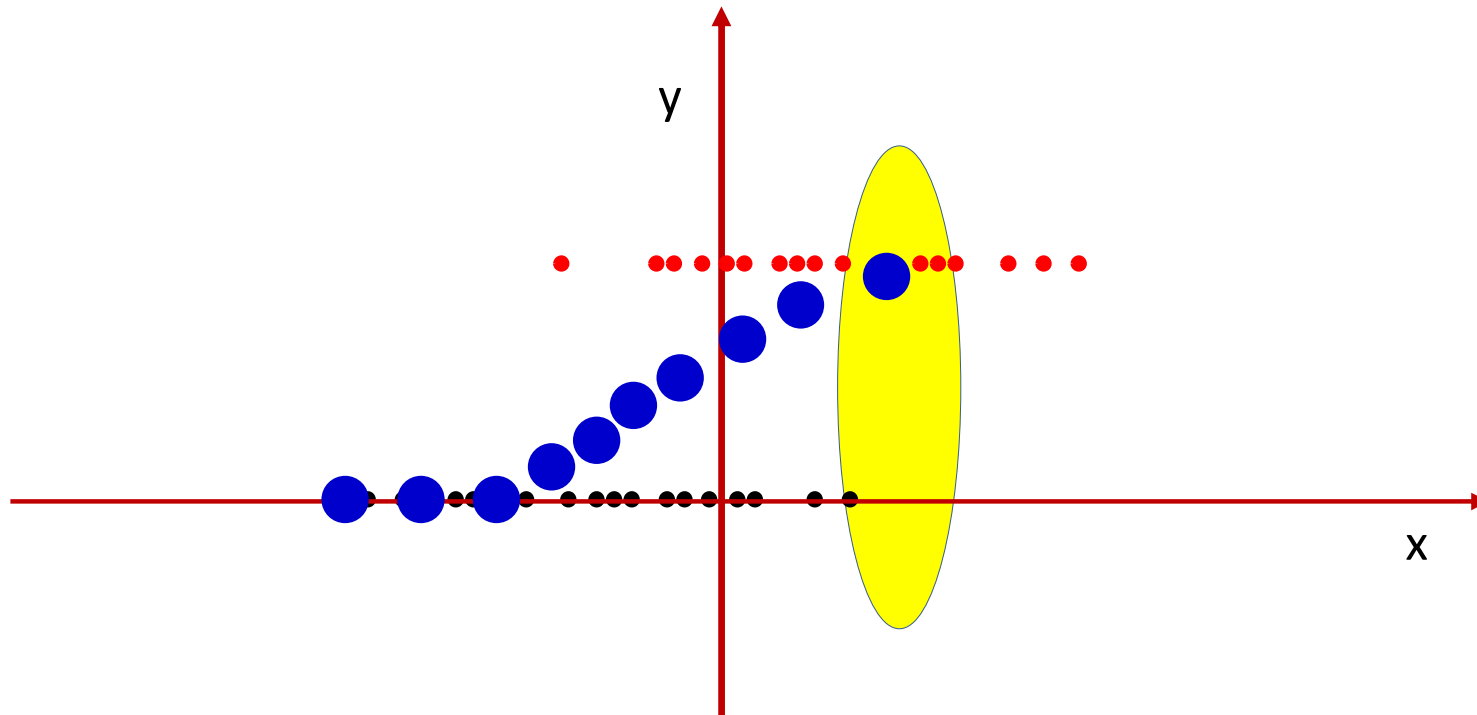

- Consider this differently: at each point look at a small window around that point
- Plot the average value within the window
 - This is an approximation of the *probability* of 1 at that point

The *probability* of $y=1$

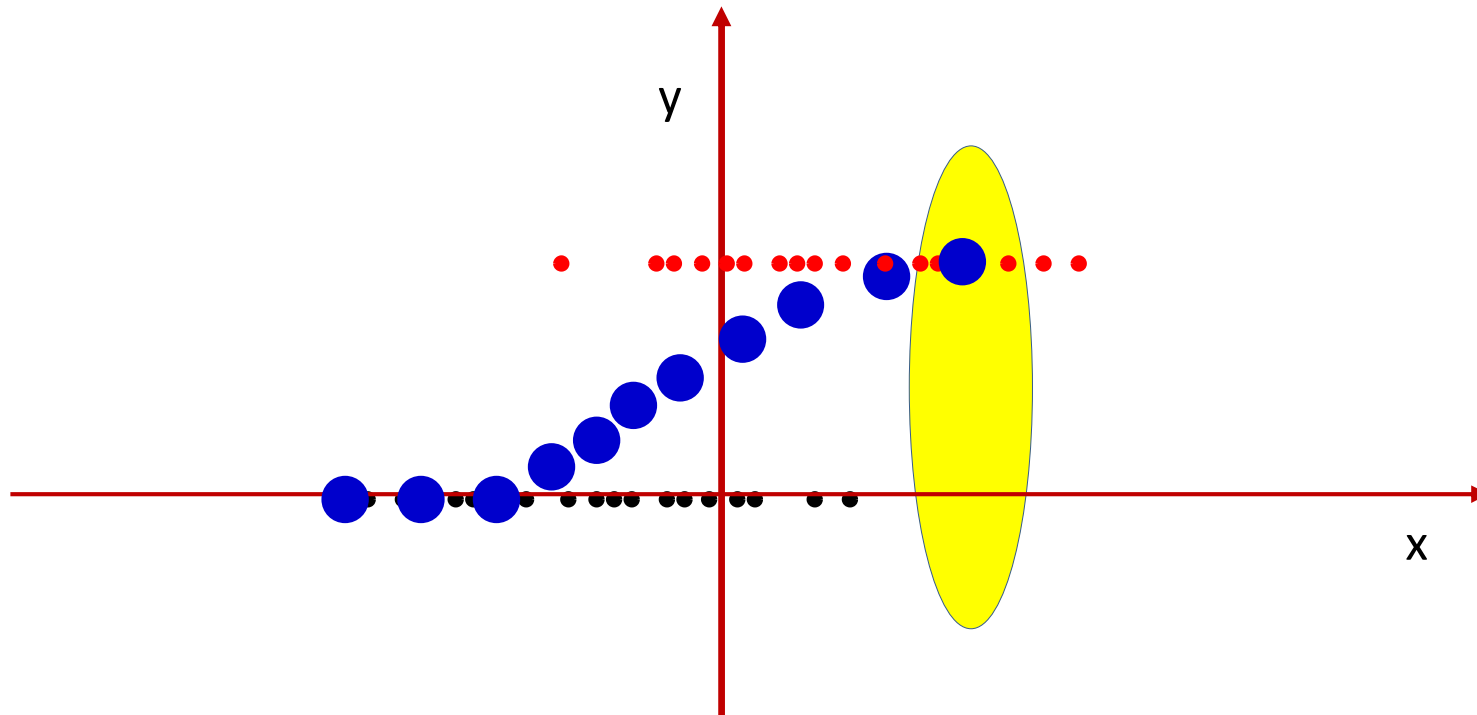

- Consider this differently: at each point look at a small window around that point
- Plot the average value within the window
 - This is an approximation of the *probability* of 1 at that point

The *probability* of $y=1$

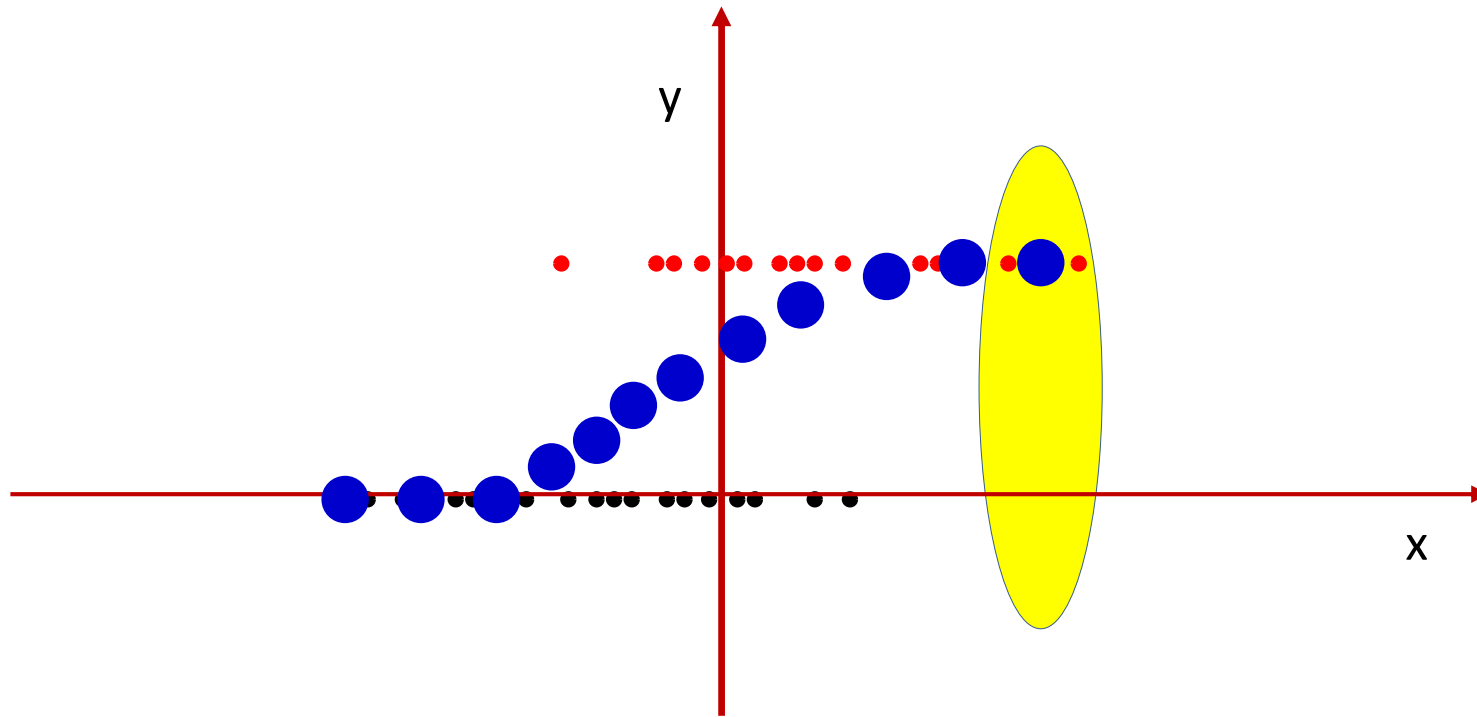

- Consider this differently: at each point look at a small window around that point
- Plot the average value within the window
 - This is an approximation of the *probability* of 1 at that point

The *probability* of $y=1$

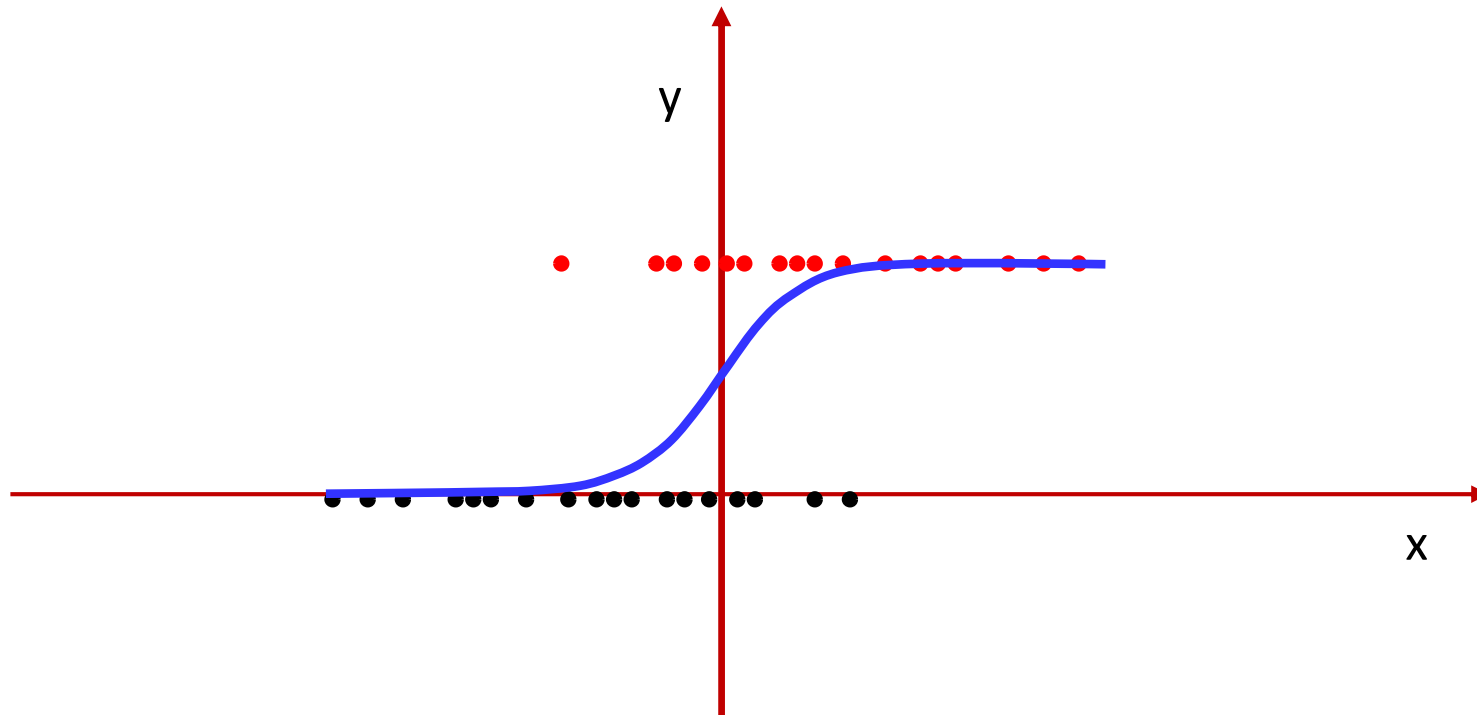

- Consider this differently: at each point look at a small window around that point
- Plot the average value within the window
 - This is an approximation of the *probability* of 1 at that point

The logistic regression model

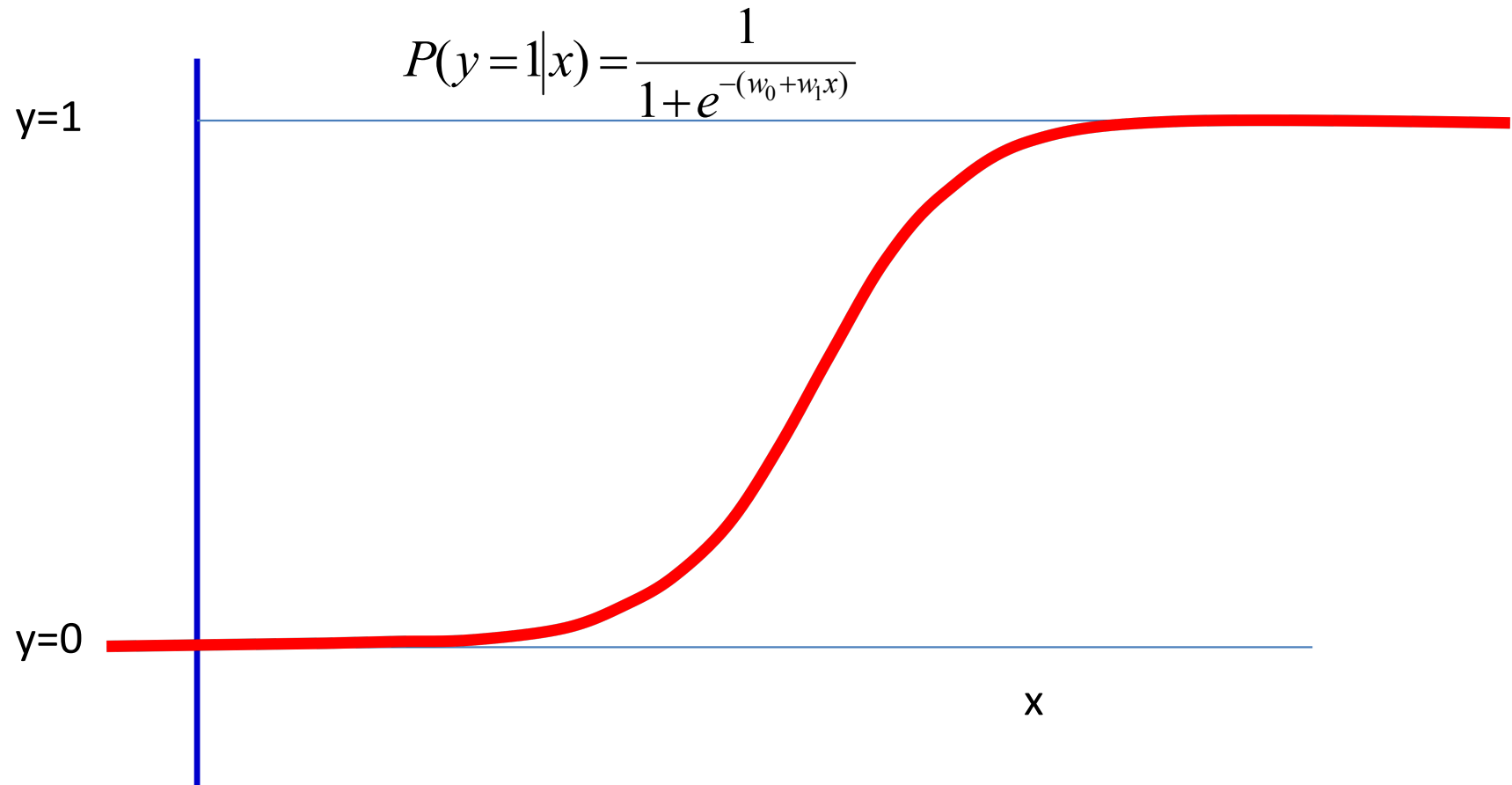

- Class 1 becomes increasingly probable going left to right
 - Very typical in many problems

The logistic perceptron

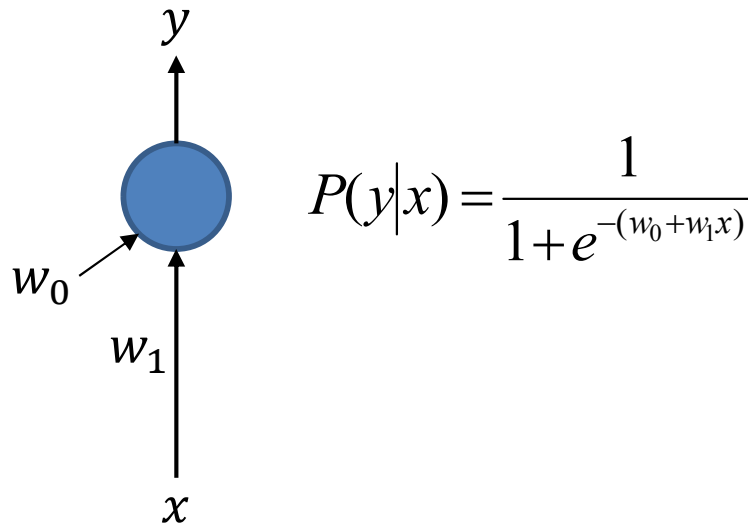

- A sigmoid perceptron with a single input models the *a posteriori* probability of the class given the input

Linearly inseparable data

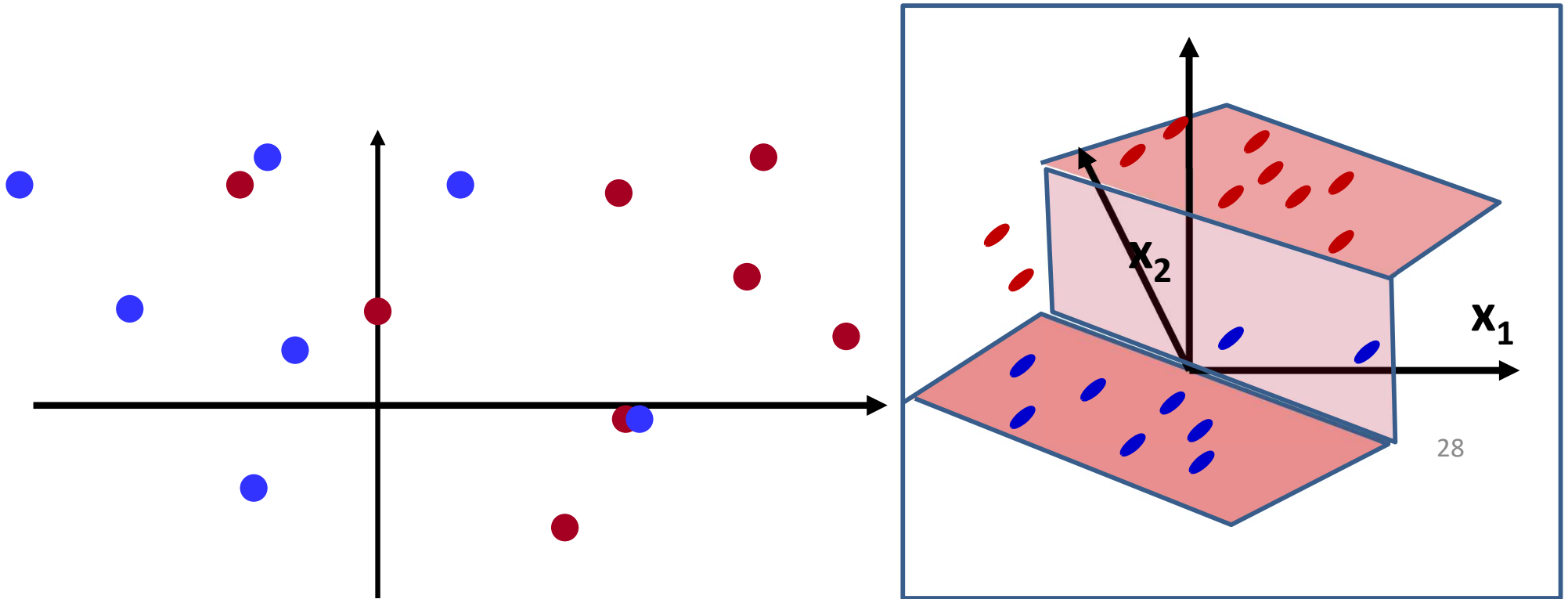

- Two-dimensional example
 - Blue dots (on the floor) on the “red” side
 - Red dots (suspended at $Y=1$) on the “blue” side
 - No line will cleanly separate the two colors

Logistic regression

$$P(Y = 1|X) = \frac{1}{1 + \exp(-(\sum_i w_i x_i + w_0))}$$

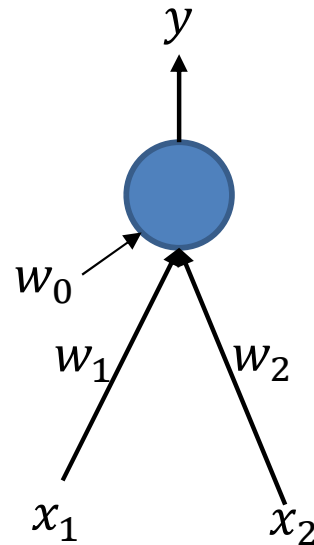
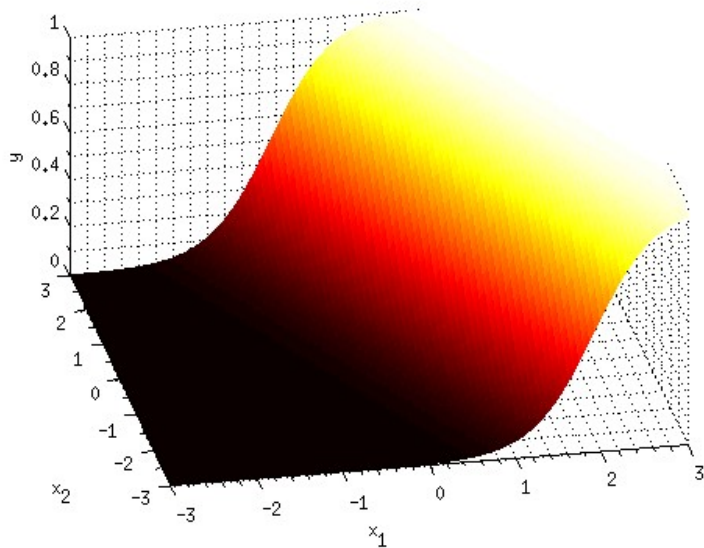

Decision: $y > 0.5$?

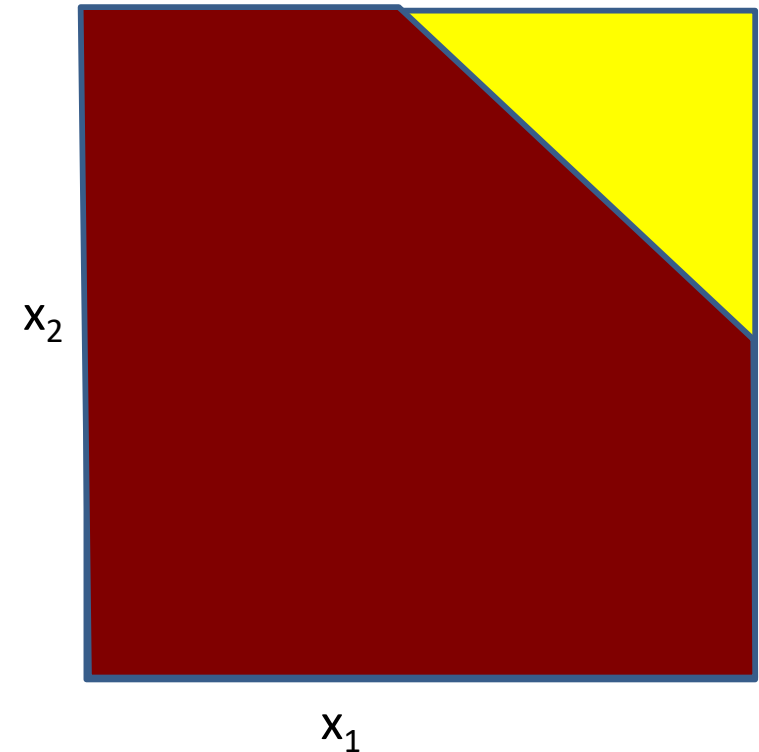

When X is a 2-D variable

- This is the perceptron with a sigmoid activation
 - It actually computes the *probability* that the input belongs to class 1
 - Decision boundaries may be obtained by comparing the probability to a threshold
 - These boundaries will be lines (hyperplanes in higher dimensions)
 - The sigmoid perceptron is a *linear classifier*

Estimating the model

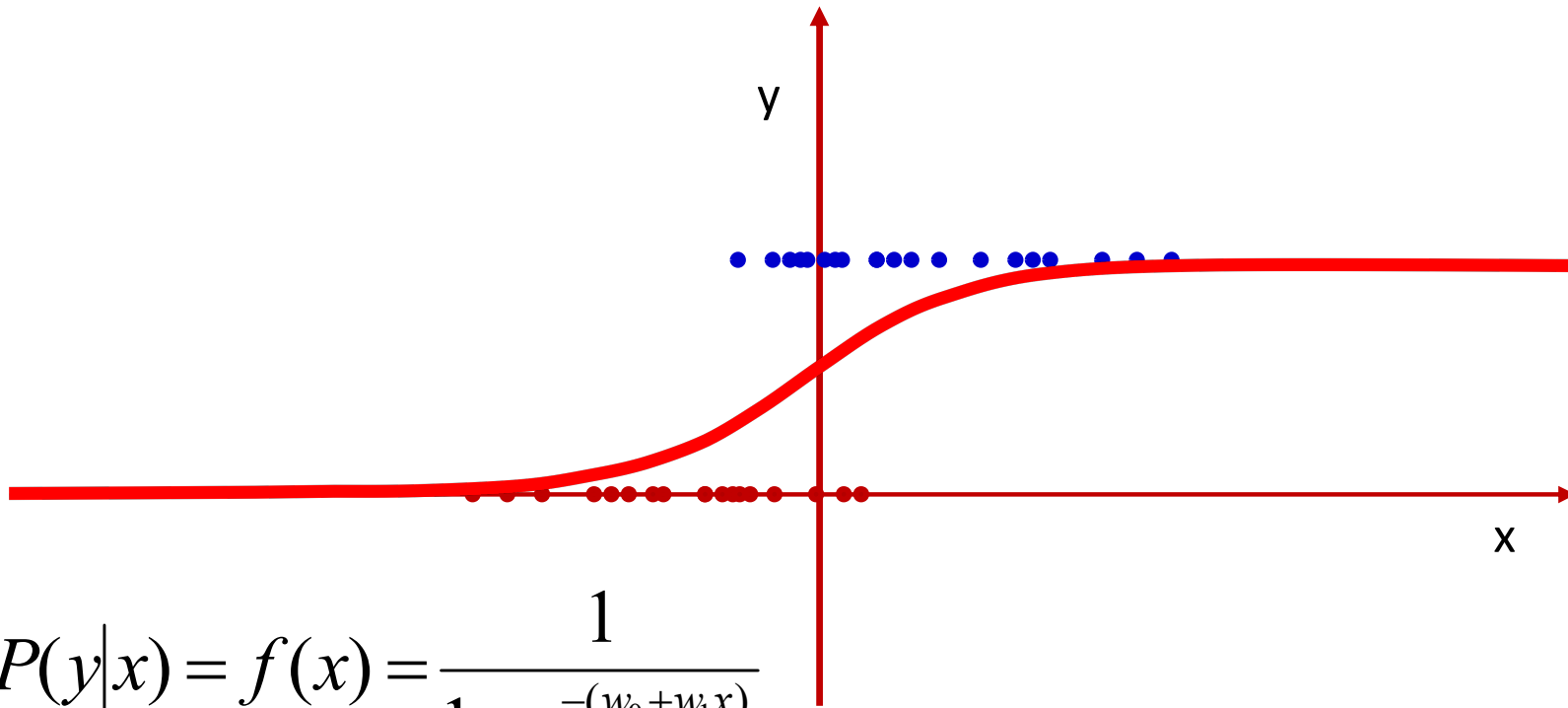

$$P(y|x) = f(x) = \frac{1}{1 + e^{-(w_0 + w_1 x)}}$$

- Given the training data (many (x, y) pairs represented by the dots), estimate w_0 and w_1 for the curve

Estimating the model

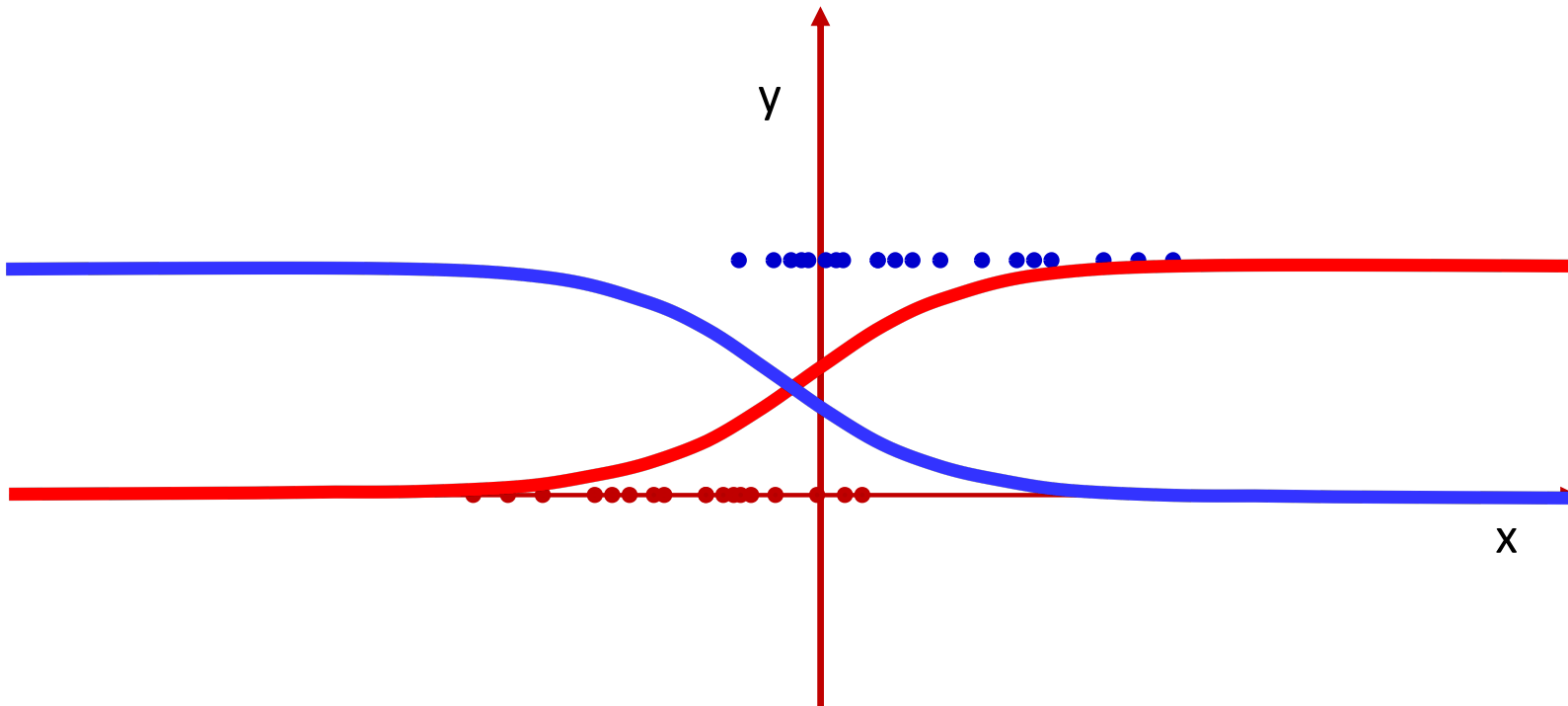

- Easier to represent using a $y = +1/-1$ notation

$$P(y = 1|x) = \frac{1}{1 + e^{-(w_0 + w_1 x)}}$$

$$P(y = -1|x) = \frac{1}{1 + e^{(w_0 + w_1 x)}}$$

$$P(y|x) = \frac{1}{1 + e^{-y(w_0 + w_1 x)}}$$

Estimating the model

- Given: Training data

$$(X_1, y_1), (X_2, y_2), \dots, (X_N, y_N)$$

- X s are vectors, y s are binary (1/-1) class values
- Total probability of data

$$\begin{aligned} P((X_1, y_1), (X_2, y_2), \dots, (X_N, y_N)) &= \prod_i P(X_i, y_i) \\ &= \prod_i P(X_i)P(y_i|X_i) = \prod_i P(X_i) \frac{1}{1 + e^{-y_i(w_0 + w^T X_i)}} \end{aligned}$$

Estimating the model

- Given: Training data

$$\begin{aligned} P(\text{Training data}) &= \prod_i P(X_i) \frac{1}{1 + e^{-y_i(w_0 + w^T X_i)}} \\ &= \prod_i P(X_i) \prod_i \frac{1}{1 + e^{-y_i(w_0 + w^T X_i)}} \end{aligned}$$

- $\log P(\text{Training data}) =$

$$\sum_i \log P(X_i) + \sum_i \log \left(\frac{1}{1 + e^{-y_i(w_0 + w^T X_i)}} \right)$$

Maximum likelihood estimation

- Log Likelihood

$$\log P(\text{Training data}) =$$

$$\sum_i \log P(X_i) + \sum_i \log \left(\frac{1}{1 + e^{-y_i(w_0 + w^T X_i)}} \right)$$

- Maximum likelihood estimation

$$\hat{w}_0, \hat{w}_1 = \operatorname{argmax}_{w_0, w_1} \log P(\text{Training data})$$

- Focusing on the bits that invoke the parameters

$$\hat{w}_0, \hat{w}_1 = \operatorname{argmax}_{w_0, w_1} \sum_i \log \left(\frac{1}{1 + e^{-y_i(w_0 + w^T X_i)}} \right)$$

$$\hat{w}_0, \hat{w}_1 = \operatorname{argmin}_{w_0, w_1} \left(- \sum_i \log \left(\frac{1}{1 + e^{-y_i(w_0 + w^T X_i)}} \right) \right)$$

Maximum Likelihood Estimate

- Equals (note argmin rather than argmax)

$$\hat{w}_0, \hat{w}_1 = \operatorname{argmin}_{w_0, w_1} \left(- \sum_i \log \left(\frac{1}{1 + e^{-y_i(w_0 + w^T X_i)}} \right) \right)$$

- Identical to minimizing the KL divergence between the desired output y and actual output $\frac{1}{1 + e^{-(w_0 + w^T X_i)}}$
- Maximum likelihood learning of a logistic minimizes the KL divergence between its output and the target output
- Cannot be solved directly, needs gradient descent

So what about this one?

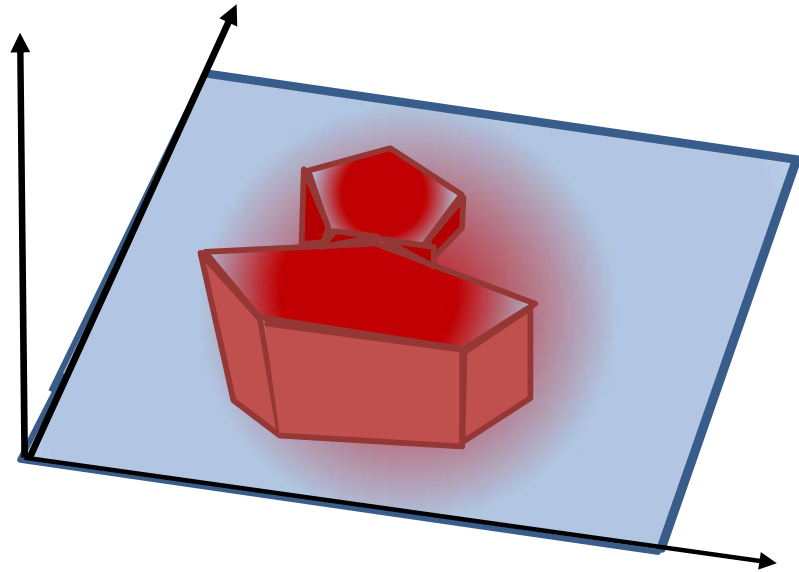
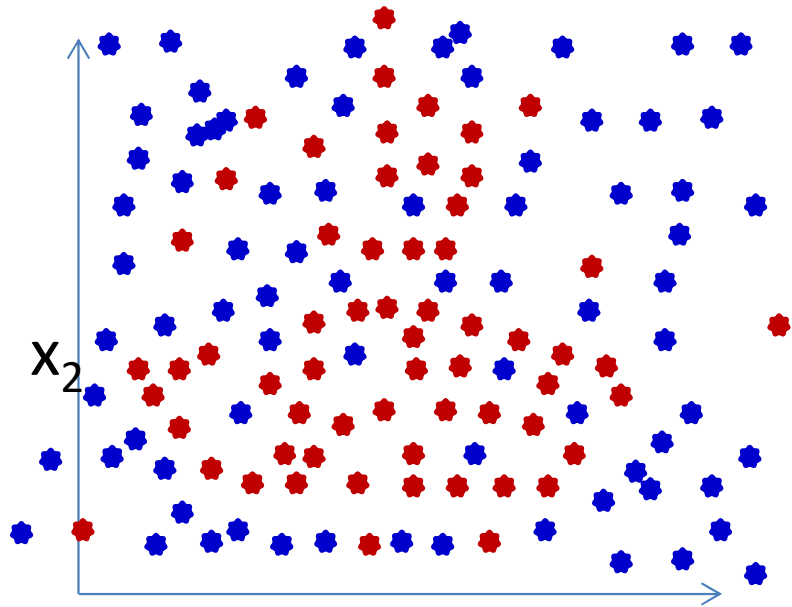

- Non-linear classifiers..

First consider the separable case..

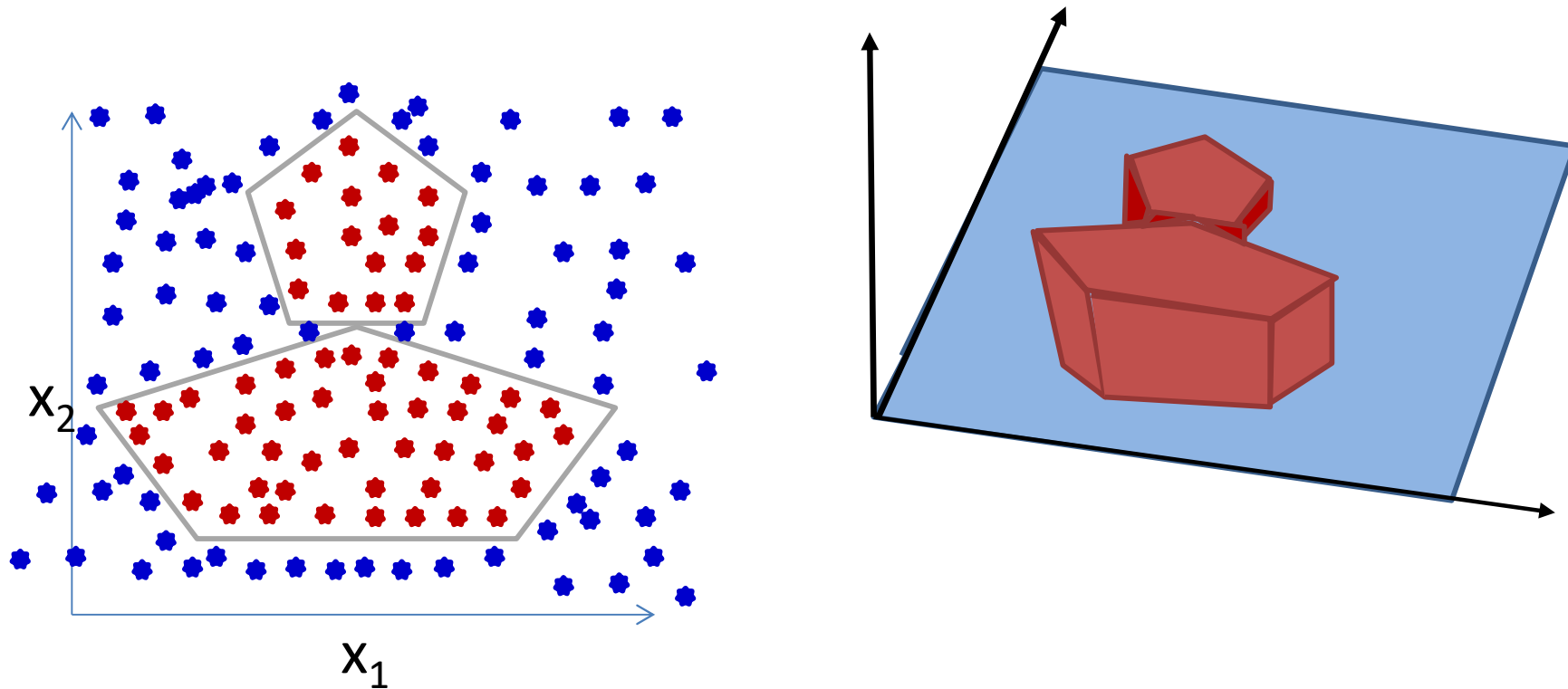

- When the net must learn to classify..

First consider the separable case..

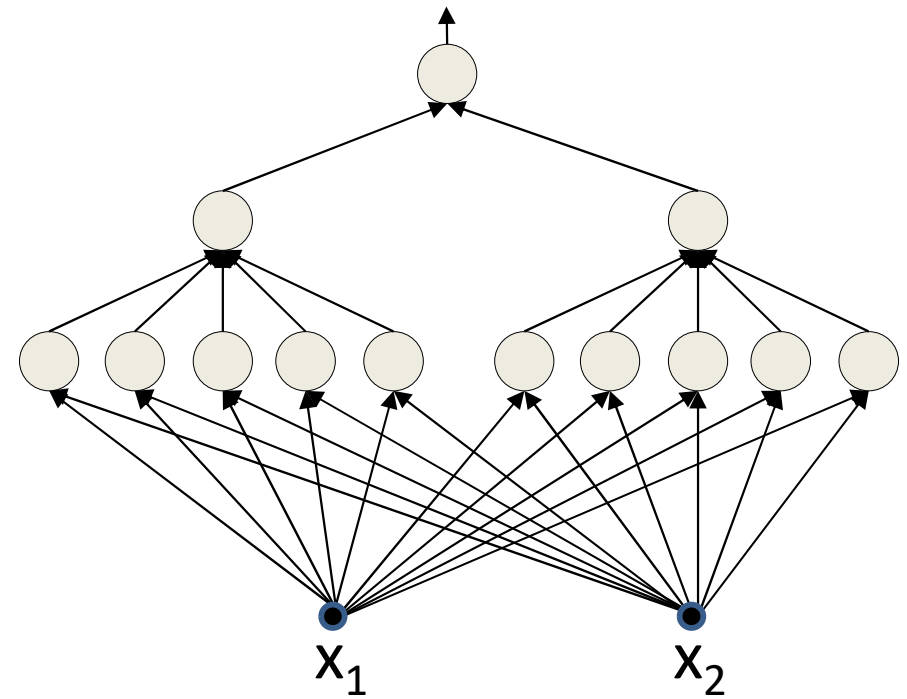
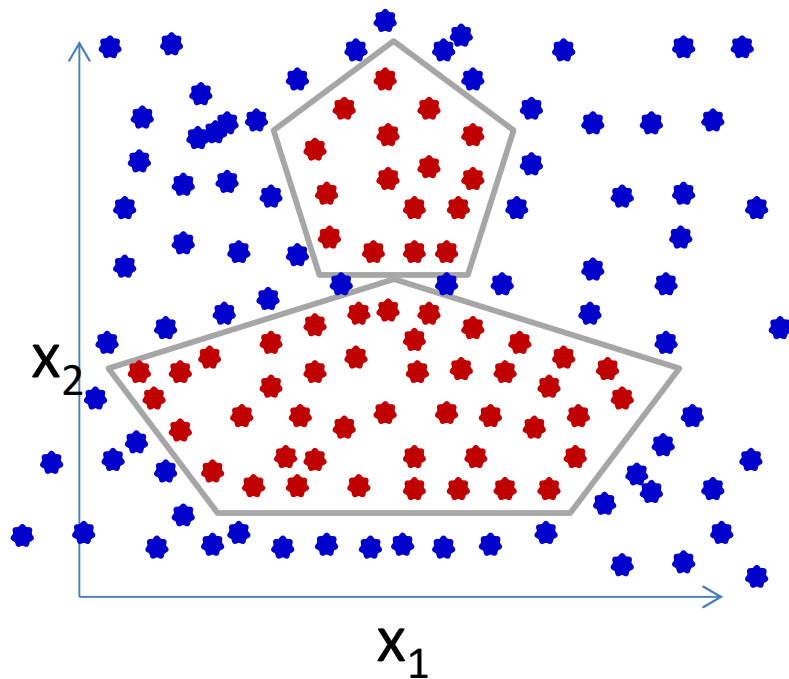

- For a “sufficient” net

First consider the separable case..

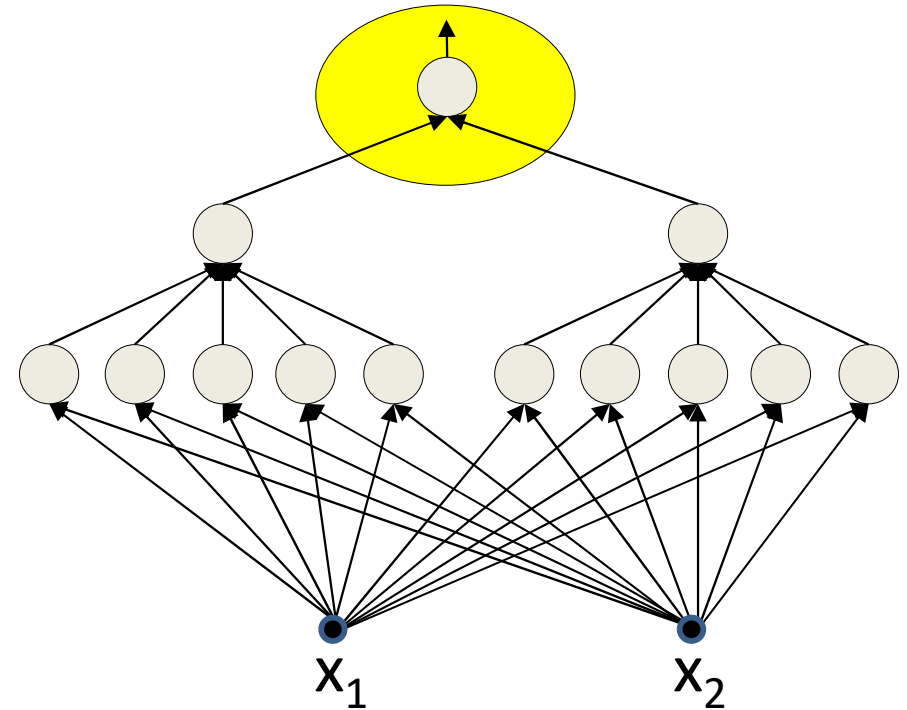
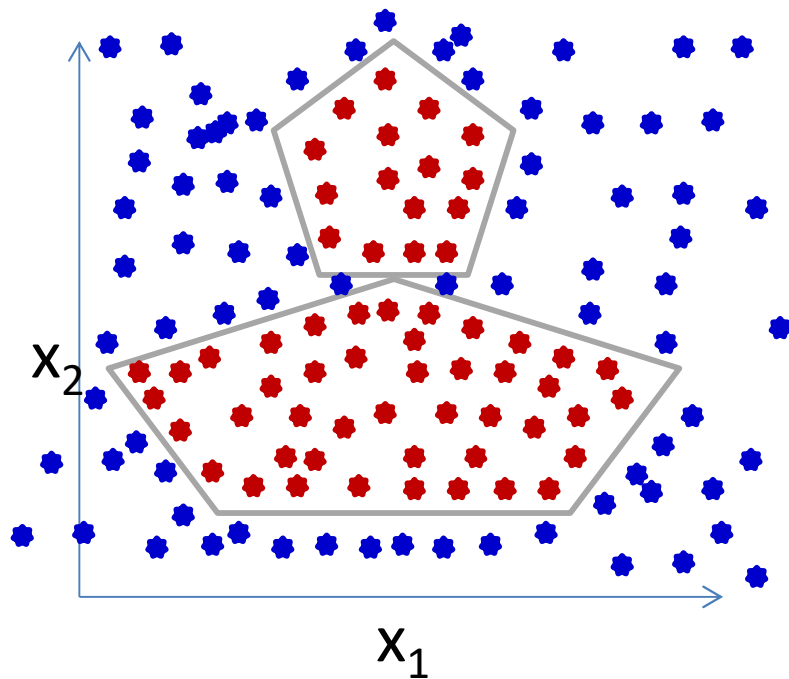

- For a “sufficient” net
- This final perceptron is a linear classifier

First consider the separable case..

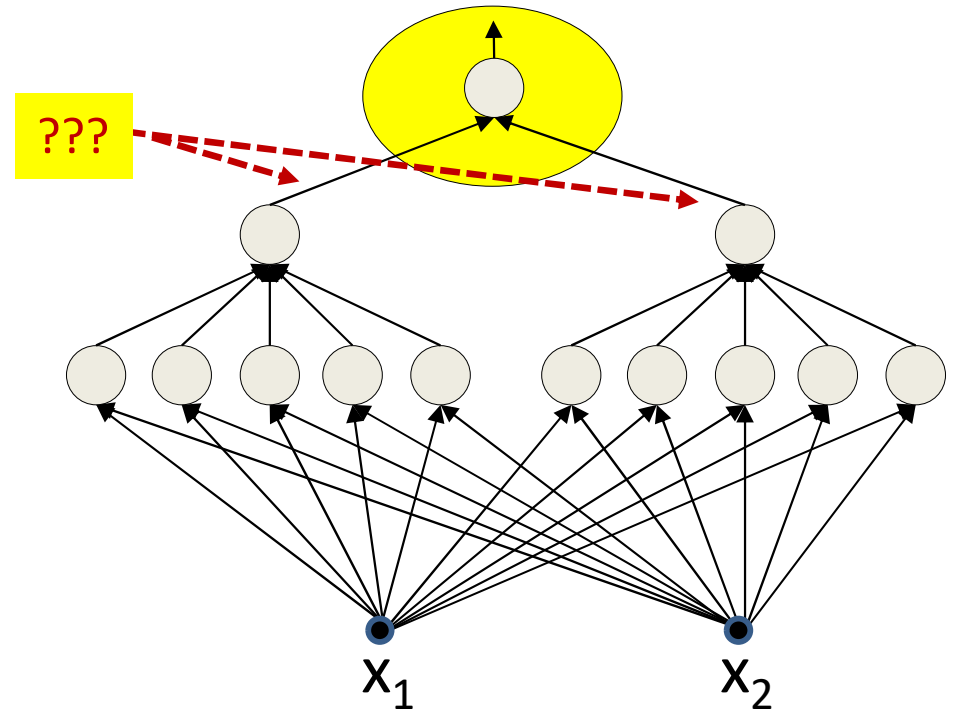
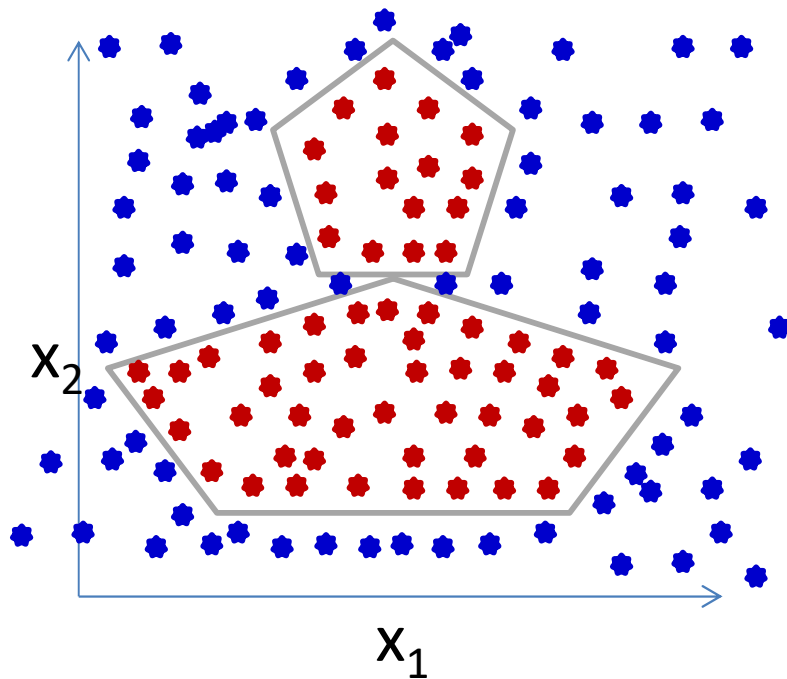

- For a “sufficient” net
- This final perceptron is a linear classifier over the output of the penultimate layer

First consider the separable case..

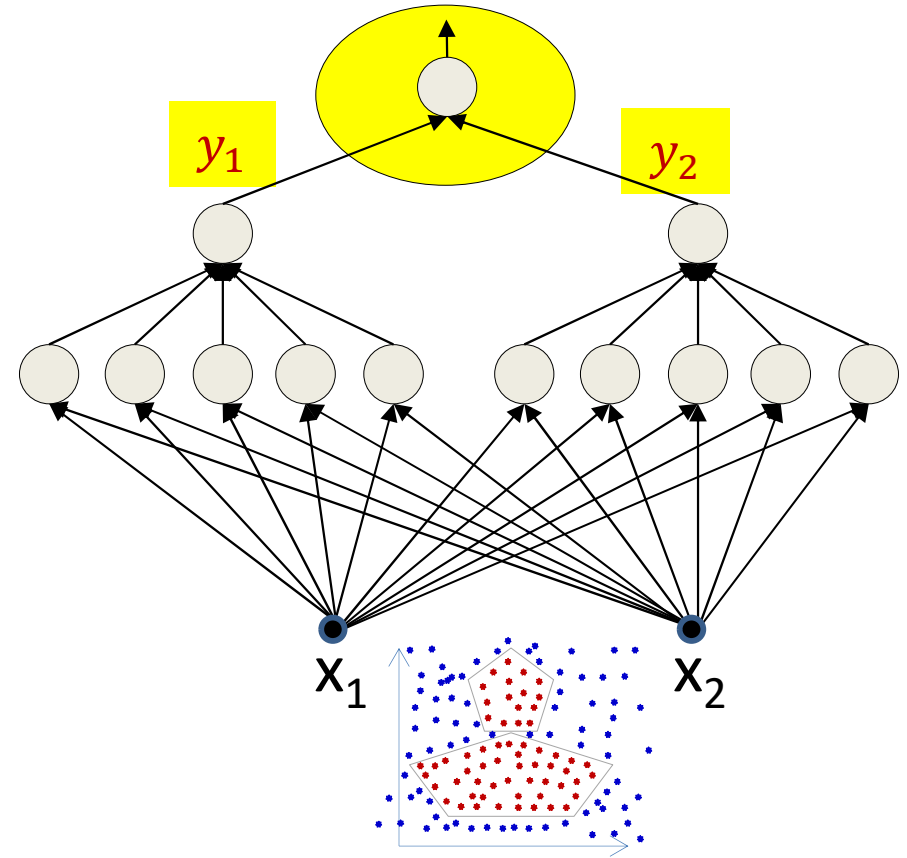
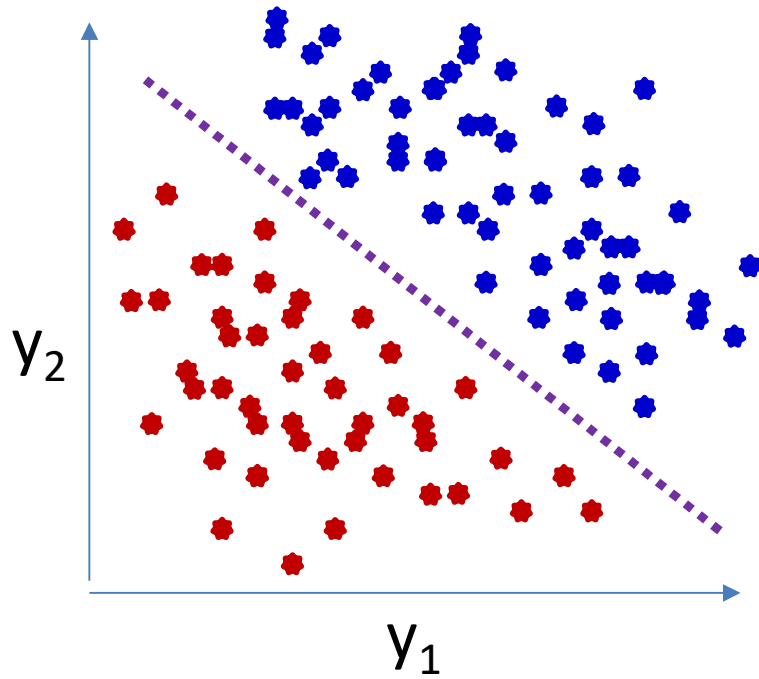

- For perfect classification the output of the penultimate layer must be linearly separable

First consider the separable case..

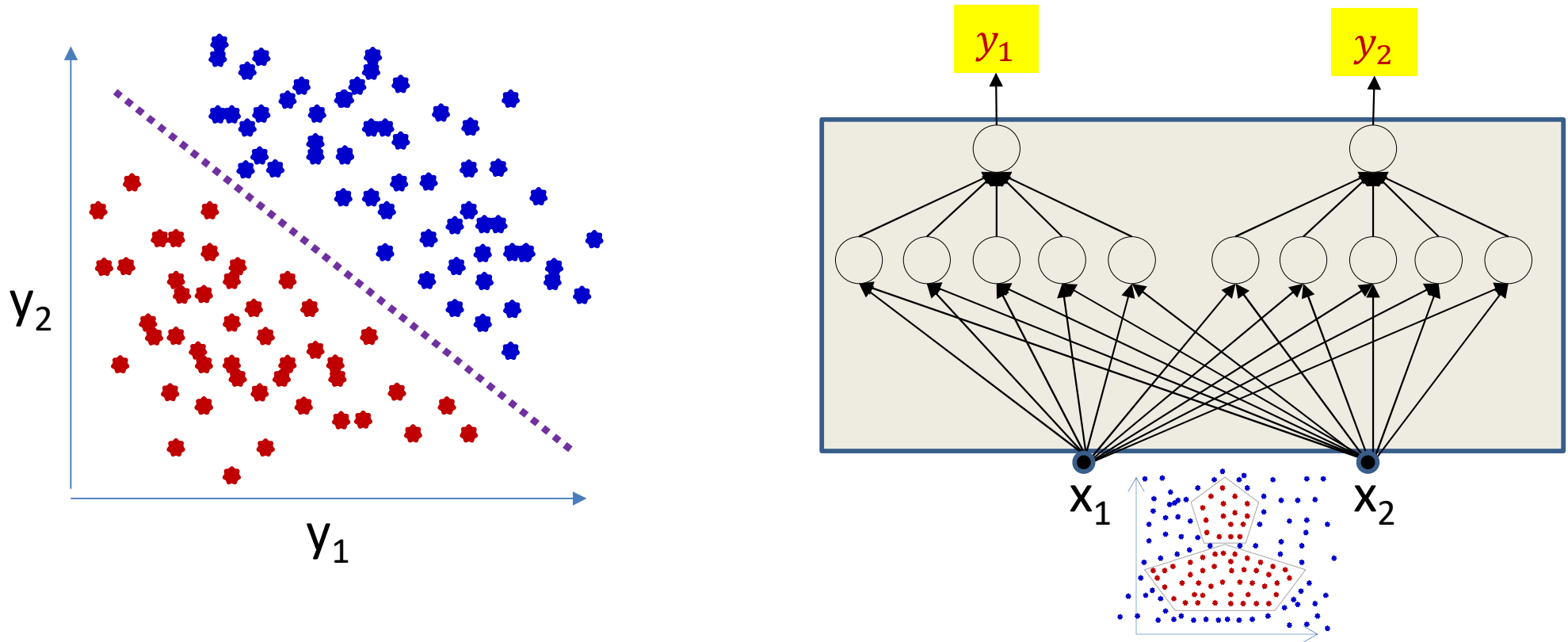

- For perfect classification the output of the penultimate layer must be linearly separable
- The rest of the network may be viewed as a transformation that transforms data from non-linear classes to linearly separable features

First consider the separable case..

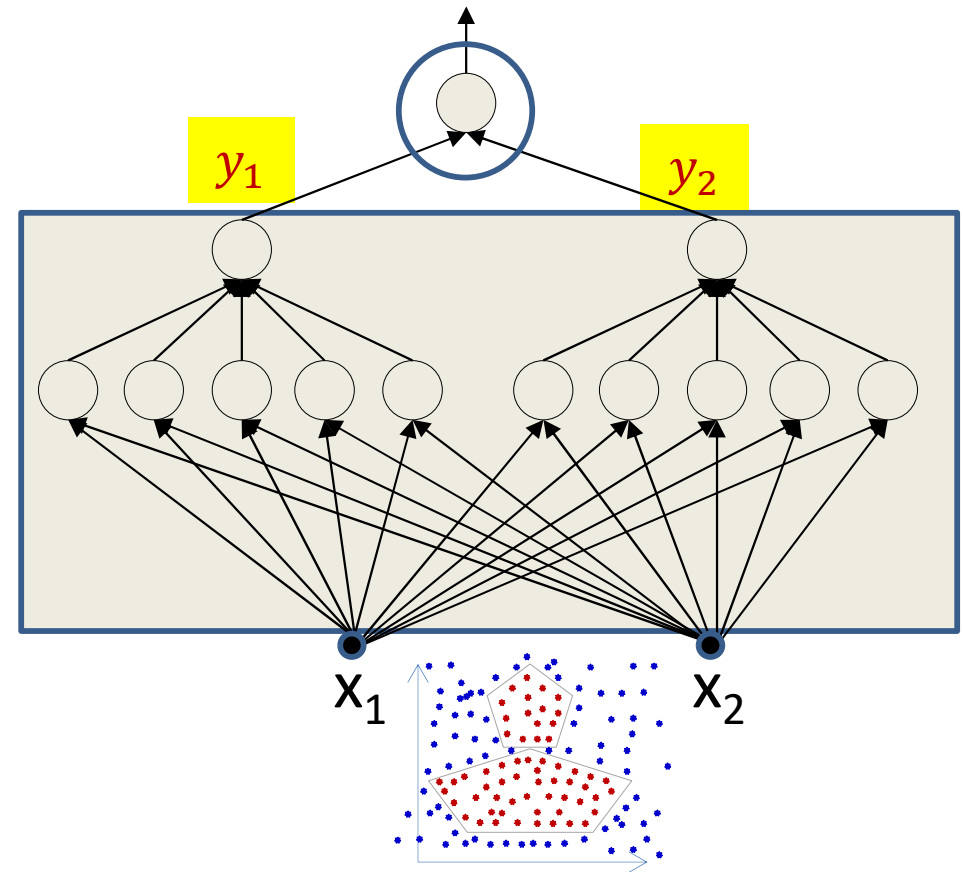
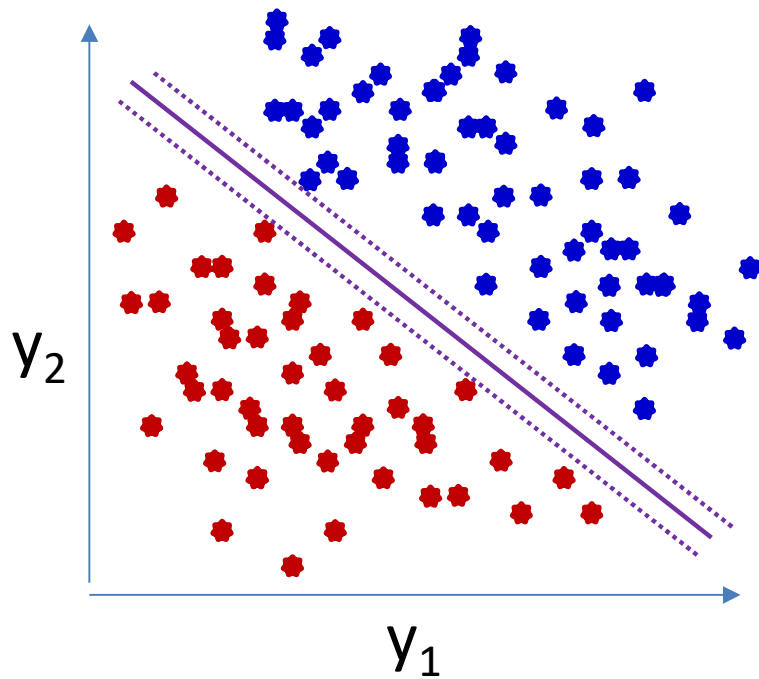

- The rest of the network may be viewed as a transformation that transforms data from non-linear classes to linearly separable features
 - We can now attach *any* linear classifier above it for perfect classification
 - Need not be a perceptron
 - In fact, for **binary** classifiers an SVM on top of the features may be more generalizable!

First consider the separable case..

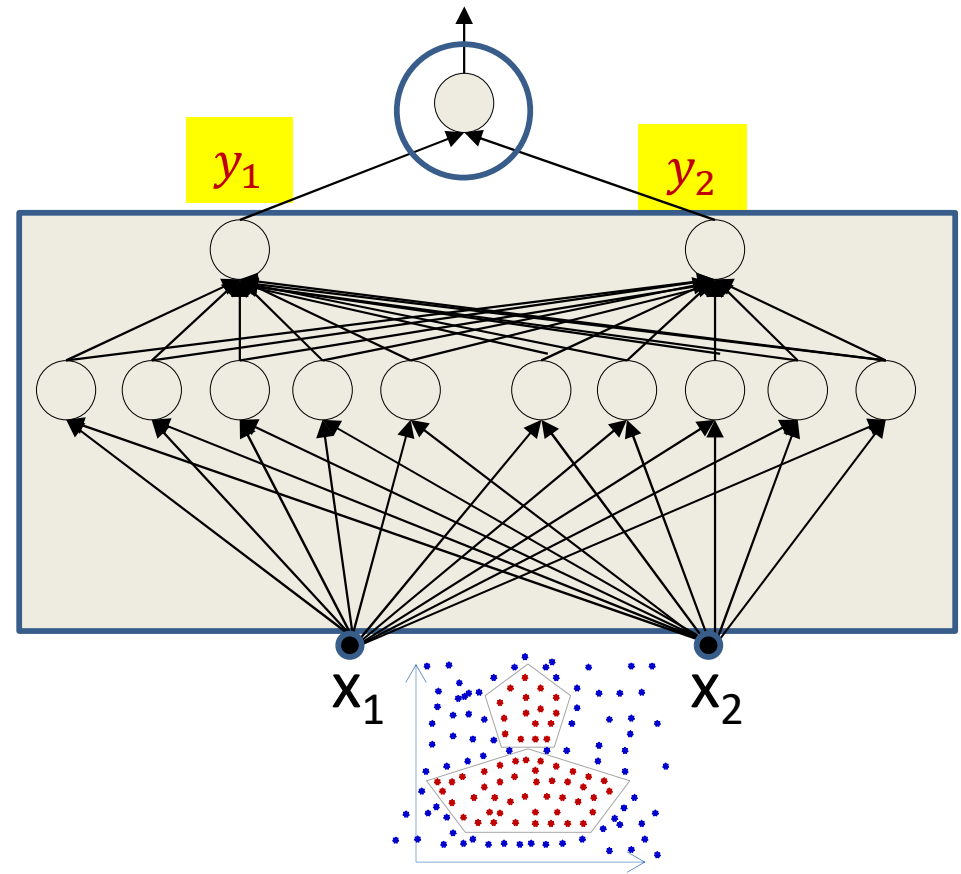
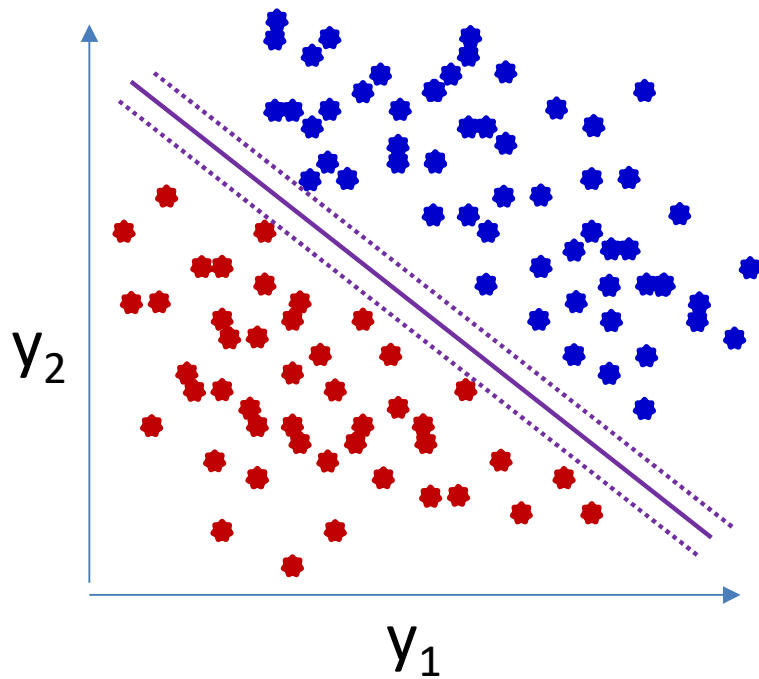

- This is true of *any* sufficient structure
 - Not just the optimal one
- For *insufficient* structures, the network may *attempt* to transform the inputs to linearly separable features
 - Will fail to separate

Poll 1 (@1055, @1056)

The portion of a network until the second-to-last layer (i.e. the layer just before the output layer) is essentially a “feature extraction” module that extracts linearly separable features for the classes, true or false?

- True
- False

The output layer is a linear classifier that can only perform well if the rest of network transforms the input space such that the classes are linearly separable, true or false

- True
- False

Poll 1

The portion of a network until the second-to-last layer (i.e. the layer just before the output layer) is essentially a “feature extraction” module that extracts linearly separable features for the classes, true or false?

- True
- False

The output layer is a linear classifier that can only perform well if the rest of network transforms the input space such that the classes are linearly separable, true or false

- True
- False

Mathematically..

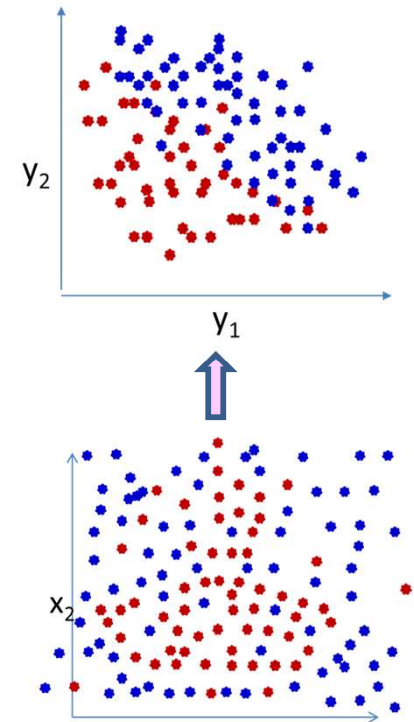
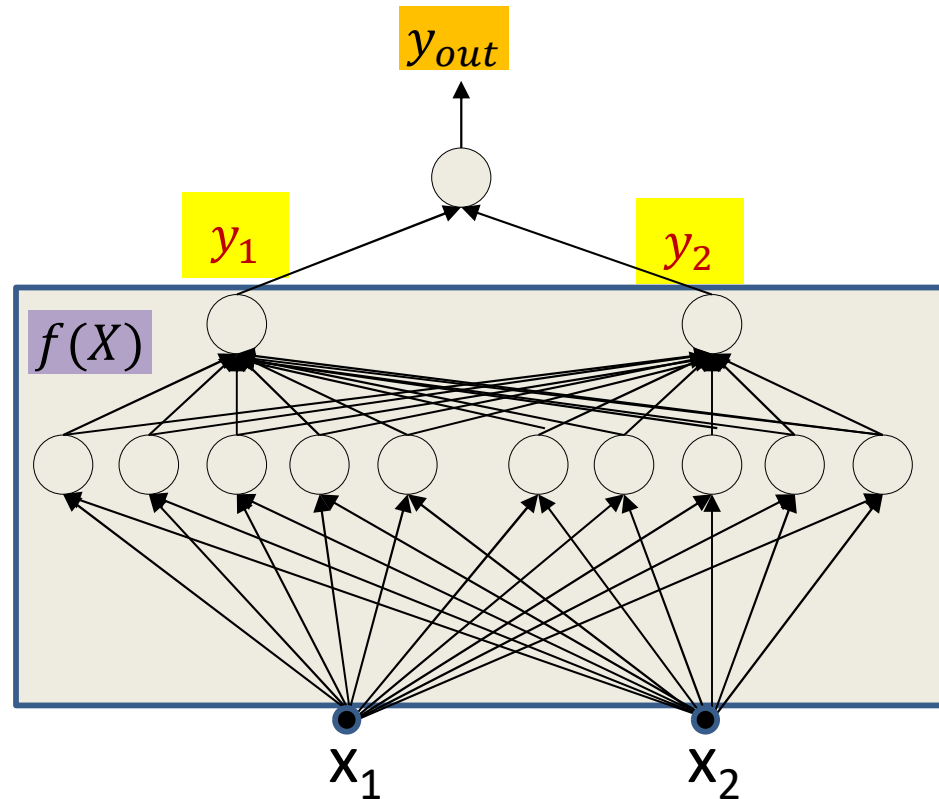

$$y_{out} = \frac{1}{1 + \exp(b + W^T Y)} = \frac{1}{1 + \exp(b + W^T f(X))}$$

- The data are (almost) linearly separable in the space of Y
- The network until the second-to-last layer is a non-linear function $f(X)$ that converts the input space of X into the feature space Y where the classes are maximally linearly separable

When the data are not separable and boundaries are not linear..

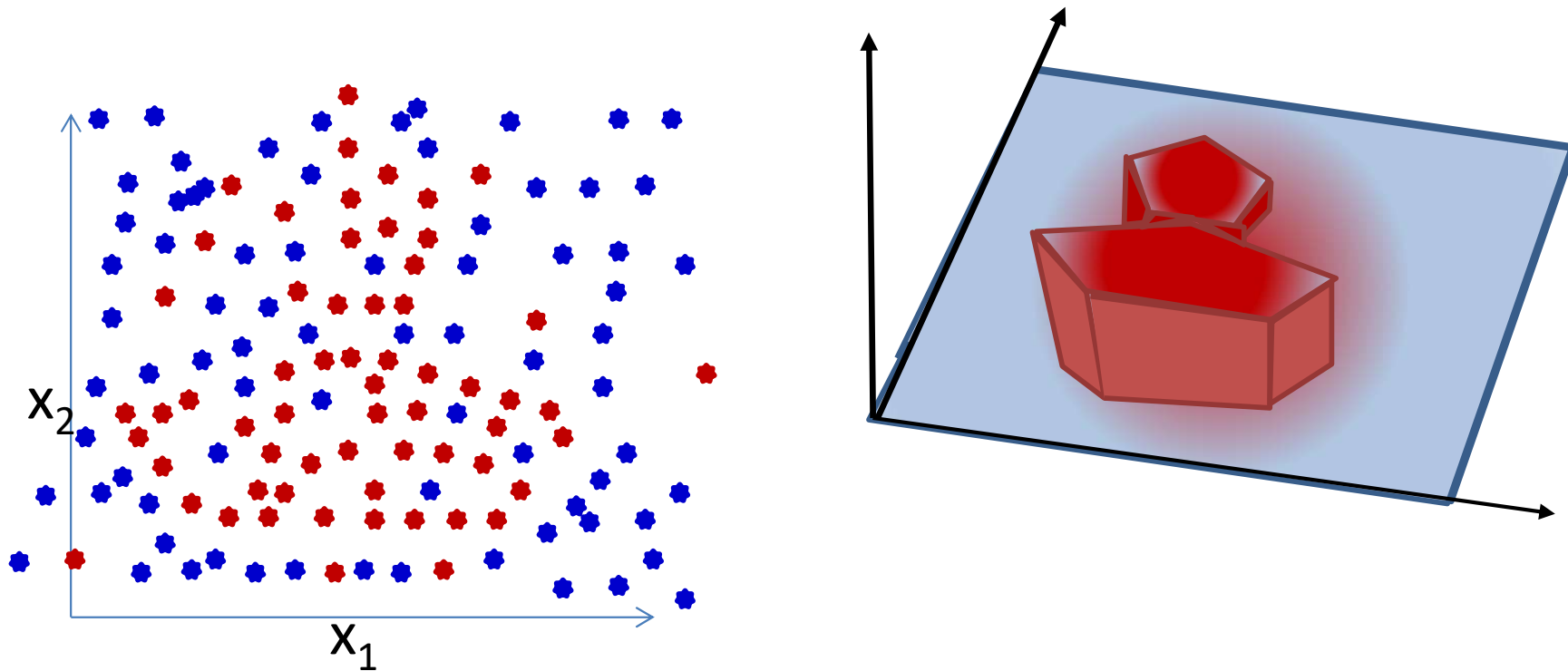

- More typical setting for classification problems

Inseparable classes with an output logistic perceptron

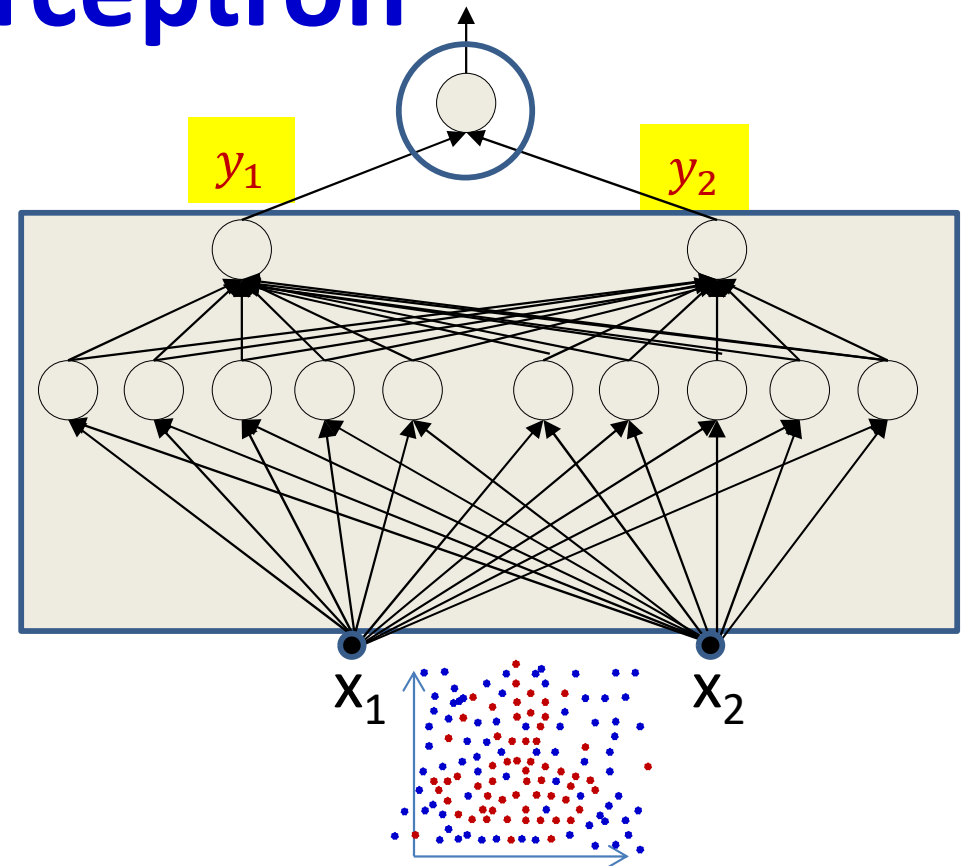
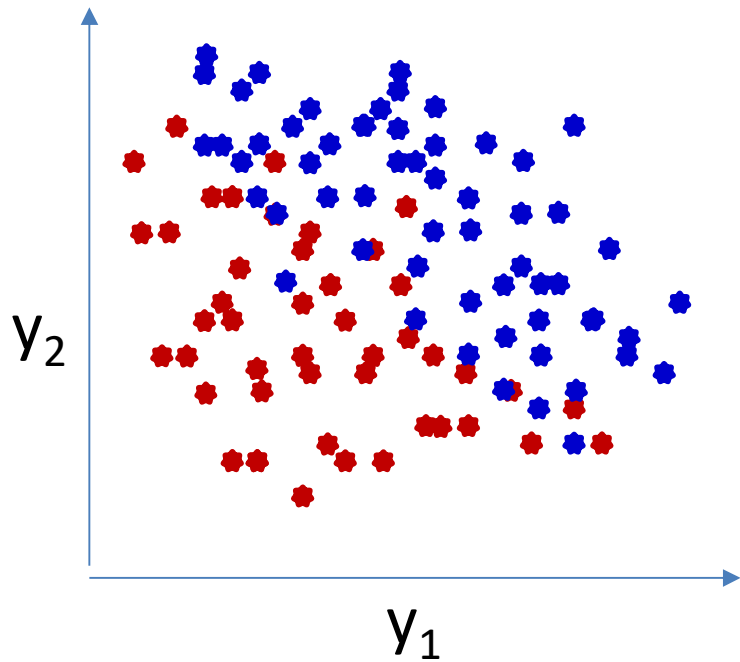

- The “feature extraction” layer transforms the data such that the posterior probability may now be modelled by a logistic

Inseparable classes with an output logistic perceptron

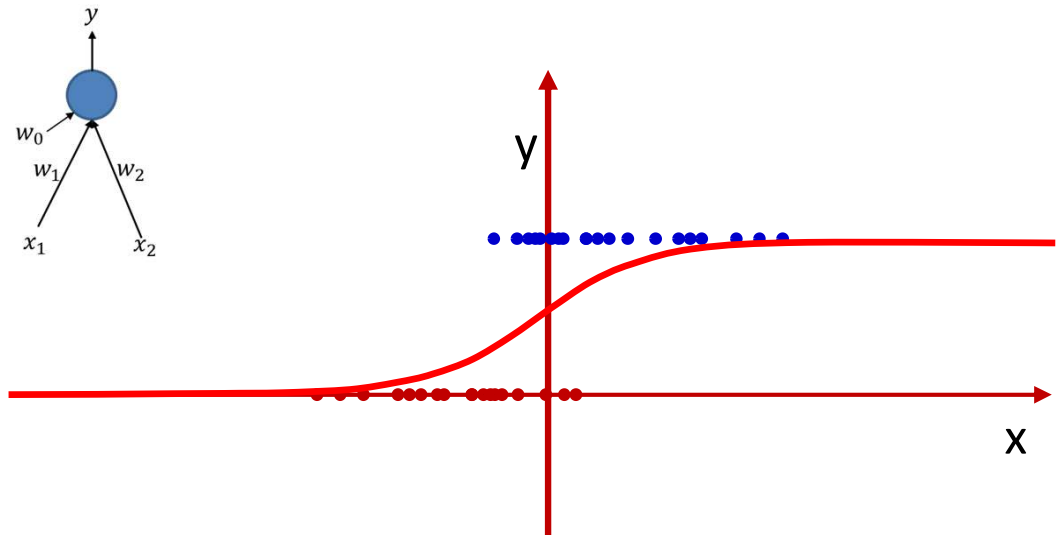
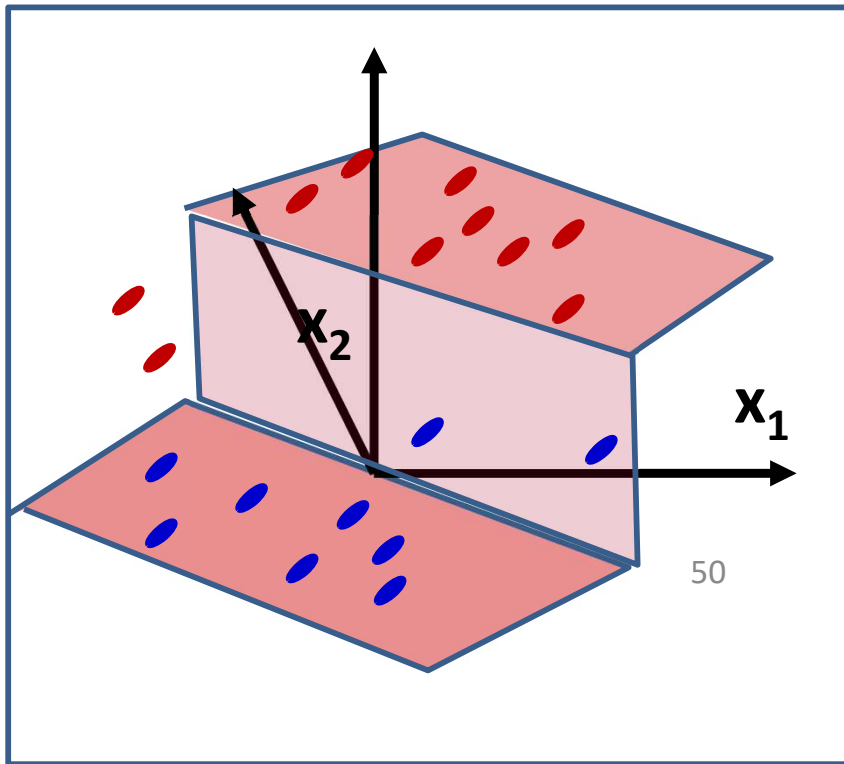

$$P(y|f(x)) = P(y|x) = \frac{1}{1 + e^{-(w_0 + w^T f(x))}}$$

- The output logistic computes the posterior probability of the class from the output of the feature extraction layer
 - This is the posterior probability of the class given $f(x)$
 - Which is the posterior probability of the class given x

When the data are not separable and boundaries are not linear..

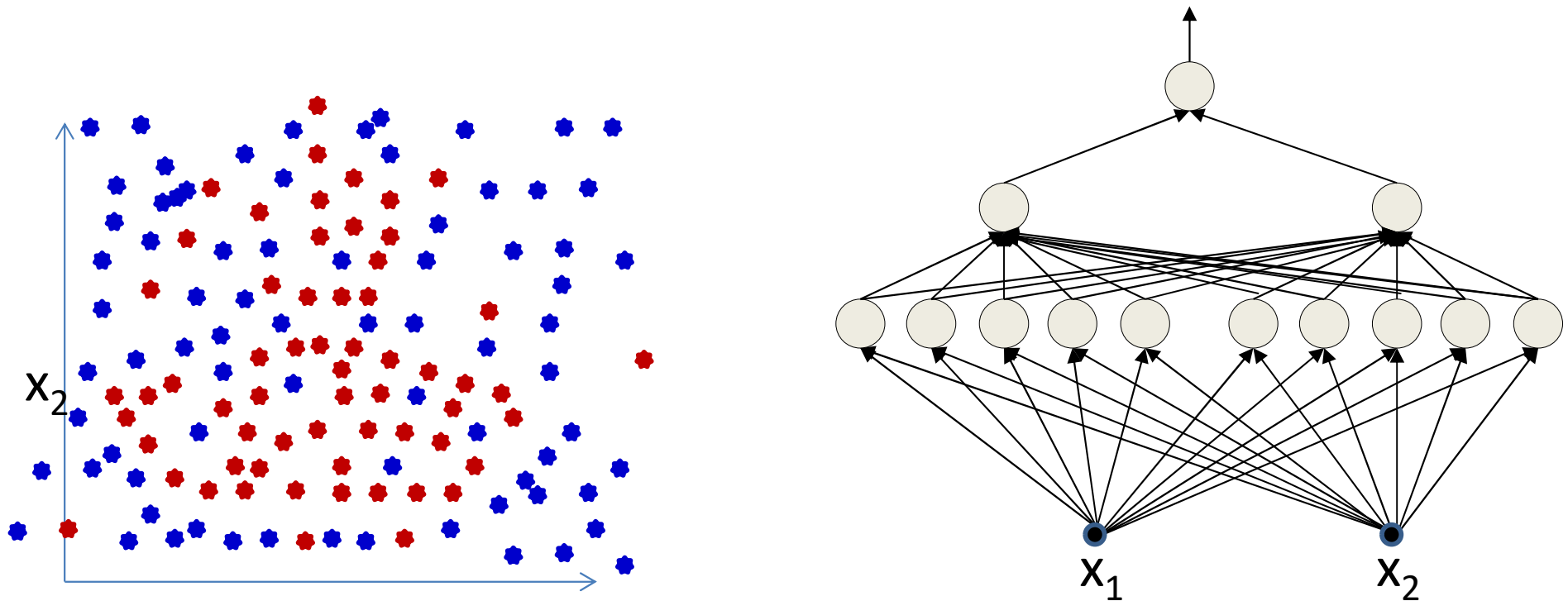

- The output of the network is $P(y|x)$
 - For multi-class networks, it will be the *vector* of a posteriori class probabilities
- If trained to minimize the KL divergence, the parameters of both, the final logistic/softmax and the network are learned to maximize $P(y|x)$
 - We actually perform *maximum likelihood* training of the network, which is just a statistical estimator

Poll 2 (@1057)

Select all that are true

- A (classification) neural network is just a statistical model that computes the a posteriori probabilities of the classes given the inputs
- Training the network to minimize the KL divergence (Xentropy loss) is the same as maximum likelihood training of the network
- Training the network by minimizing KL divergence gives us a maximum likelihood estimate of the network parameters only when the classes are separable
- It is valid, and possibly beneficial, to train the network, and subsequently replace the final (output) layer by any other linear classifier

Poll 2

Select all that are true

- **A (classification) neural network is just a statistical model that computes the a posteriori probabilities of the classes given the inputs**
- **Training the network to minimize the KL divergence (Xentropy loss) is the same as maximum likelihood training of the network**
- Training the network by minimizing KL divergence gives us a maximum likelihood estimate of the network parameters only when the classes are separable
- **It is valid, and possibly beneficial, to train the network, and subsequently replace the final (output) layer by any other linear classifier**

Story so far

- A classification MLP actually comprises two components
 - A “feature extraction network” that converts the inputs into linearly separable features
 - Or *nearly* linearly separable features
 - A final linear classifier that operates on the linearly separable features
- Using a softmax, the final layer of the network actually computes a posteriori probabilities of classes
 - Training the network to minimize KL divergence is identical to maximum-likelihood training of the network

How about the lower layers?

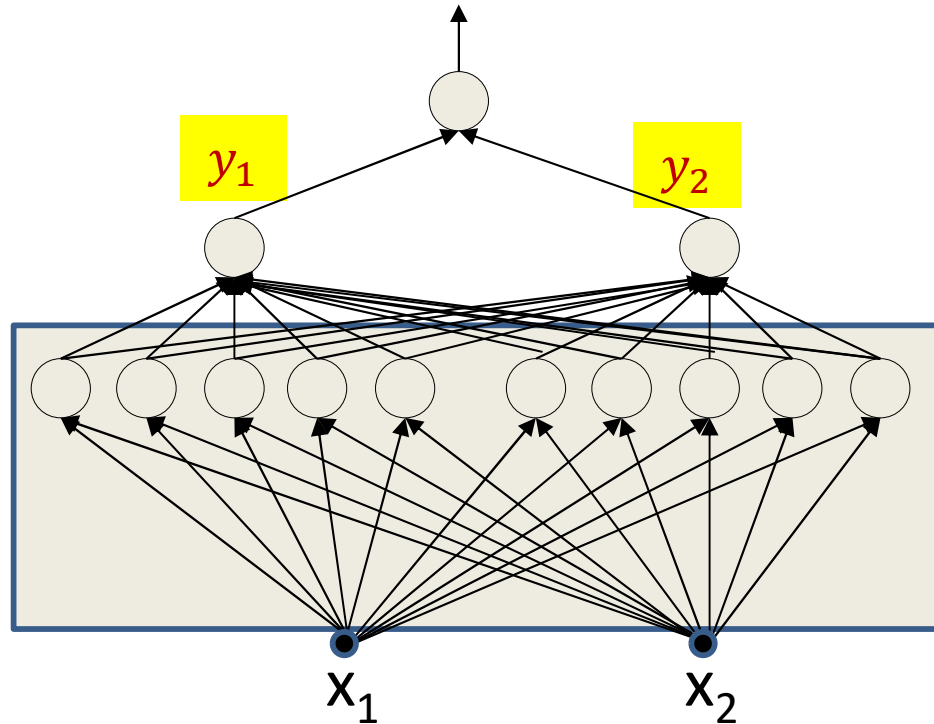

- How do the lower layers respond?
 - They too compute features
 - But how do they look
- Manifold hypothesis: For separable classes, the classes are linearly separable on a non-linear manifold
- Layers sequentially “straighten” the data manifold
 - Until the final layer, which fully linearizes it

The behavior of the layers

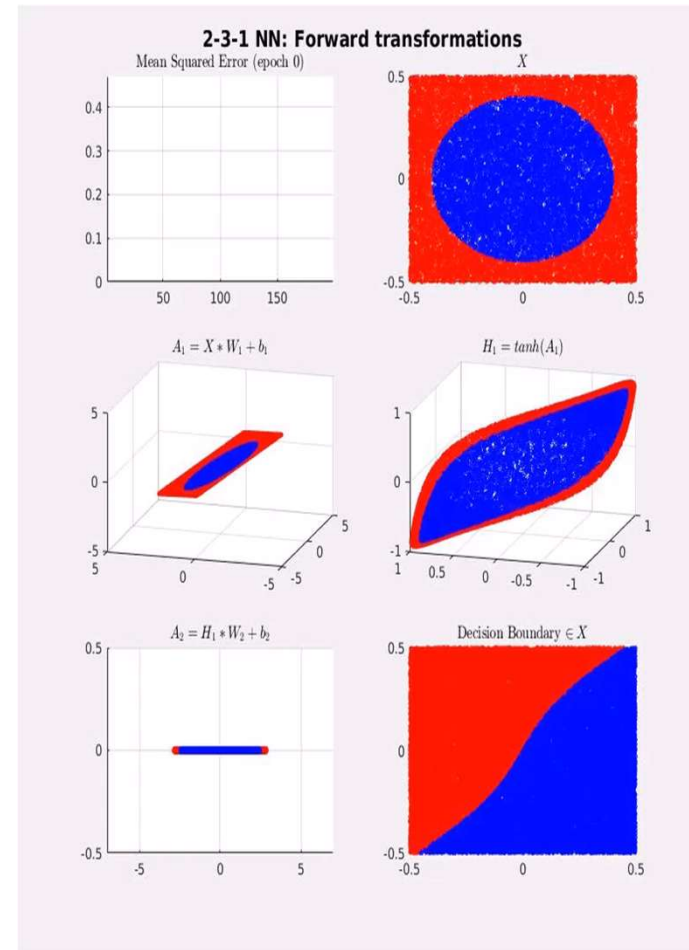
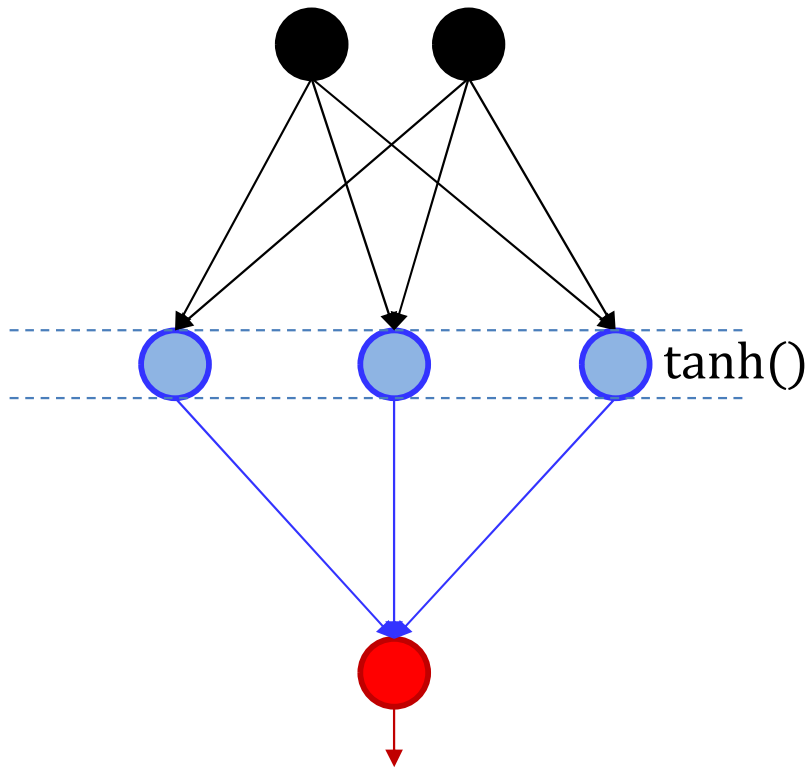
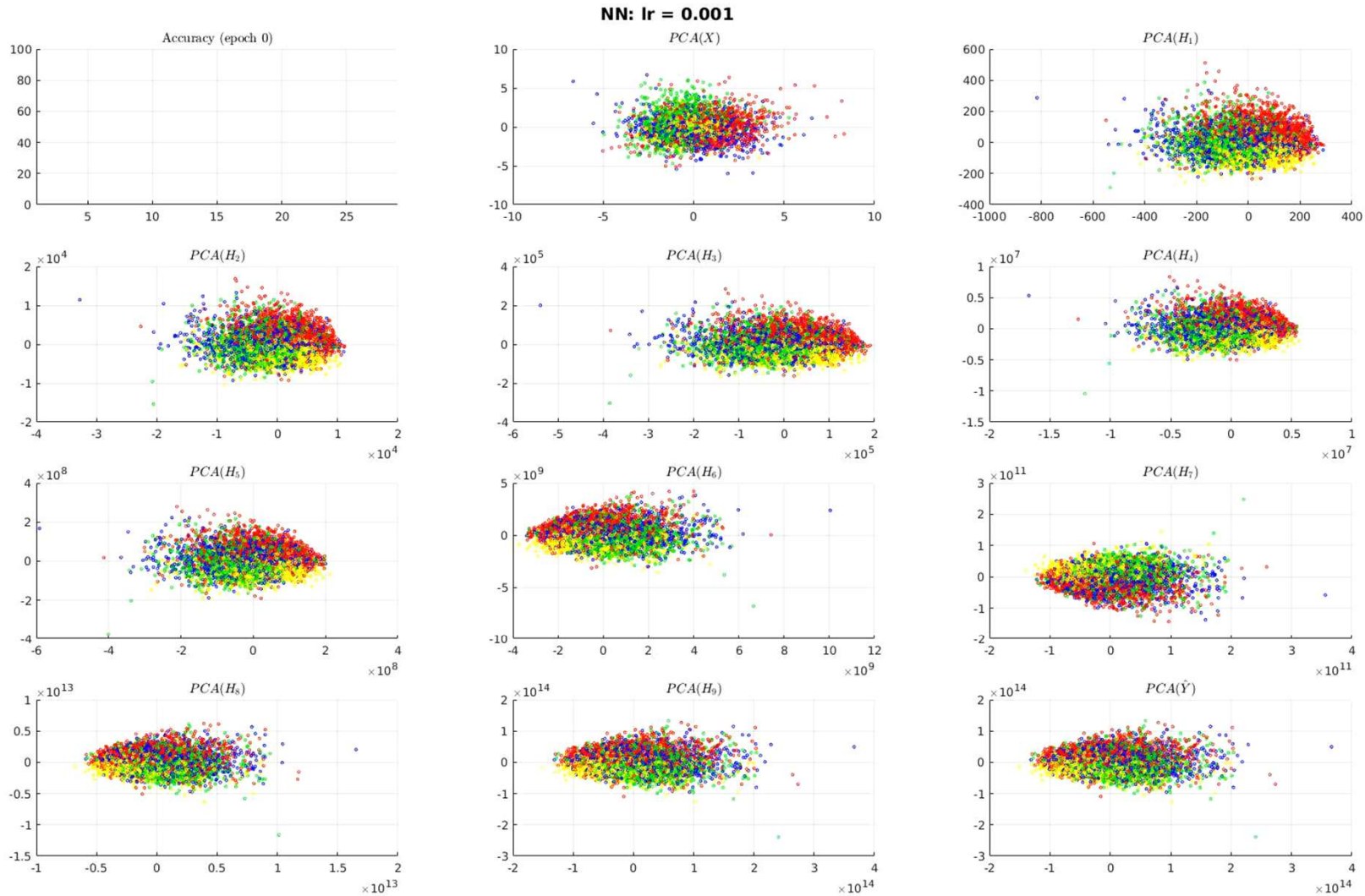

Image courtesy Anders Oland

- Synthetic example: Feature space

The behavior of the layers

Image courtesy Anders Oland



- CIFAR

- Representations become increasingly linearly separable: G. Alain and Y. Bengio, "Understanding intermediate layers using linear classifier probes," in 5th International Conference on Learning Representations, Workshop Track Proceedings, 2017

The behavior of the layers

Image courtesy Anders Oland

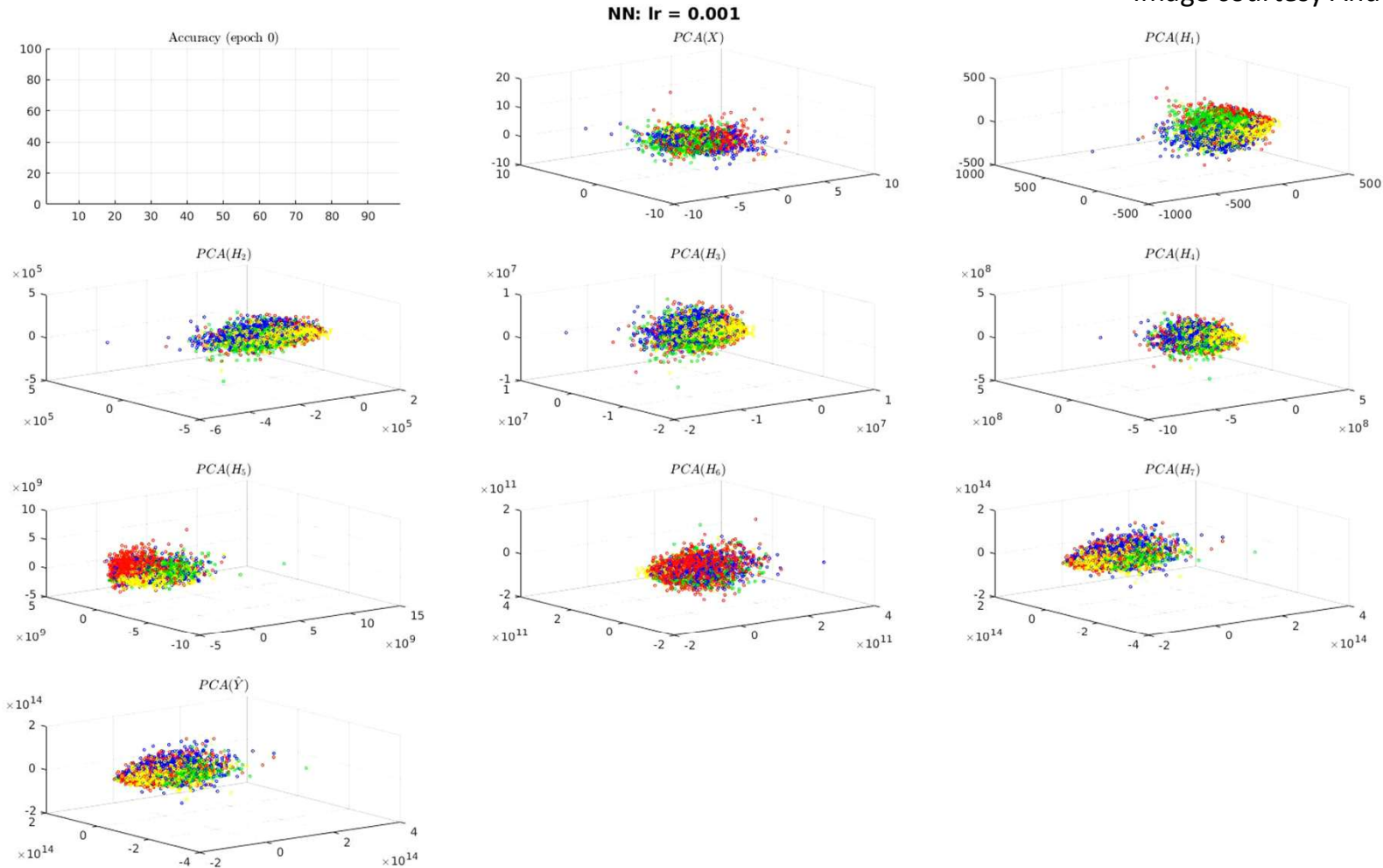

- CIFAR

- Representations become increasingly linearly separable: G. Alain and Y. Bengio, "Understanding intermediate layers using linear classifier probes," in 5th International Conference on Learning Representations, Workshop Track Proceedings, 2017

Everything in this book may be wrong!

- Richard Bach (Illusions)



There's no such thing as inseparable classes

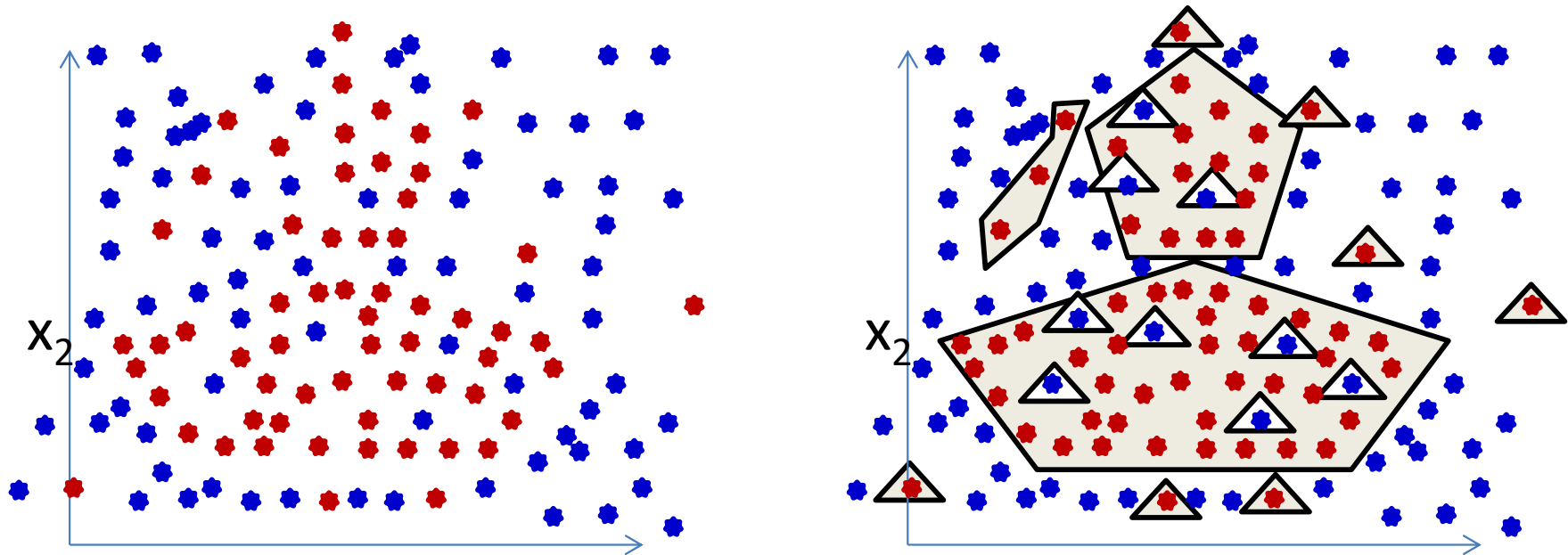

- A sufficiently detailed architecture can separate nearly *any* arrangement of points
 - “Correctness” of the suggested intuitions subject to various parameters, such as regularization, detail of network, training paradigm, convergence etc..

Changing gears..

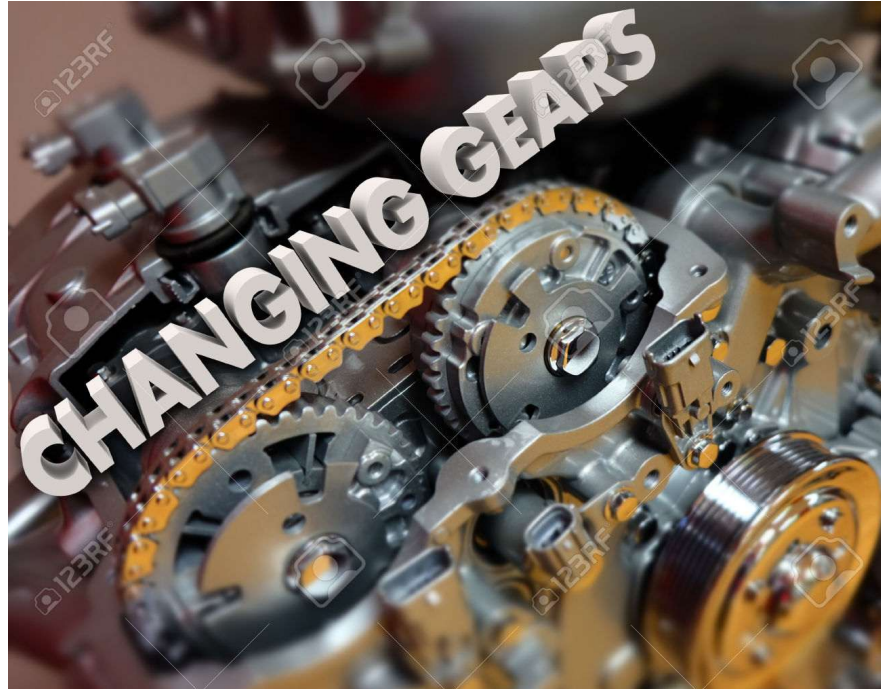

Intermediate layers

We've seen what the network learns here

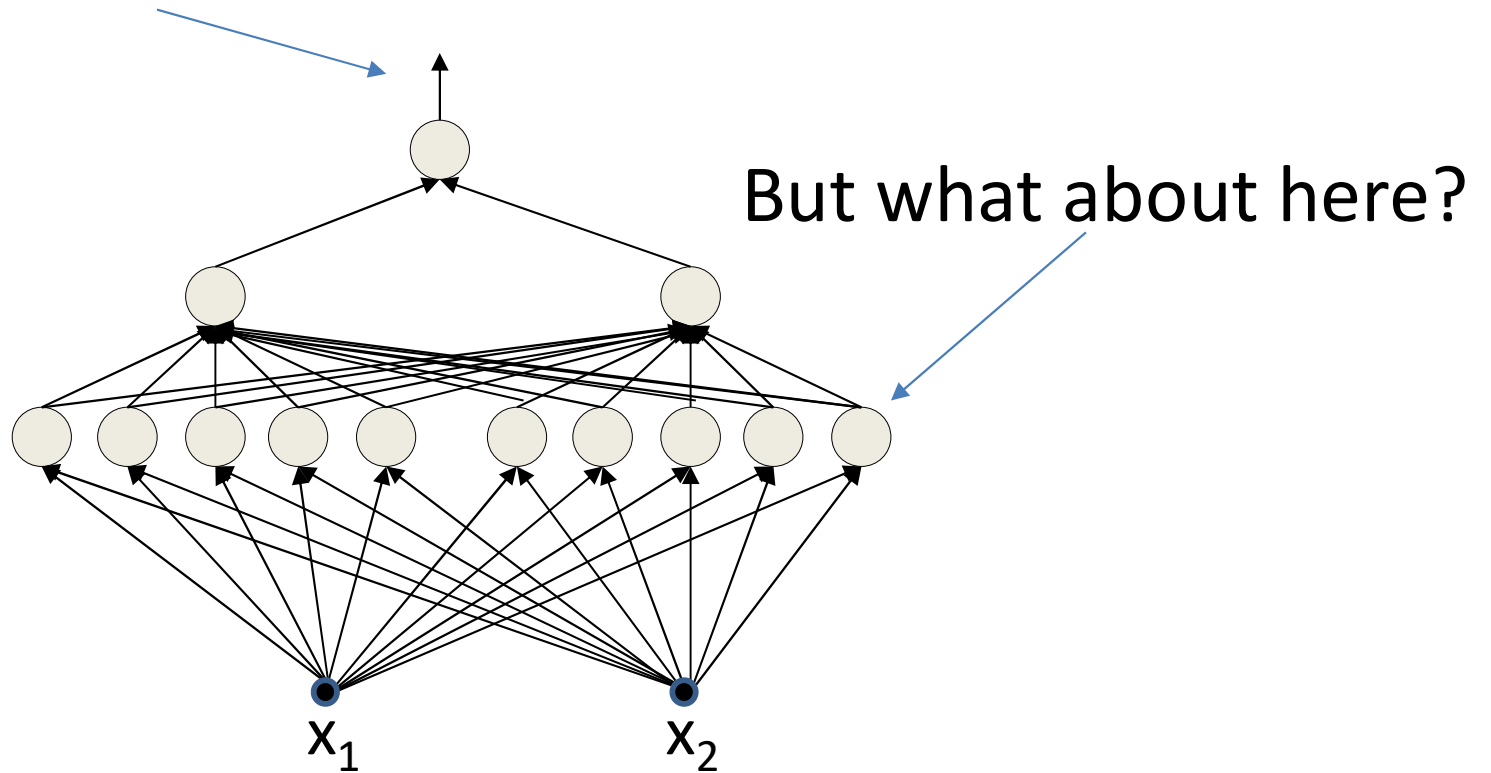

Recall: The basic perceptron

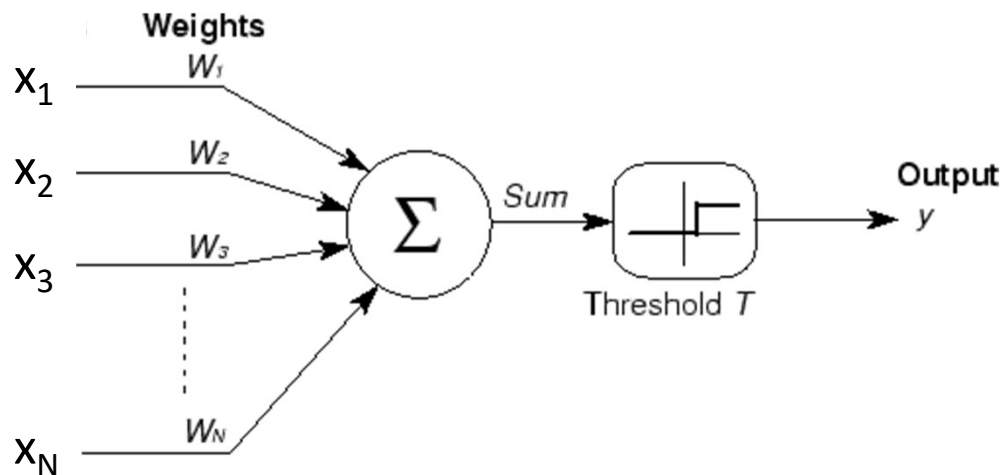

$$y = \begin{cases} 1 & \text{if } \sum_i w_i x_i \geq T \\ 0 & \text{else} \end{cases}$$

$$y = \begin{cases} 1 & \text{if } \mathbf{x}^T \mathbf{w} \geq T \\ 0 & \text{else} \end{cases}$$

- What do the *weights* tell us?
 - The neuron fires if the inner product between the weights and the inputs exceeds a threshold

Recall: The weight as a “template”

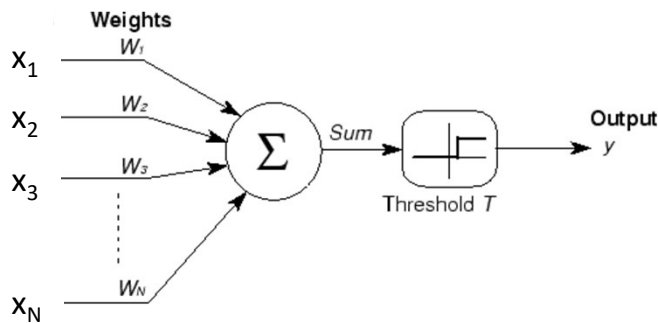

$$X^T W > T$$
$$\cos \theta > \frac{T}{|W||X|}$$
$$\theta < \cos^{-1} \left(\frac{T}{|W||X|} \right)$$

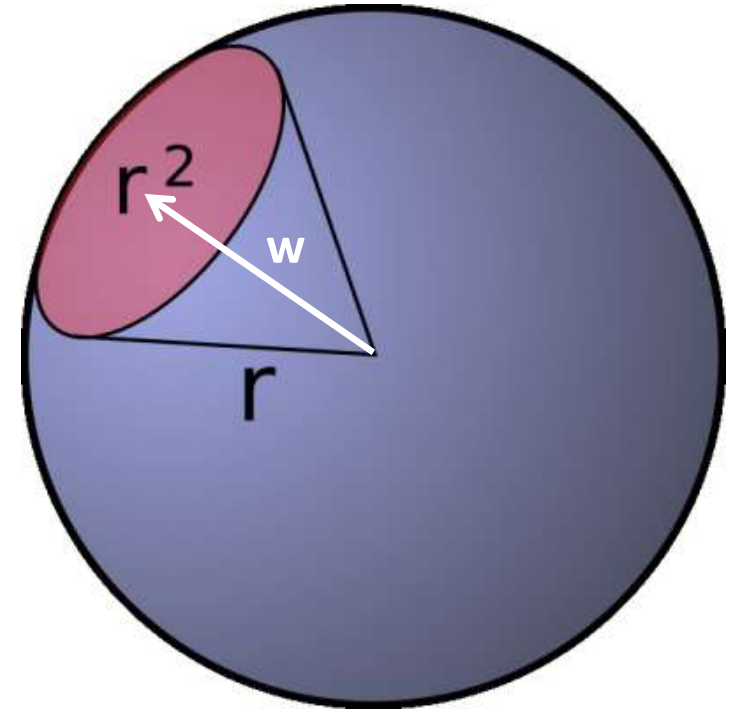

- The perceptron fires if the input is within a specified angle of the weight
- Neuron fires if the input vector is close enough to the weight vector.
 - If the input pattern matches the weight pattern closely enough
 - I.e. If the input pattern and weight pattern are sufficiently correlated

Recall: The weight as a template

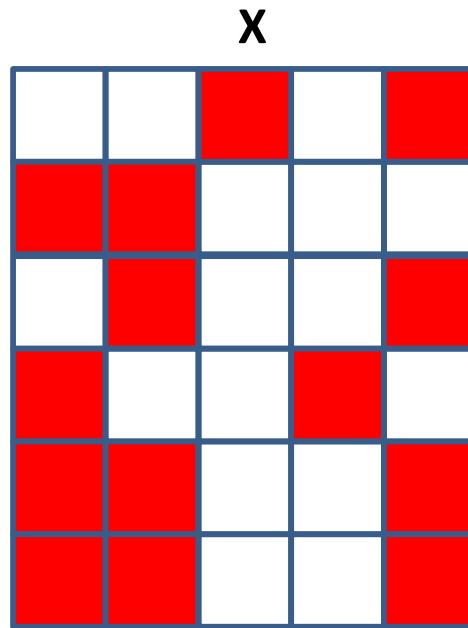
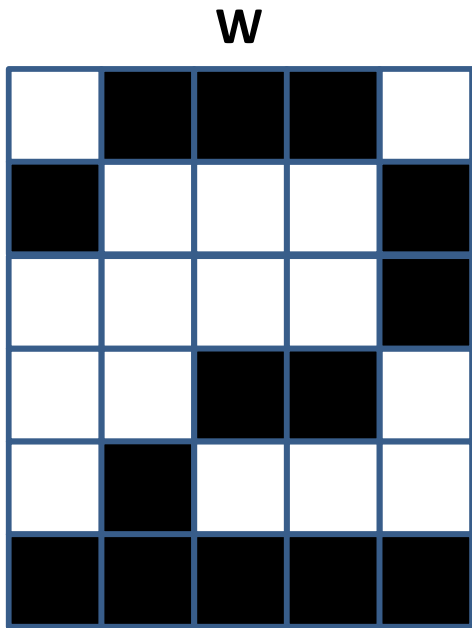

Correlation = 0.57

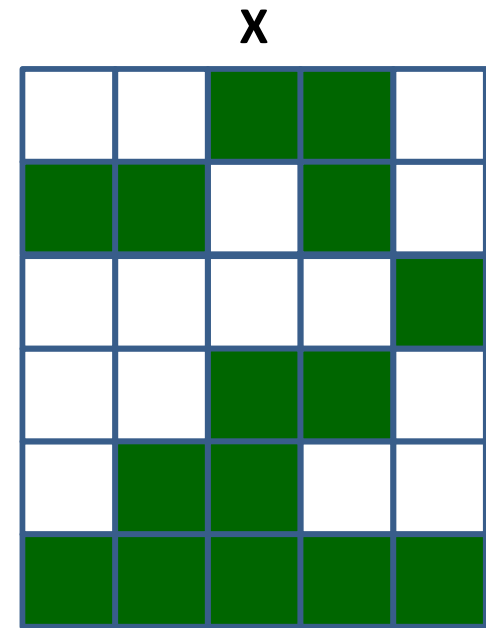

Correlation = 0.82



$$y = \begin{cases} 1 & \text{if } \sum_i w_i x_i \geq T \\ 0 & \text{else} \end{cases}$$

- If the *correlation* between the weight pattern and the inputs exceeds a threshold, fire
- The perceptron is a *correlation filter*!

Recall: MLP features

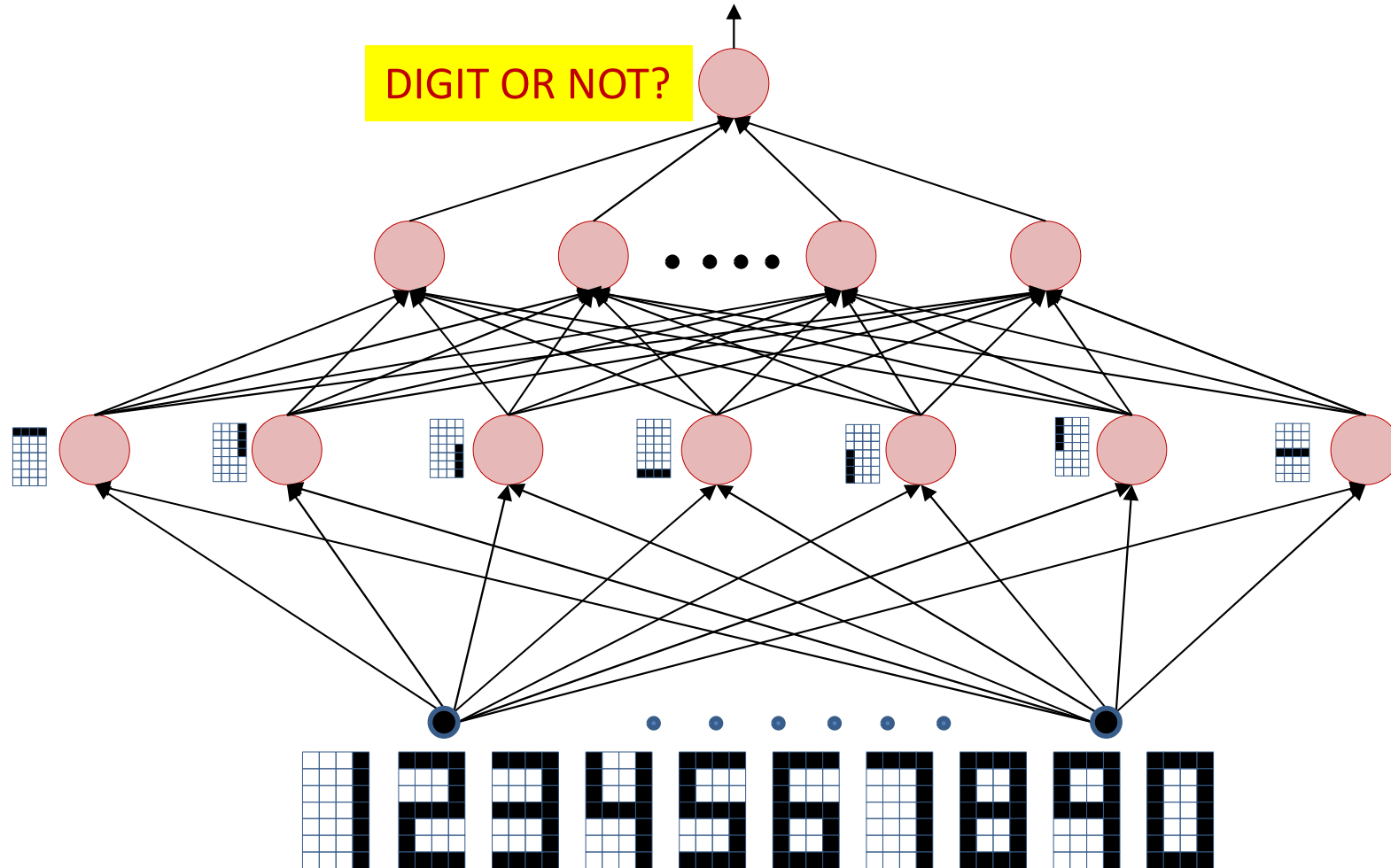

- The lowest layers of a network detect significant features in the signal
- **The signal could be (partially) reconstructed using these features**
 - Will retain all the significant components of the signal

Making it explicit

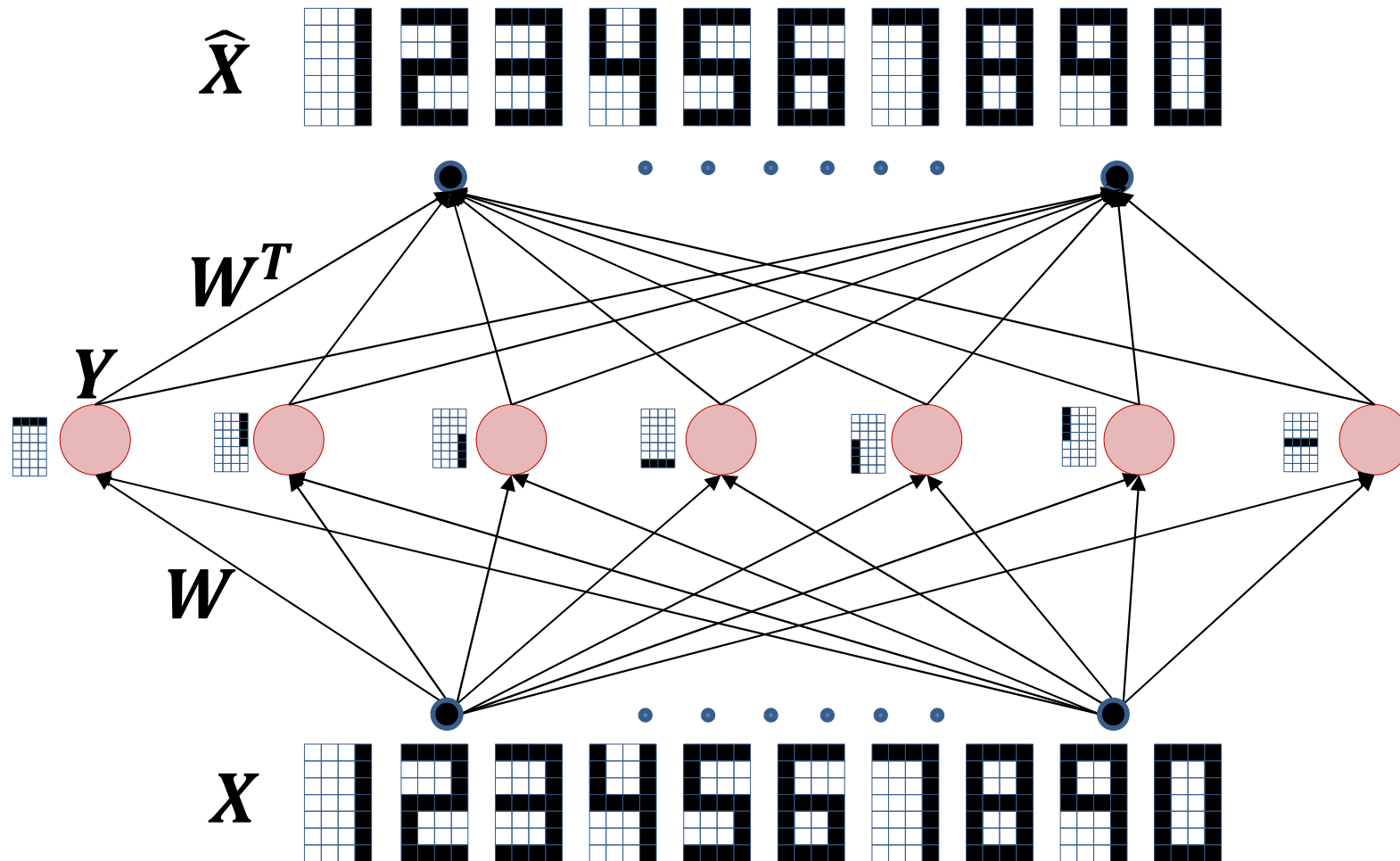

- **The signal could be (partially) reconstructed using these features**
 - Will retain all the significant components of the signal
- Simply *recompose* the detected features
 - Will this work?

Making it explicit

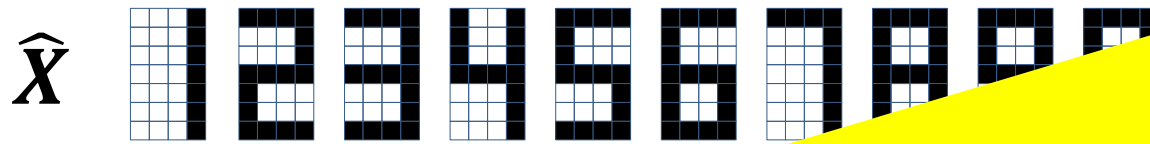

Not in this problem.

The network is optimized to recognize digits

Will only retain distinctly digit-like or obviously not-digit like features

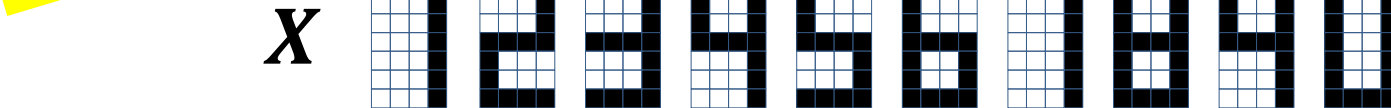

- **The signal could be (partially) reconstructed using these features**
 - Will retain all the significant components of the signal
- Simply *recompose* the detected features
 - Will this work?

Making it explicit: an autoencoder

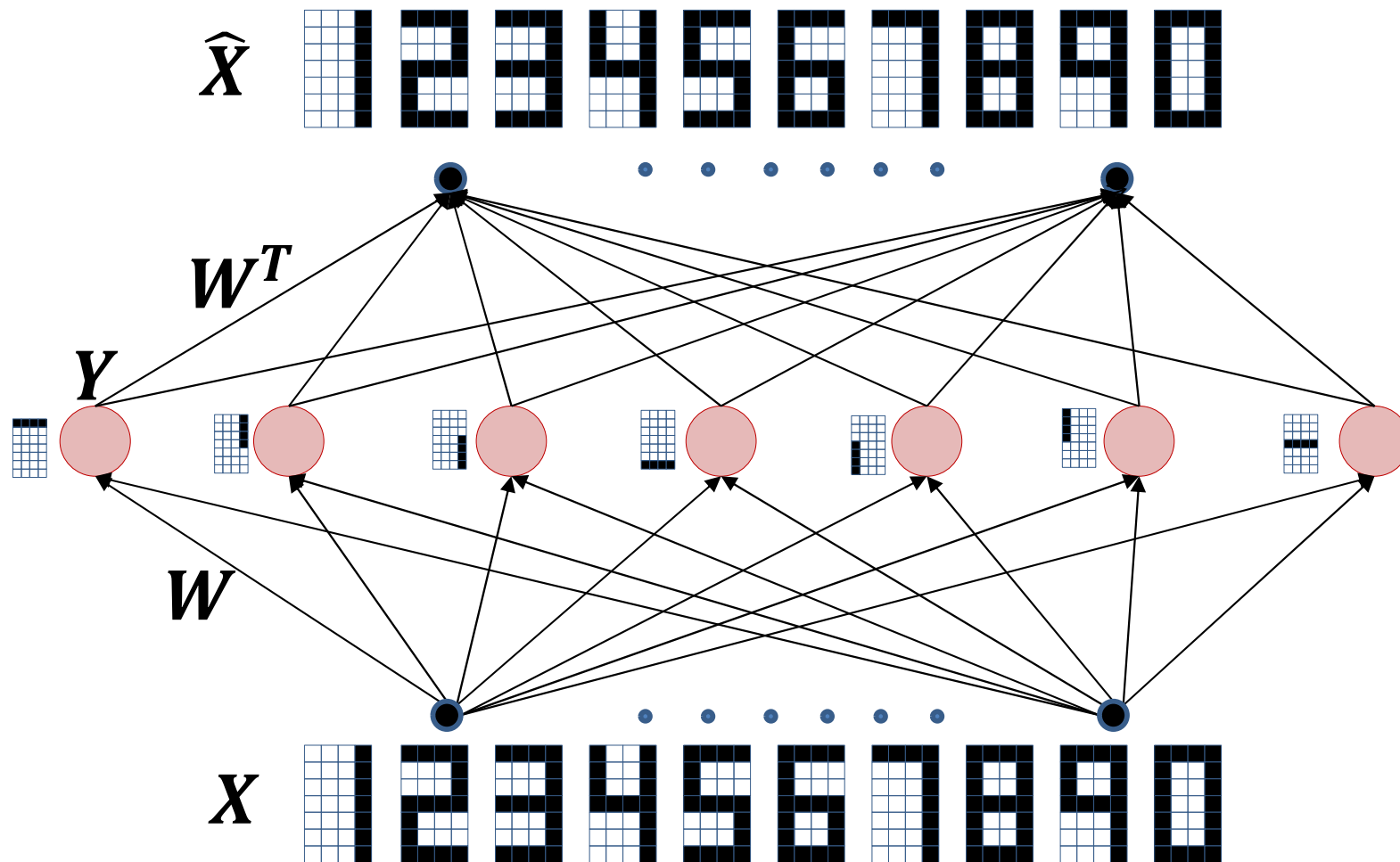

- A neural network can be trained to predict the input itself
- This is an *autoencoder*
- An *encoder* learns to detect all the most significant patterns in the signals
- A *decoder* recomposes the signal from the patterns

The Simplest Autencoder

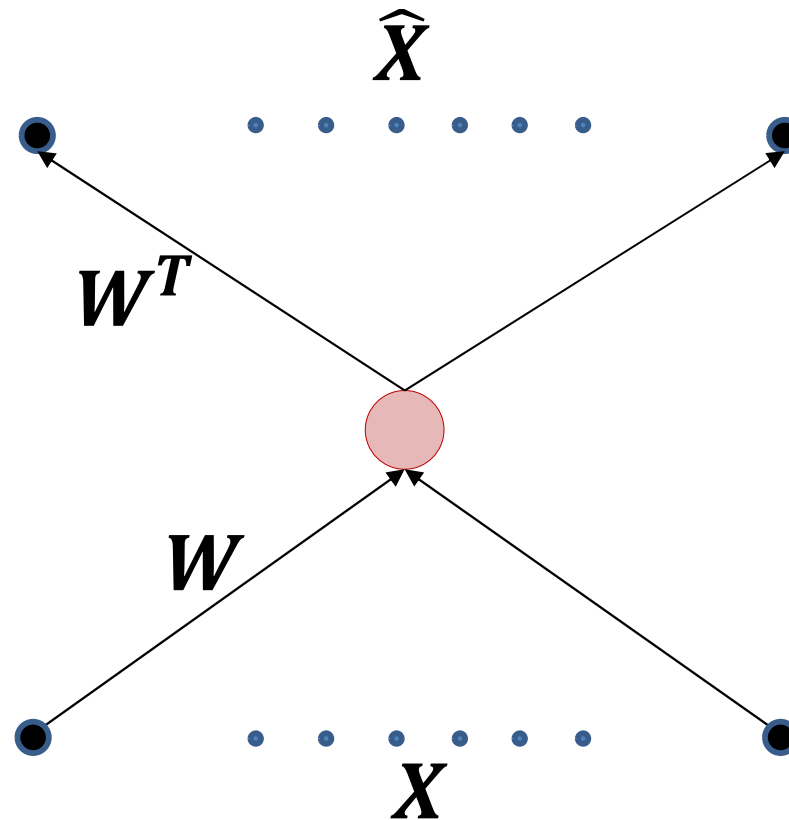

- A single hidden unit
- Hidden unit has *linear* activation
- What will this learn?

The Simplest Autencoder

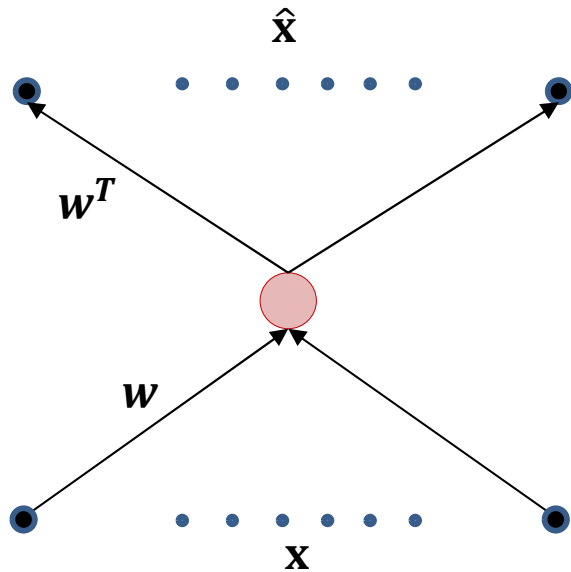

Training: Learning W by minimizing L2 divergence

$$\hat{x} = w^T w x$$

$$div(\hat{x}, x) = \|x - \hat{x}\|^2 = \|x - w^T w x\|^2$$

$$\hat{W} = \underset{W}{\operatorname{argmin}} E[div(\hat{x}, x)]$$

$$\hat{W} = \underset{W}{\operatorname{argmin}} E[\|x - w^T w x\|^2]$$

- This is just PCA!

The Simplest Autencoder

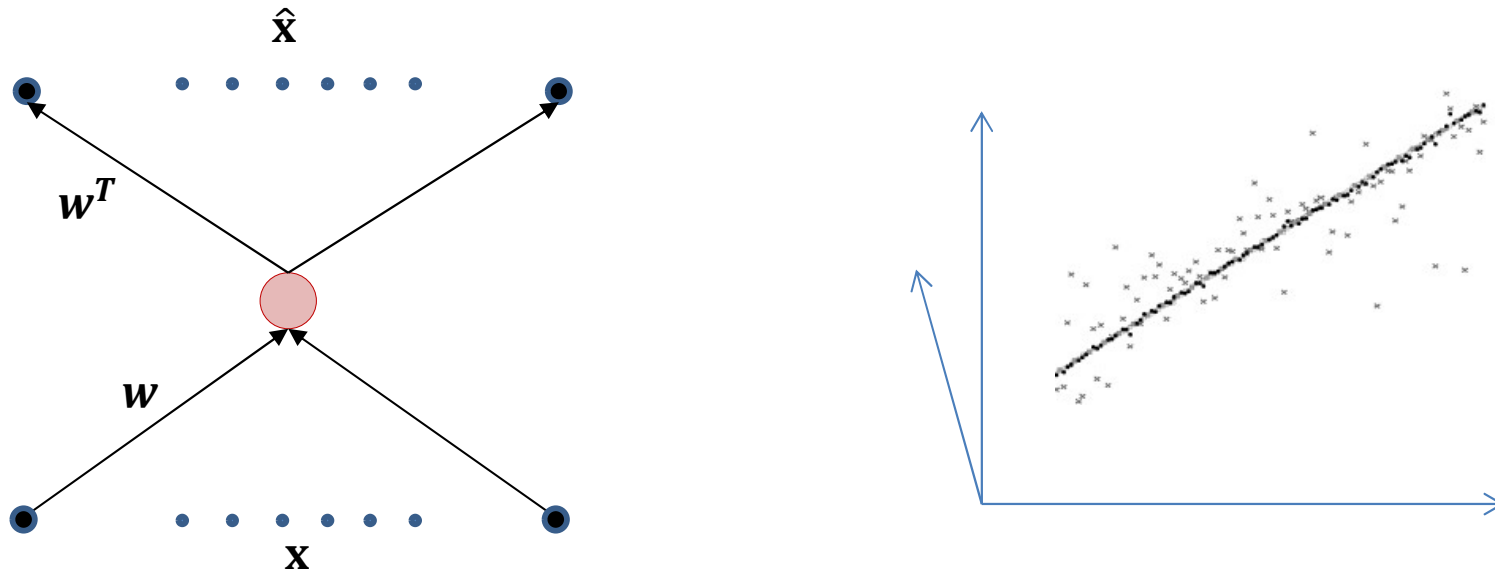

- The autoencoder finds the direction of maximum energy
 - Variance if the input is a zero-mean RV
- All input vectors are mapped onto a point on the principal axis

The Simplest Autencoder

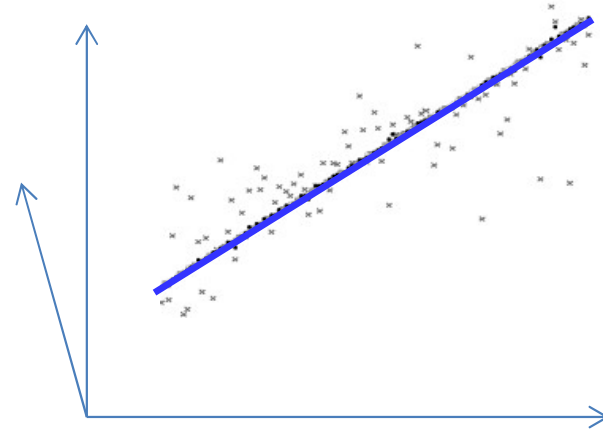
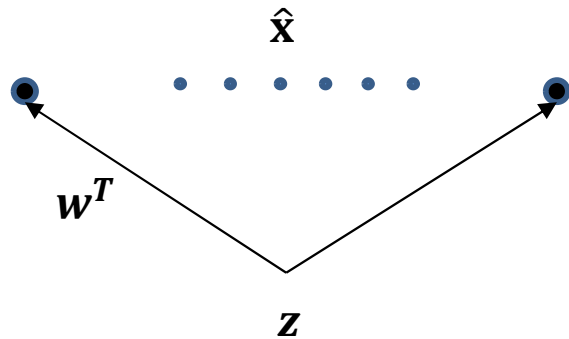

- Simply varying the hidden representation will result in an output that lies along the major axis

The Simplest Autencoder

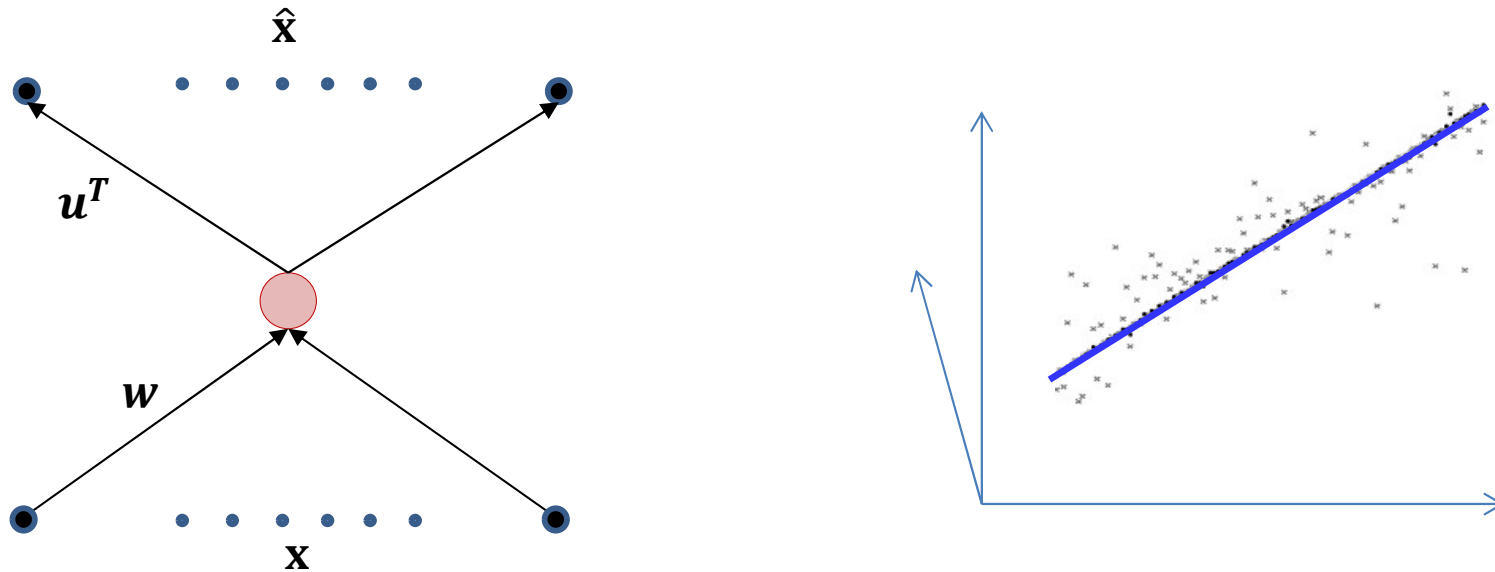

- Simply varying the hidden representation will result in an output that lies along the major axis
- This will happen even if the learned output weight is separate from the input weight
 - The minimum-error direction *is* the principal eigen vector

For more detailed AEs without a non-linearity

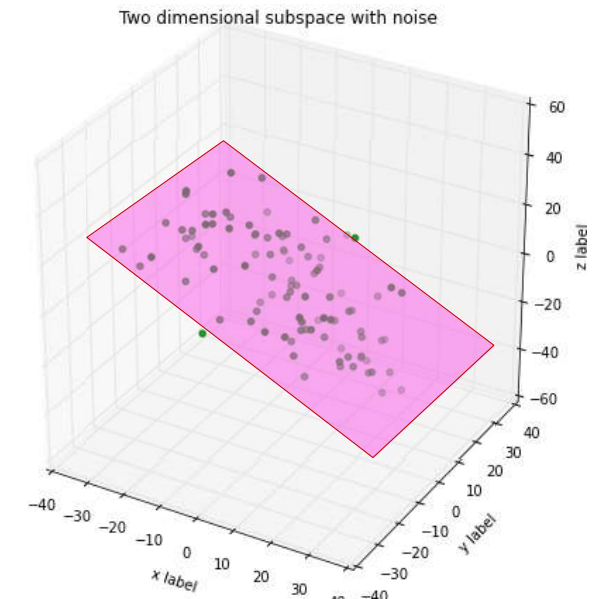
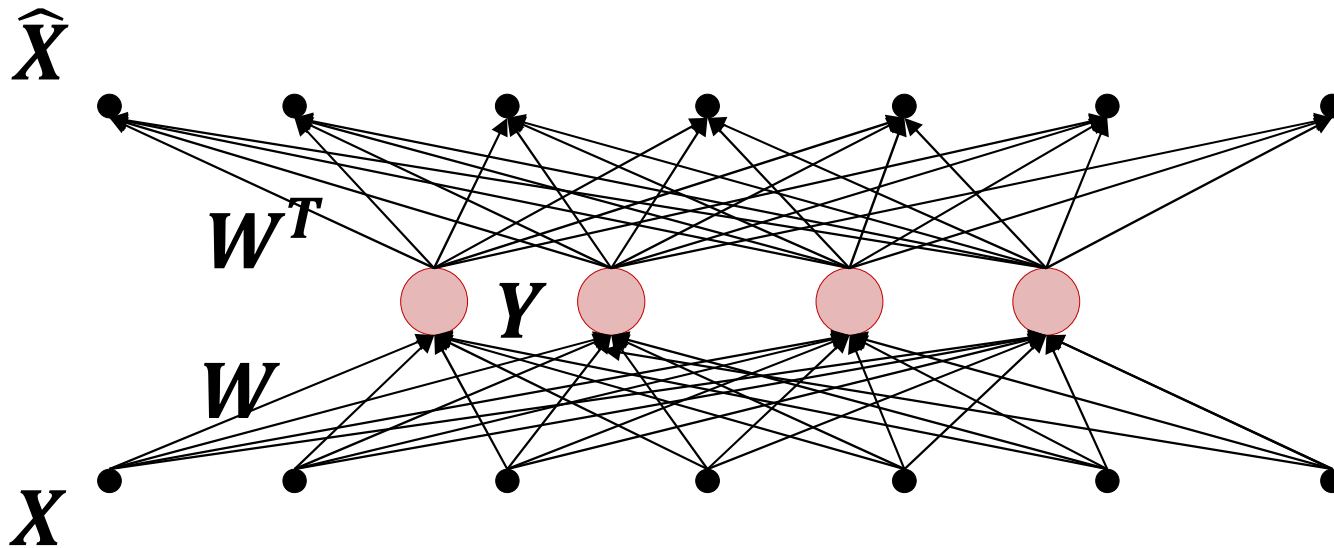

$$Y = WX$$

$$\hat{X} = W^T Y$$

$$E = \|X - W^T W X\|^2 \quad \text{Find } W \text{ to minimize Avg}[E]$$

- This is still just PCA
 - The output of the hidden layer will be in the principal subspace
 - Even if the recomposition weights are different from the “analysis” weights

Poll 3 (@1058, @1059)

An autoencoder with a linear activation in the hidden layer performs Principal Component Analysis of the input, True or False

- True
- False

An autoencoder with linear activations in the hidden layer, that has been trained on some data can only output values on the principal subspace of that data, regardless of the input

- True
- False

Poll 3

An autoencoder with a linear activation in the hidden layer performs Principal Component Analysis of the input, True or False

- **True**
- False

An autoencoder with linear activations in the hidden layer, that has been trained on some data can only output values on the principal subspace of that data, regardless of the input

- **True**
- False

Terminology

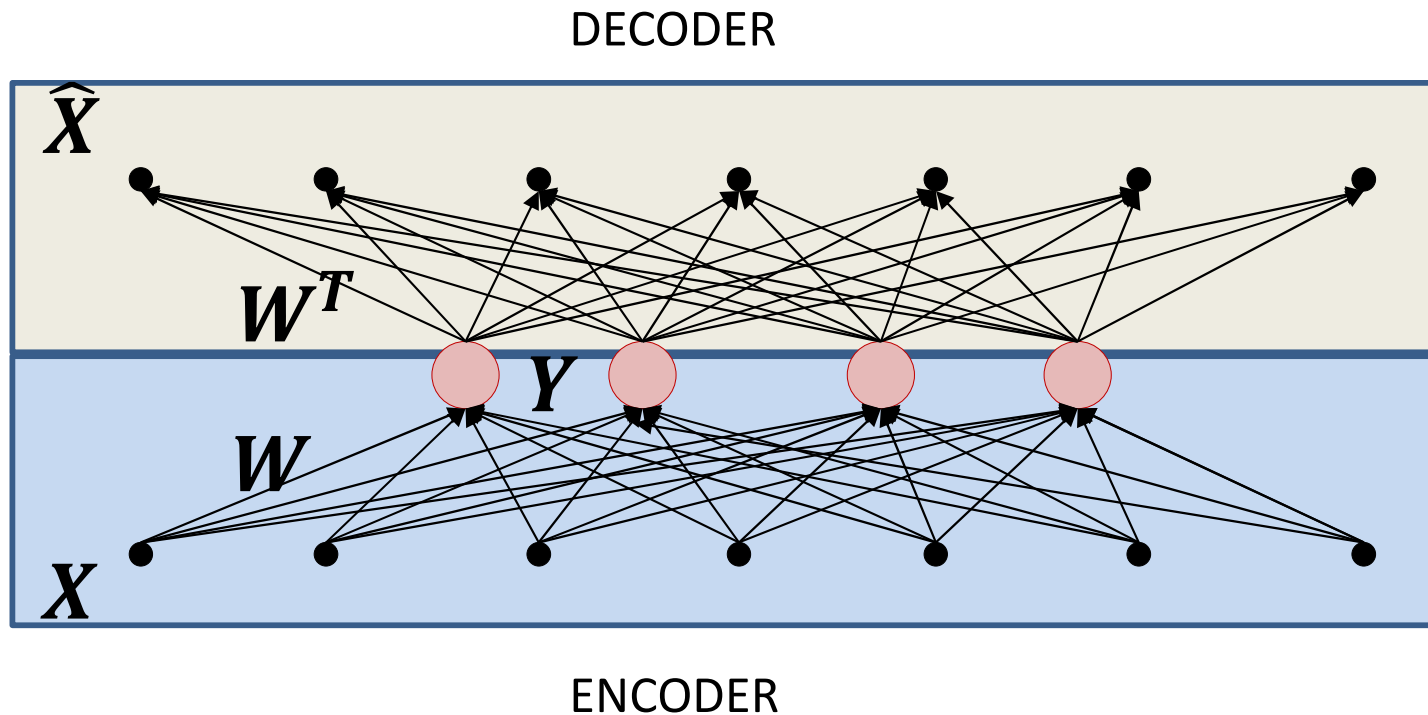

- Terminology:
 - **Encoder:** The “Analysis” net which computes the hidden representation
 - **Decoder:** The “Synthesis” which recomposes the data from the hidden representation

Introducing *nonlinearity*

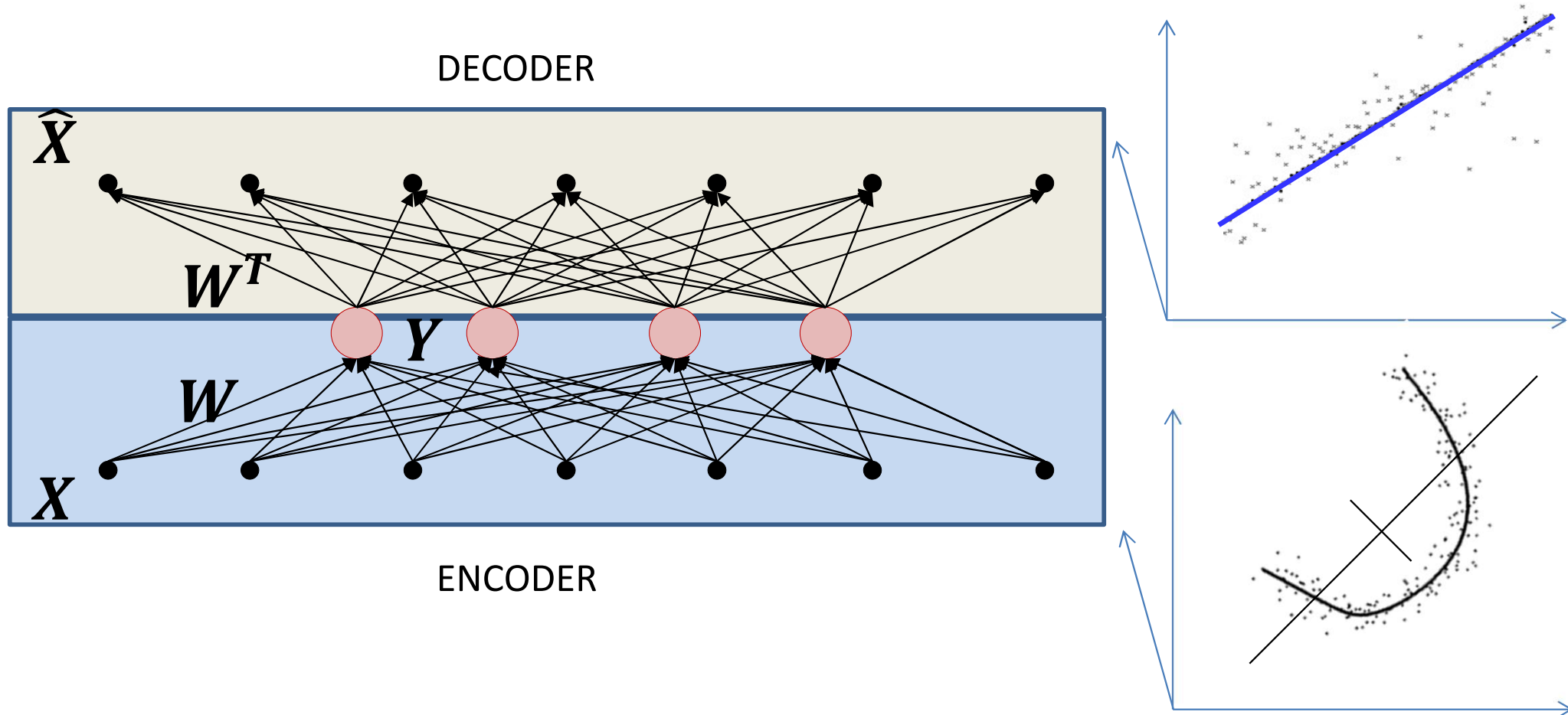

- When the decoder layer has a *linear* activation, it represents the best *linear* manifold to fit the data
 - Varying the hidden value will move along this linear manifold
- **When the decoder layers have non-linear activations, the net performs *nonlinear PCA***
 - The decoder represents the best non-linear manifold to fit the data
 - Varying the hidden value will move along this non-linear manifold

The AE

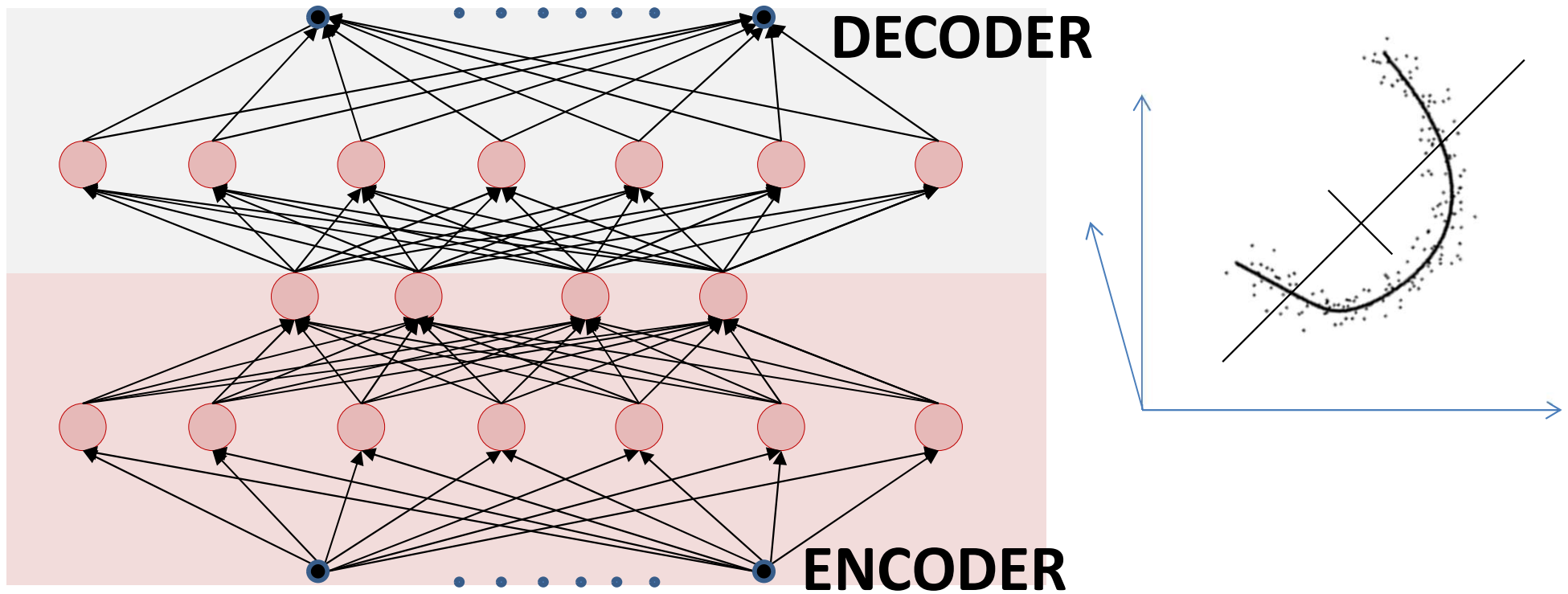

- With non-linearity
 - “Non linear” PCA
 - Deeper networks can capture more complicated manifolds
 - “Deep” autoencoders

Some examples

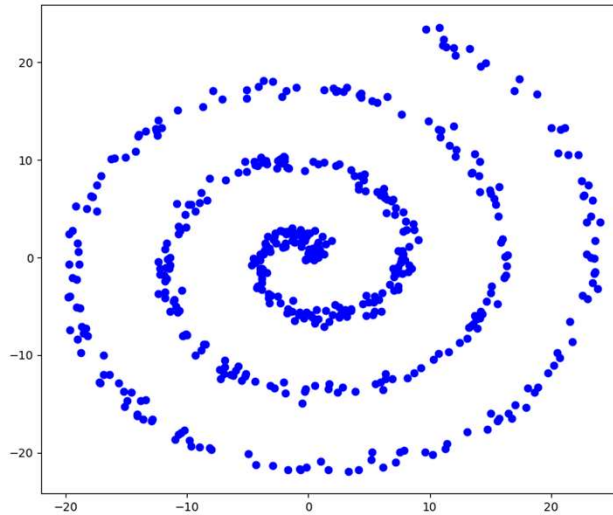
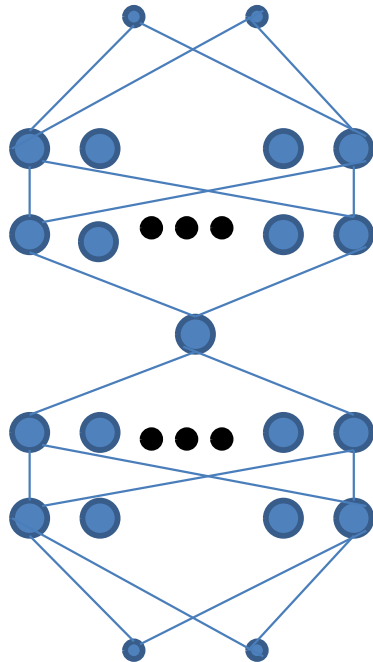

Encoder is an MLP with 5 residual blocks, each with 64 hidden units.
Two fully-connected layers (2x64, 64, 1).
Decoder is the mirror image.
All non-linearities are exponential linear units (ELU)

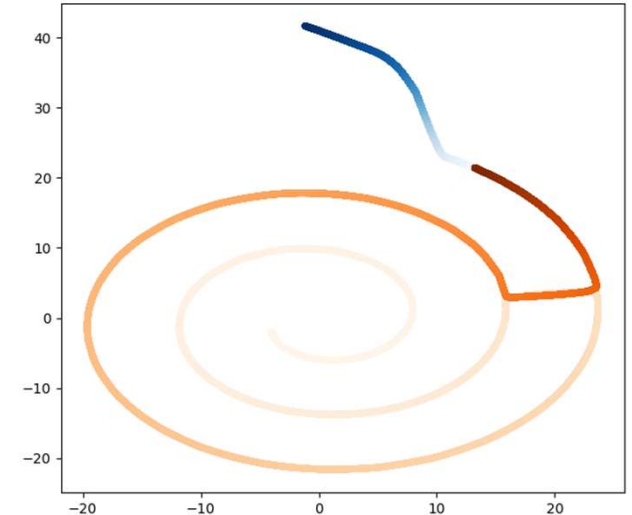

- 2-D input
- Encoder and decoder have 2 hidden layers of 100 neurons, but hidden representation is unidimensional
- Extending the hidden “z” value beyond the values seen in training does not continue along a helix

Some examples

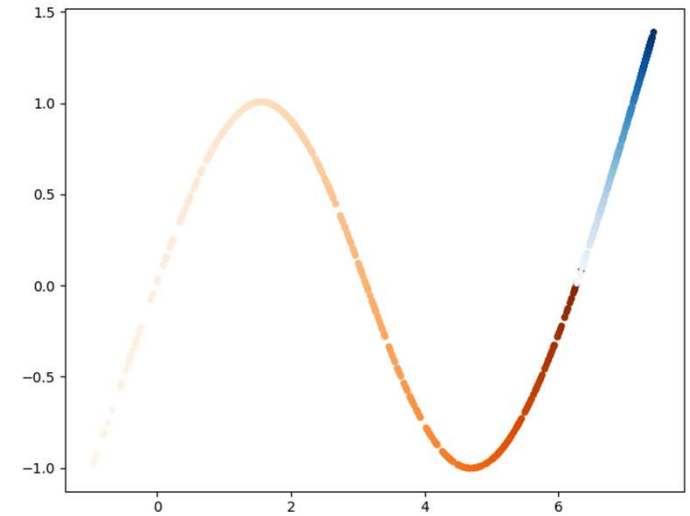
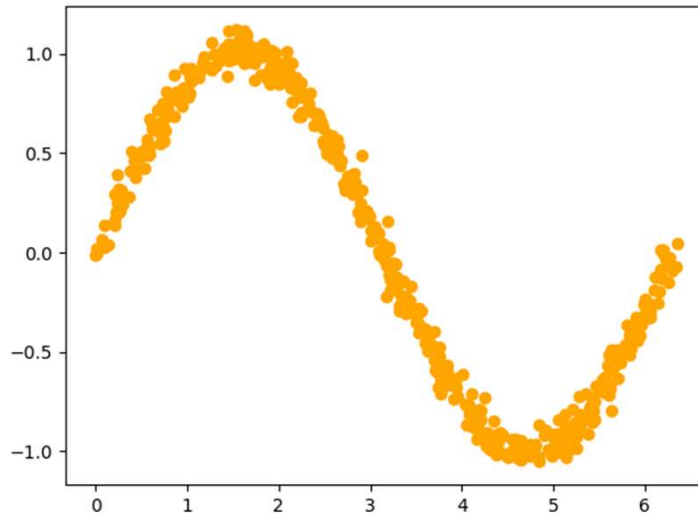
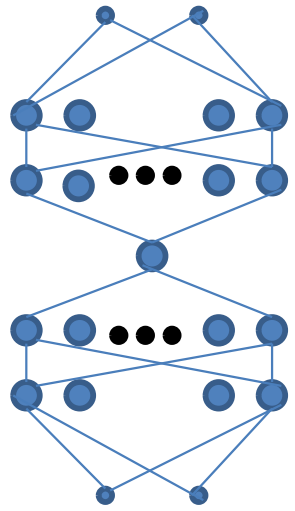

- The model is specific to the training data..
 - Varying the hidden layer value only generates data along the learned manifold
 - *Any input* will result in an output along the learned manifold
 - But may not generalize beyond the manifold

The AE

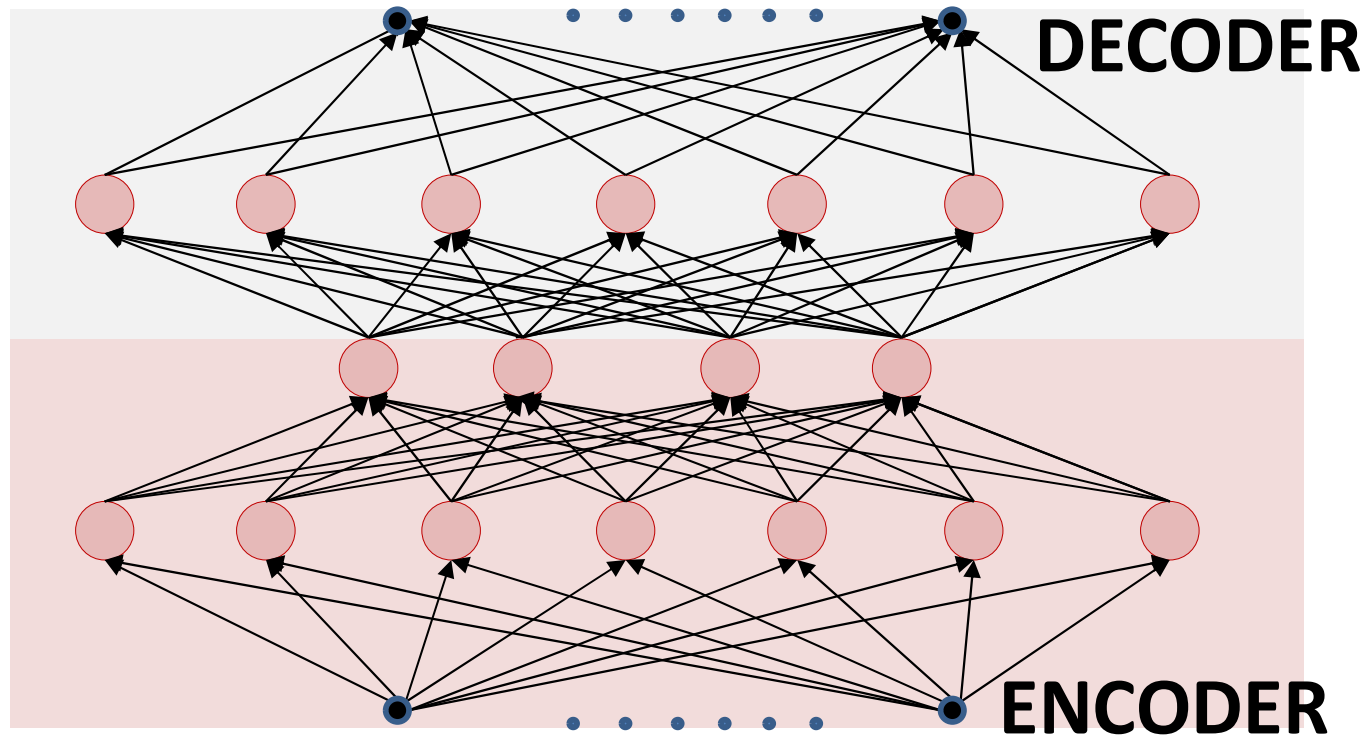

- When the hidden representation is of lower dimensionality than the input, often called a “**bottleneck**” network
 - Nonlinear PCA
 - Learns the manifold for the data
 - If properly trained

The AE

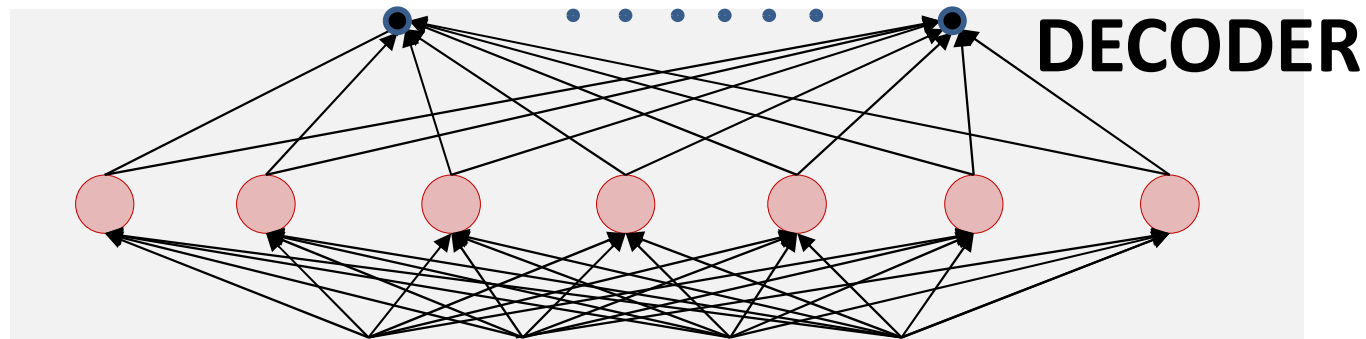

- The decoder can only generate data on the manifold that the training data lie on
- This also makes it an excellent “generator” of the distribution of the training data
 - Any values applied to the (hidden) input to the decoder will produce data similar to the training data

The Decoder:

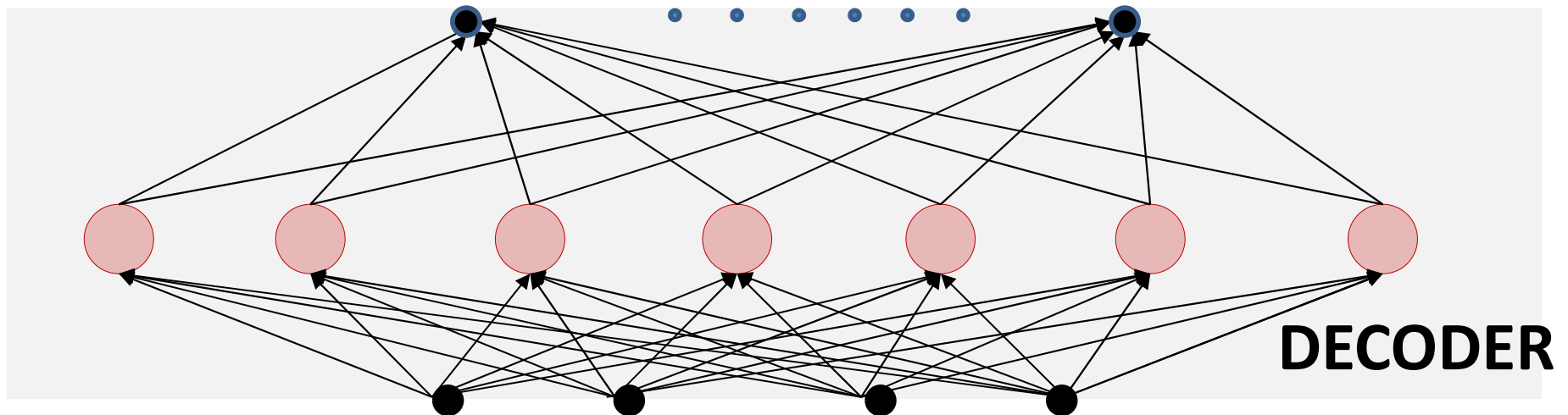
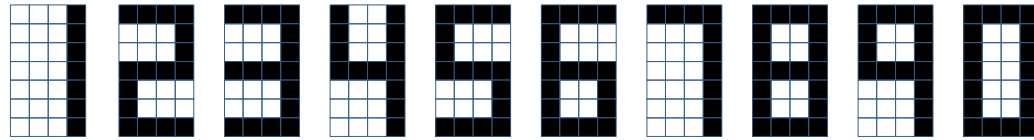

- The decoder represents a source-specific generative *dictionary*
- Exciting it will produce typical data from the source!

The Decoder:



Sax dictionary

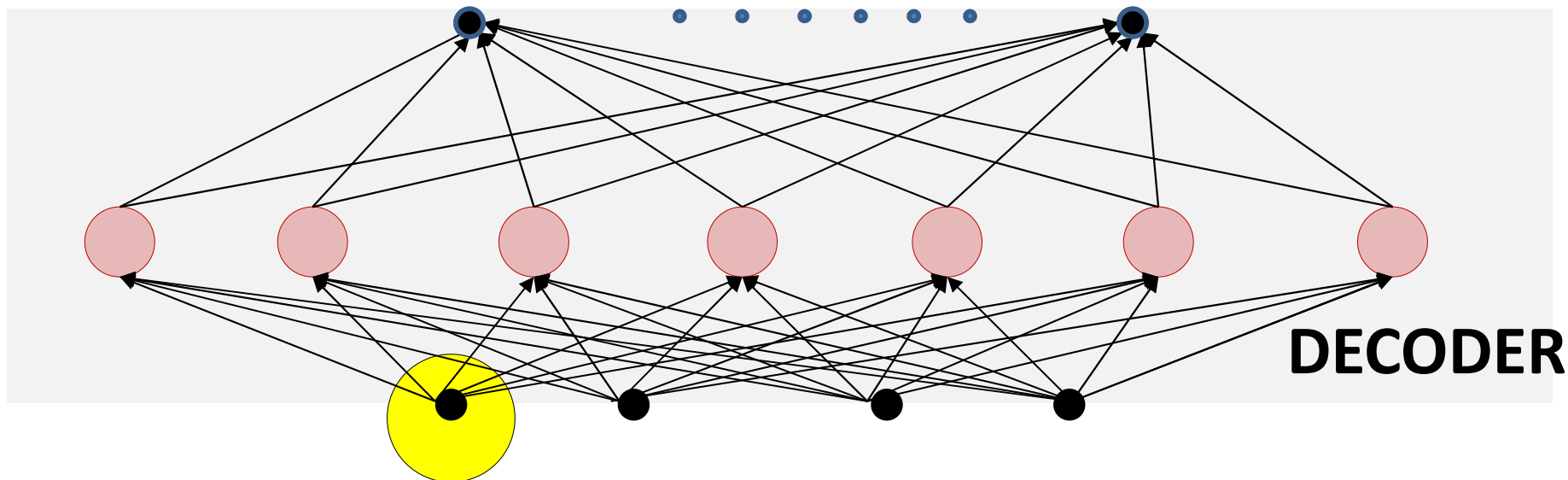

- The decoder represents a source-specific generative *dictionary*
- Exciting it will produce typical data from the source!

The Decoder:



Clarinet dictionary

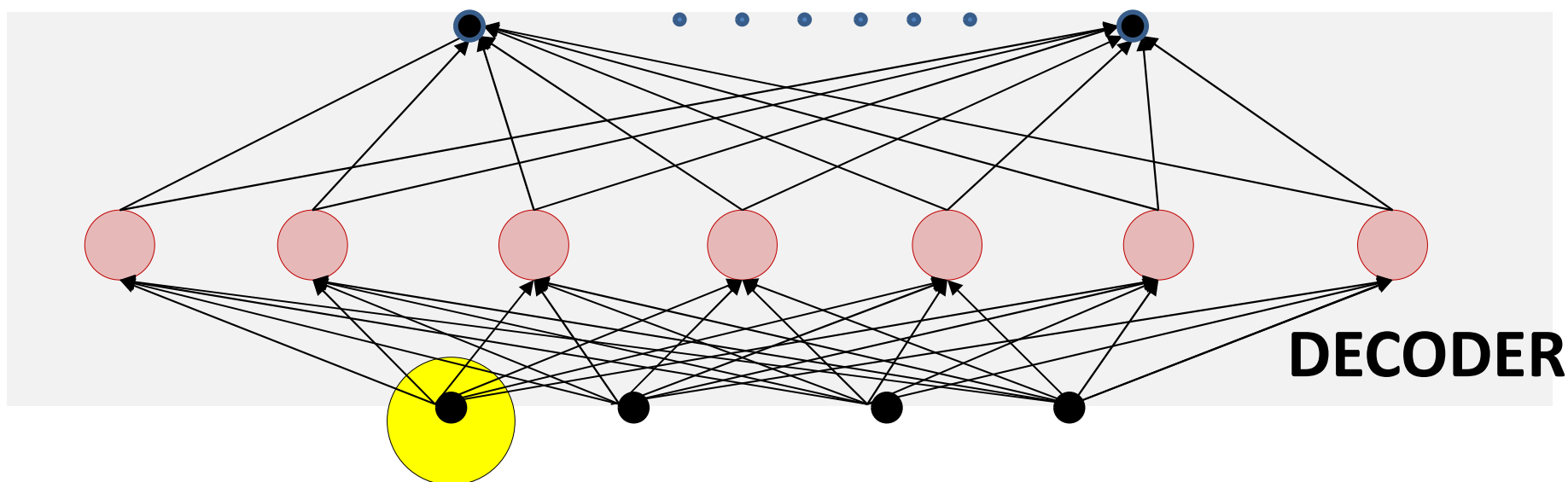

- The decoder represents a source-specific generative *dictionary*
- Exciting it will produce typical data from the source!

Poll 4 (@1060)

Select all that are true of autoencoders with non-linear activations

- An autoencoder with nonlinear activation performs non-linear principal component analysis of the training data
- It finds the principal manifold (surface, which may not be linear) near which the training data lies
- The decoder of the non-linear AE can only generate data on the principal manifold of the training data regardless of the input
- The decoder of the non-linear AE is a “dictionary” which composes data like the training data, in response to any input

Poll 4

Select all that are true of autoencoders with non-linear activations

- An autoencoder with nonlinear activation performs non-linear principal component analysis of the training data
- It finds the principal manifold (surface, which may not be linear) near which the training data lies
- The decoder of the non-linear AE can only generate data on the principal manifold of the training data regardless of the input
- The decoder of the non-linear AE is a “dictionary” which composes data like the training data, in response to any input

A cute application..

- Signal separation...
- Given a mixed sound from multiple sources, separate out the sources

Dictionary-based techniques

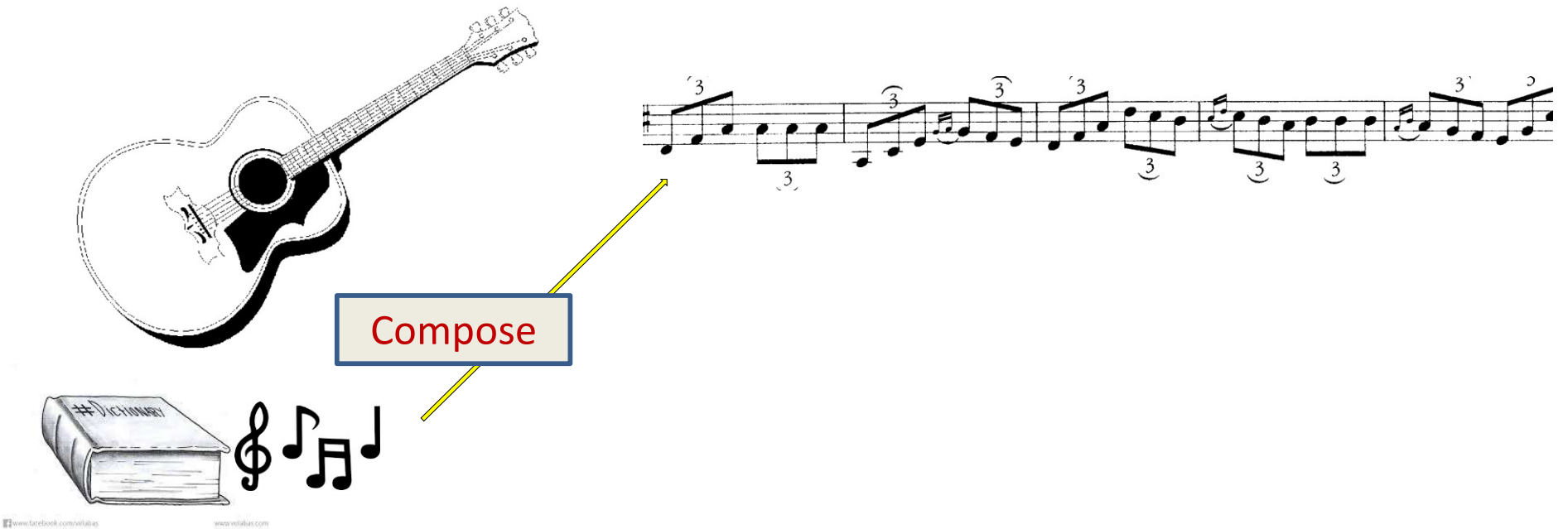

- Basic idea: Learn a dictionary of “building blocks” for each sound source
- All signals by the source are composed from entries from the dictionary for the source

Dictionary-based techniques

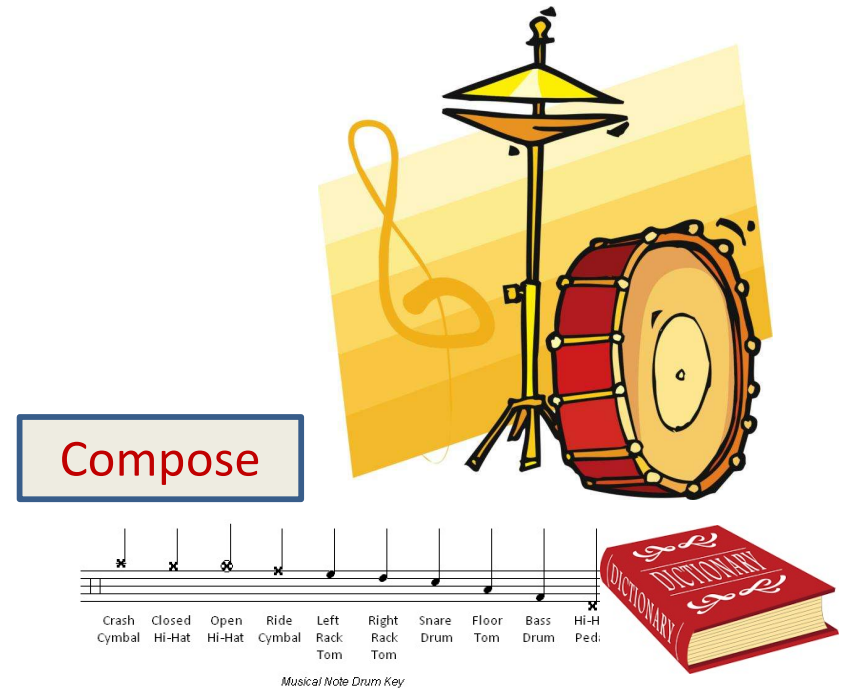

- Learn a similar dictionary for all sources expected in the signal

Dictionary-based techniques

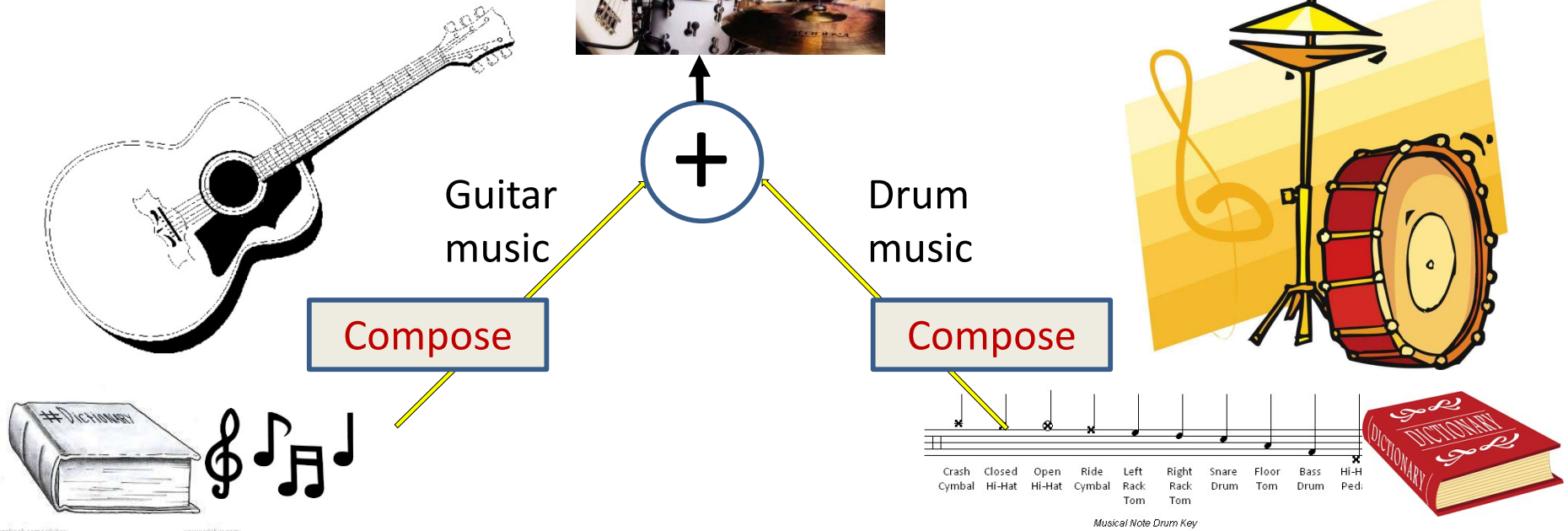

- A mixed signal is the linear combination of signals from the individual sources
 - Which are in turn composed of entries from its dictionary

Dictionary-based techniques

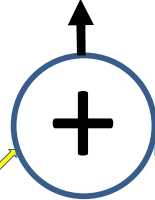
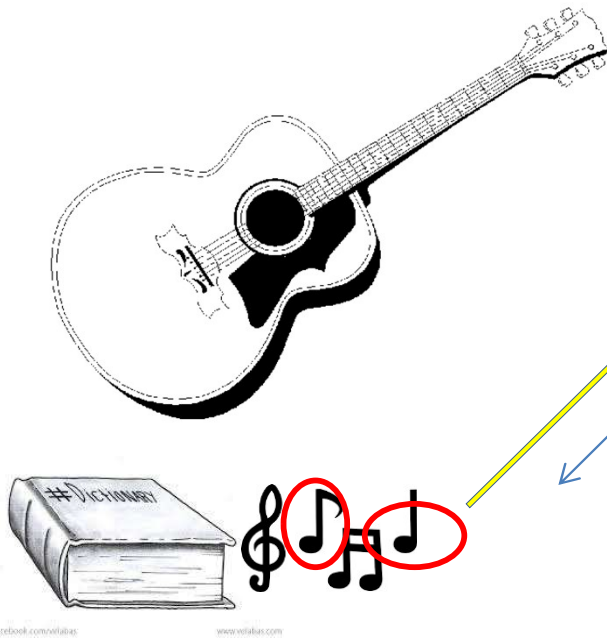
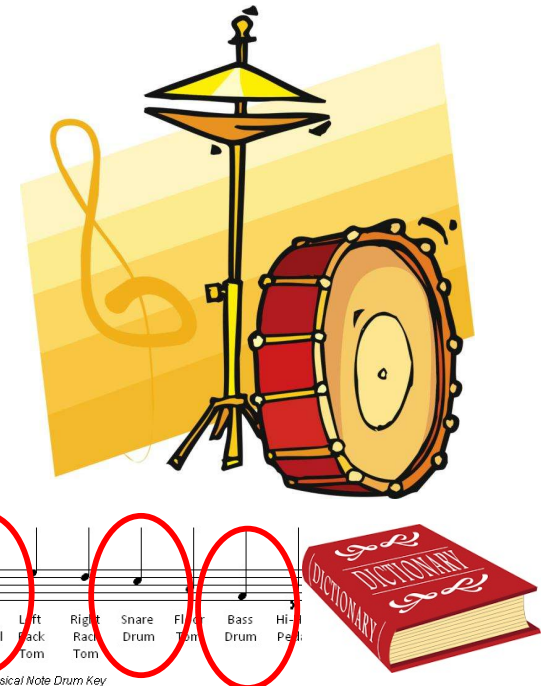

- Separation: Identify the combination of entries from both dictionaries that compose the mixed signal

Dictionary-based techniques

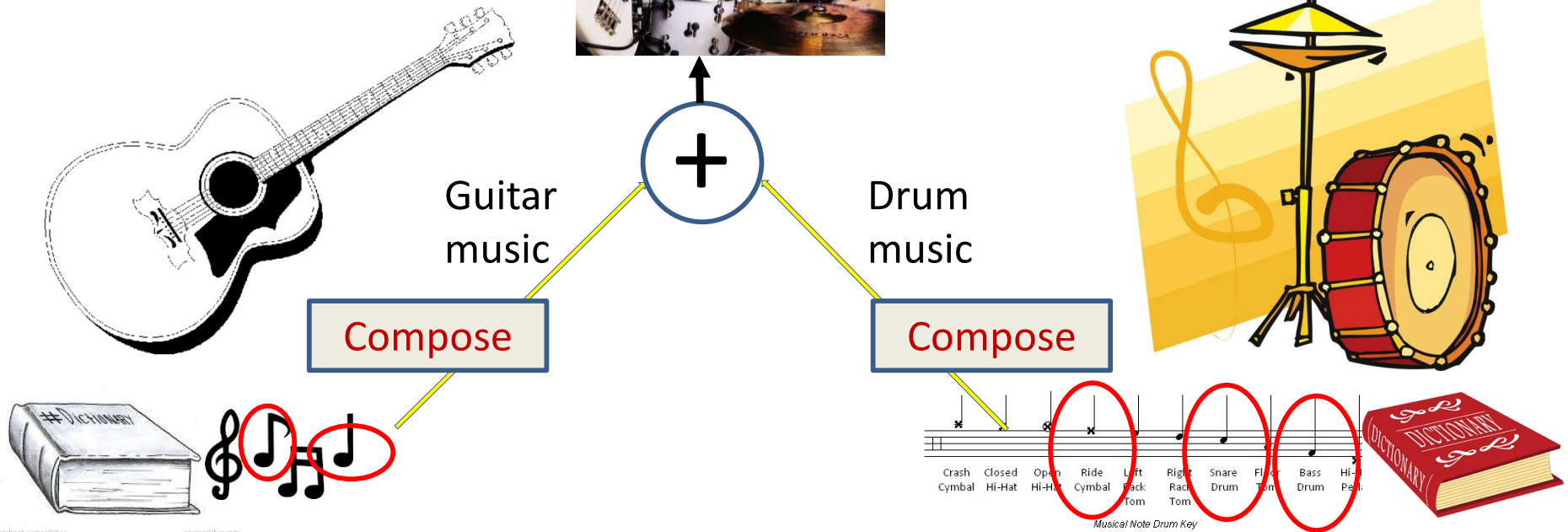

- Separation: Identify the combination of entries from both dictionaries that compose the mixed signal
 - The composition from the identified dictionary entries gives you the separated signals

Learning Dictionaries



- Autoencoder dictionaries for each source
 - Operating on (magnitude) spectrograms
- For a well-trained network, the “decoder” dictionary is highly specialized to creating sounds for that source

Model for mixed signal

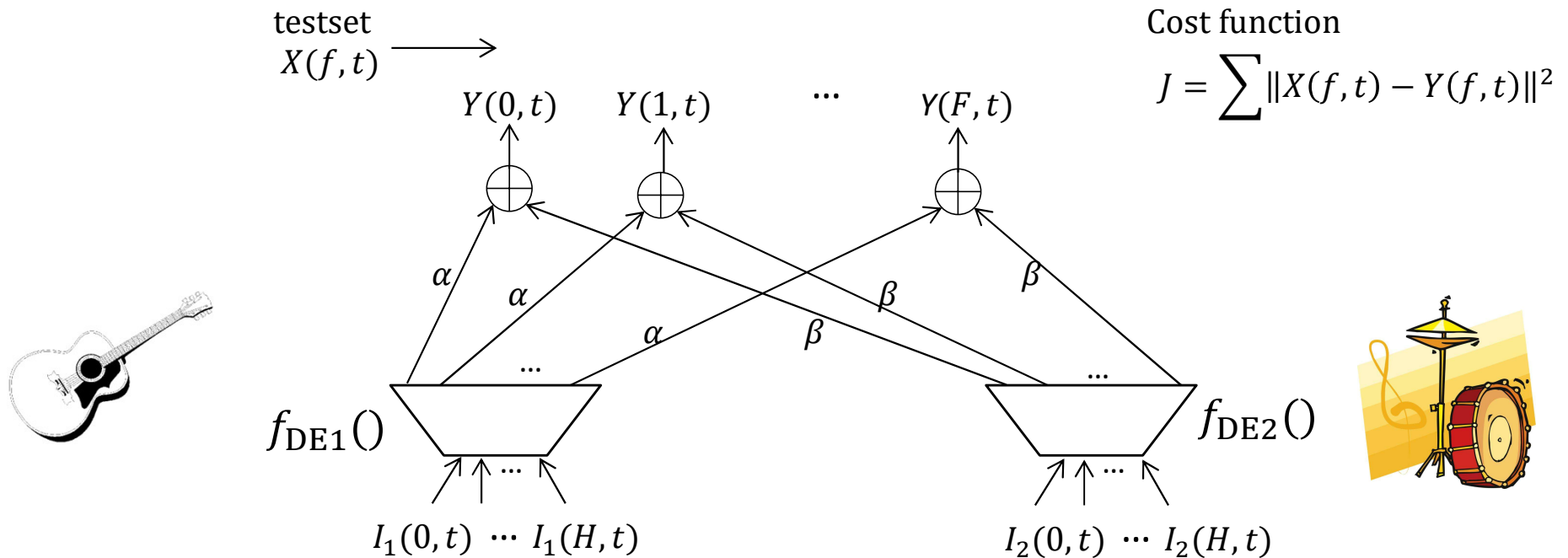

Estimate $I_1()$ and $I_2()$ to minimize cost function $J()$

- The sum of the outputs of both neural dictionaries
 - For some unknown input

Separation

Test Process

testset
 $X(f, t)$

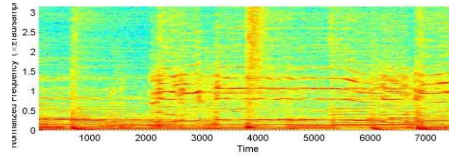

Cost function

$$J = \sum \|X(f, t) - Y(f, t)\|^2$$

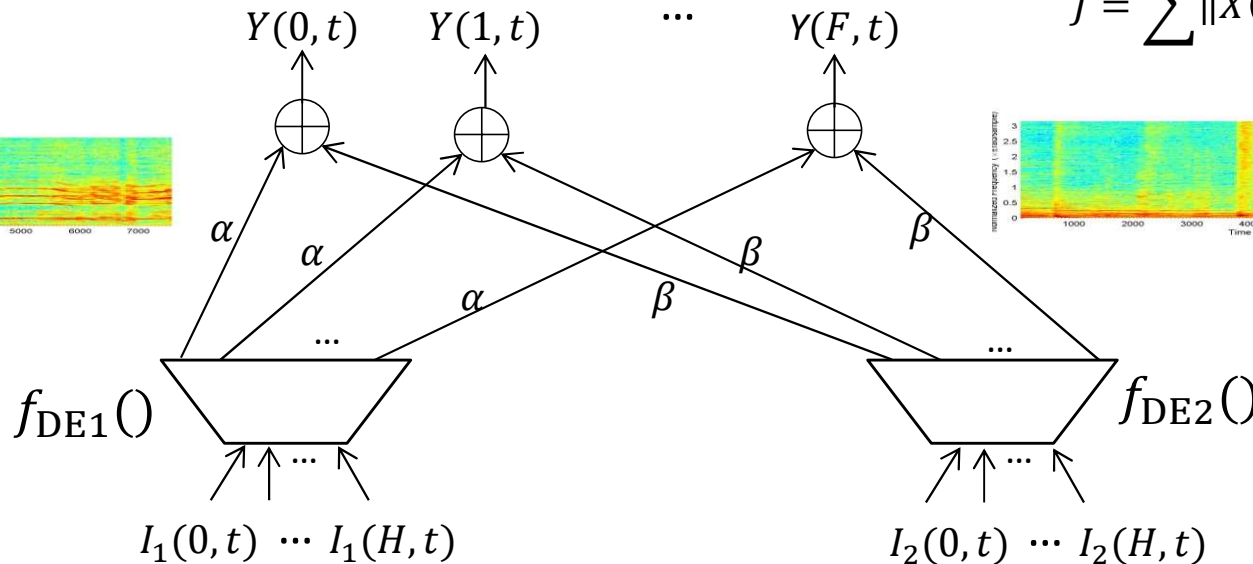
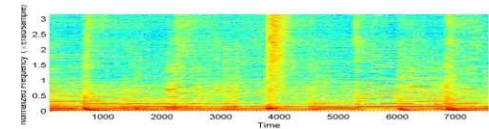
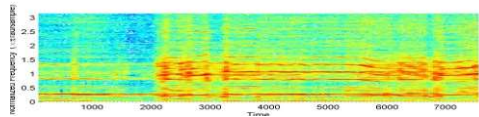

H : Hidden layer size

Estimate $I_1()$ and $I_2()$ to minimize cost function $J()$

- Given mixed signal and source dictionaries, find excitation that best recreates mixed signal
 - Simple backpropagation
- Intermediate results are separated signals

Example Results

Mixture



Separated



Original

Separated



Original

5-layer dictionary, 600 units wide

- Separating music

Story for the day

- Classification networks learn to predict the *a posteriori* probabilities of classes
 - The network until the final layer is a feature extractor that converts the input data to be (almost) linearly separable
 - The final layer is a classifier/predictor that operates on linearly separable data
- Neural networks can be used to perform linear or non-linear PCA
 - “Autoencoders”
 - Can also be used to compose constructive dictionaries for data
 - Which, in turn can be used to model data distributions